



Form 1 – Application for Approval of Development

Swan and Canning Rivers Management Act 2006 – Part 5 – section 72(1)

1. Applicant details

The applicant is the person with whom the department, on behalf of the Chief Executive Officer, will correspond, unless an authorised agent has been appointed to act on behalf of the applicant, in which case correspondence will be sent direct to the agent.

Name	George Hajigabriel		
Position (if applicable)	Director		
Organisation (if applicable)	Rowe Group		
Contact person	George Hajigabriel		
Postal address	Level 3, 369 Newcastle Street		
Town/Suburb	Northbridge	State	WA
		Postcode	6003
Telephone	Work (08) 9221 1991	Mobile	0412 498 503
Email	george.hajigabriel@rowegroup.com.au		

I give authority for an agent (as identified at item No. 3) to act on my behalf during the assessment of the application YES NO

If 'YES', please provide Agent's details at item No. 3

Applicant signature		Date	
---------------------	--	------	--

2. Landowner details

All owner(s) of the land must sign this application. Where land is owned by the Crown or has a management order granted to a local government or other agency, this application must be signed by the relevant landowner or management body as required under section 72(5)(a) of the Act. If there are more than two landowners, please provide the additional information and signature(s) on a separate page.

Details of first landowner

Name	State of WA (refer to attached letter of consent)		
Position (if applicable)			
Organisation (if applicable)	Department of Planning Lands and Heritage		
Contact person	Conor Noone (A/Project Officer Land Management Metropolitan & Peel)		
Postal address			
Town/Suburb		State	
		Postcode	

I consent to this application being made.

First landowner signature	refer to attached letter of consent	Date	
---------------------------	-------------------------------------	------	--

Details of second landowner (if applicable)

Name			
Position (if applicable)			
Organisation (if applicable)			
Contact person			
Postal address			
Town/Suburb		State	
		Postcode	

I consent to this application being made.

Second landowner signature		Date	
----------------------------	--	------	--



3. Authorised agent details (if applicable)

The applicant must sign the form and tick the authorisation under item No. 1 to provide authority for an appointed authorised agent to act on their behalf.

Details of authorised agent

Name	N/A		
Position (if applicable)			
Company/agency (if applicable)			
ACN/ABN (if applicable)			
Postal address			
Town/Suburb		State	Postcode
Telephone	Work	Mobile	
Email			
Authorised Agent signature		Date	

4. Location of proposed development

Certificate of title information	Volume	LR3000	Folio	431
	Diagram/plan/deposit plan no.	35070		
Lot No.(s)	8378			
Location				
Reserve No.(s) (if applicable)	24959			
Street No.(s) and name	Jutland Parade			
Town/Suburb	Dalkeith			
Nearest road intersection	Adlema Place			

5. Details of proposed development

Please provide a written description of the proposed development (refer to the Development Application Guidelines for further details on what information to include in this section).

Estimated cost of development	Stairway - less than \$50,000
Current use of land	Stairway
Proposed development	Foreshore works, including stairway access (refer to attached letter and Design Report prepared by Josh Byrne and Associates).

Checklist

Information to include in your Part 5 development application

<input checked="" type="checkbox"/> Completed application form, including written consent of the landowner(s). (DBCA will organise landowner consent for the River reserve)
<input checked="" type="checkbox"/> Additional information including details of the proposed development (including the existing and proposed use of the site and proposed hours of operation) and addressing any relevant issues identified in the policies.
<input checked="" type="checkbox"/> Plans and specifications of the proposed development showing: <ul style="list-style-type: none"><input checked="" type="checkbox"/> current and proposed levels (contours at no greater than 1 metre intervals), including retaining structures and fill requirements<input checked="" type="checkbox"/> the location, metric dimensions, materials, finishes and type of all existing and proposed structures, including services<input checked="" type="checkbox"/> sections through the site<input checked="" type="checkbox"/> the nature and extent of any open space and landscaping proposed<input checked="" type="checkbox"/> proposed external lighting and signage<input checked="" type="checkbox"/> any watercourse flowing through the site<input checked="" type="checkbox"/> position of any large trees or on-site vegetation, clearly marking vegetation to be retained and removed<input checked="" type="checkbox"/> the existing and proposed means of access and movement for pedestrians and vehicles
<input checked="" type="checkbox"/> Plans, elevations and sections of any building or structure proposed to be erected or altered and/or any building or structure to be retained.
<input checked="" type="checkbox"/> Site plan of the lot showing the development location in relation to: <ul style="list-style-type: none"><input checked="" type="checkbox"/> adjacent roads<input checked="" type="checkbox"/> rivers, creeks, springs and wetlands<input checked="" type="checkbox"/> nearby conservation areas and/or Bush Forever sites<input checked="" type="checkbox"/> floodway and floodplain boundaries<input checked="" type="checkbox"/> land reserved for Parks and Recreation under the Metropolitan Region Scheme
<input checked="" type="checkbox"/> Information on the availability of drainage and sewer.

<input checked="" type="checkbox"/> A Information on any impacts to heritage sites or protected areas and subsequent approvals (if required).
<input checked="" type="checkbox"/> A Information regarding potential acid sulfate soils and/or contamination.
<input checked="" type="checkbox"/> A If the proposed development is likely to disturb potential and/or actual acid sulfate soils or a contaminated site, a preliminary investigation is required, and the results included with this application.
<input checked="" type="checkbox"/> Details of the proposed construction methodologies.
<input checked="" type="checkbox"/> Geotechnical information.
<input checked="" type="checkbox"/> A Operational details (where relevant) e.g. for a proposed café.
<p>Larger developments should also include:</p> <ul style="list-style-type: none"> <input checked="" type="checkbox"/> photo montages showing the development in relation to the river and foreshore landscape <input checked="" type="checkbox"/> A information on the impacts of parking, noise and traffic generated by the proposal <input checked="" type="checkbox"/> details of stormwater management incorporating water sensitive urban design principles <input checked="" type="checkbox"/> A details of any dewatering proposed during construction including the expected volumes, water quality, method of disposal and sampling regimes in accordance with DBCA's Policy 50 – Planning for dewatering affecting the Swan and Canning Development Control Area <input checked="" type="checkbox"/> any specialist studies and/or management plans required to support the application such as traffic, heritage, environmental, engineering, landscaping or urban design studies.

If insufficient information is provided with the initial application, further information will be sought from the applicant. If the required information is not provided, the application will be returned. DBCA cannot process the application without the completed (and correct) application form.



MRS

Form 1 Application for Planning Approval

Owner/s details

Registered proprietor/s (landowner/s) or the authorised agent's details **must** be provided in this section. If there are more than two landowners please provide all relevant information on a separate page. Signature/s must be provided by all registered proprietors or by an authorised agent.

Alternatively, a letter of consent, which is signed by all registered proprietors or by the authorised agent, can be provided.

Full name State of Western Australia

Company/agency (if applicable)

ACN/ABN (if applicable)

Postal address

Town/suburb Postcode

The landowner/s or authorised agent consents to the applicant submitting this application

Signature Date
Refer to attached letter of consent

Print name and position
(if signing on behalf of a company or agency)

Applicant details

Name/company Rowe Group

Contact person George Hajigabriel

Postal address Level 3, 369 Newcastle Street

Town/suburb Northbridge WA Postcode 6003

Phone (08) 9221 1991 Email george.hajigabriel@rowegroup.com.au

Applicant signature 

Print name and position Date 21-3-2024
(if signing on behalf of a company or agency)
George Hajigabriel - Director

Property details

Certificate of title description of land:	Lot No	8378	Location No
Plan or diagram 35070	Vol		Folio

Certificate of title description of land:	Lot No		Location No
Plan or diagram	Vol		Folio

Title encumbrances (e.g. easements, restrictive covenants)	Management Order to the City of Nedlands
Locality of development (house no., street name, suburb, etc)	Jutland Parade, Dalkeith
Nearest street intersection	Adlema Place
Existing building/land use	Contains stairway access
Description of proposed development and/or use	Foreshore works
Nature of any existing buildings and/or use	Stairway providing foreshore access
Approximate cost of proposed development (excl. gst) \$	Stairway - less than \$50,000
Estimated time of completion	48 months post approval

Office use only

Acceptance officer's initials <input style="width: 100px; height: 20px;" type="text"/>	Date received <input style="width: 100px; height: 20px;" type="text"/>
Local government reference No. <input style="width: 100px; height: 20px;" type="text"/>	Commission reference No. <input style="width: 100px; height: 20px;" type="text"/>

The information and plans provided with this application may be made available by the WAPC for public viewing in connection with the application.

Additional Information to be provided on the MRS Form 1

- Is the development within a designated Bushfire Prone Area? Yes No
- If 'yes', have bushfire hazard issues been identified and addressed (e.g. by providing a BAL Assessment(s) or BAL Contour Map and a Bushfire Management Plan with the application)? Yes No
 N/A
- If NA is selected and the development is in a designated bushfire prone area then a short statement justifying why SPP 3.7 does not apply should be included.
- Does your application require determination by a Development Assessment Panel? (DAP) Yes No
- Please refer to the following website for DAP requirements: www.dplh.wa.gov.au/daps
- If yes, please complete DAP Application Form as per DAP requirements.

Checklist (supporting information)

Please complete the checklist below and ensure that all the relevant information is provided with the application.

1. Completed Metropolitan Region Scheme (MRS) Form 1
2. Plans at a scale not less than 1:500 (A3) showing:-
 - (i) the location of the site including street names, lot number(s), north point and the dimensions of the site;
 - (ii) the existing and proposed ground and floor levels over the whole of the land that is the subject of the application, including details of proposed cut and fill, and retaining walls;
 - (iii) the location, metric dimensions, materials, finishes and type of all existing and proposed structures, including services, on the land that is the subject of the application and all existing structures and vegetation proposed to be removed;
 - (iv) the existing and proposed use of the site, including proposed hours of operation and buildings to be erected on the site;
 - (v) the existing and proposed means of access and egress for pedestrians and vehicles to and from the site;
 - (vi) the location, number, dimensions and layout of all car parking spaces intended to be provided, including provision for the disabled;
 - (vii) the location and dimensions of any area proposed to be provided for the loading and unloading of vehicles carrying goods or commodities to and from the site and the means of access to and from those areas;
 - (viii) the location, dimensions and design of any open storage or trade display area and particulars of the manner in which it is proposed to develop those areas;
 - (ix) the nature and extent of any open space and landscaping proposed for the site; and
 - (x) proposed external lighting and signage.
3. Plans, elevations and sections, as appropriate, of any building or structure proposed to be erected or altered and of any building or structure it is intended to retain;
4. Any specialist studies that the responsible authority may require the applicant to undertake in support of the application such as traffic, heritage, environmental, engineering or urban design studies;
5. Any management plans the responsible authority may require to support or implement the application; and
6. Any other plan or information that the responsible authority may require to enable the application to be determined. This may include scale models or information in digital formats.

For additional information please refer to Development Control Policy 1.2
www.dplh.wa.gov.au/getmedia/37533b97-e0ad-4947-9d00-c4d62fa92746/DCP_1-2_general_principles

Development application checklist - lodgement requirements

<p>Application signatures</p>	<p>The MRS Form is to be signed by the registered proprietor/s as shown on the certificate/s of title.</p> <p>Where the landowner/s cannot sign, an authorised agent can sign and attach evidence of the authority.</p> <p>If the subject land is owned by a company, you must confirm whether it is a sole proprietorship company and state the full name/s and position/s of the company signatory/ies.</p> <p>Appropriate company signatory/ies include one director and the company seal, two directors, or one director and one secretary.</p> <p>Eg: _____</p> <p style="text-align: center;">John F. Smith - Director Peter S James - Director Smith Pty Ltd Smith Pty Ltd</p> <p>Or _____</p> <p style="text-align: center;">John F. Smith - Sole Director Smith Pty Ltd</p> <p>If the subject land is owned by a strata company, consent can be signed by the strata company secretary or by an elected person of the strata company providing proof of authority either by letter of delegated authority, signed by all strata owners or minutes showing delegated authority.</p>
<p>Certificate of Title</p>	<p>Ensure the Certificate of Title/s is/are current (within 6 months) and provide copy/s.</p>
<p>Change of name</p>	<p>Applications made by either private owners or companies who have changed names to that depicted on the Certificate of Title, must provide supporting documentation showing the change of name such as:</p> <ul style="list-style-type: none"> • a transfer of land document that incorporates a lodgement receipt, • a company search from the Australian Securities and Investment Commission, • a marriage certificate or • a change of name certificate.
<p>Contacts</p>	<p>A contact name, phone and email address is essential, in the event more information is required and for issuing correspondence relating to the Department's decision.</p>
<p>Contracts of sale</p>	<p>Where the land is subject to a contract of sale or offer and acceptance, evidence of landowner's consent must be provided. Relevant evidence may include;</p> <ul style="list-style-type: none"> • an express provision of consent by the vendor on the contract of sale or offer and acceptance, • a letter of consent from the registered proprietor/s giving prospective purchaser/s consent to lodge the application or • a copy of the transfer of land document that incorporates a lodgement receipt.
<p>Crown land</p>	<p>Where the land is registered in the name of the Crown, the application form must be signed by an authorised officer of the Department of Lands, stating the name and position. Alternatively, a letter of consent from the authorised Crown land officer.</p>
<p>Deceased estates</p>	<p>Where the land is registered in joint tenants, a copy of the death certificate of the deceased landowner must be provided. Where the land is registered in tenants in common, a copy of the grant of probate or endorsed enduring power of attorney must be provided.</p>
<p>Designated Bushfire Prone Area</p>	<p>If the proposed development is located within a Bushfire Prone Area according to the Map of Bush Fire Prone Areas, then bushfire hazard issues should be identified and addressed (e.g. by providing a BAL assessment(s) or BAL Contour Map and a Bushfire Management Plan with the application). If NA is selected and the development is in a designated bushfire prone area then a short statement justifying why SPP 3.7 does not apply should be included.</p>
<p>Emailed documents</p>	<p>Emailed applications or documents are acceptable, however the application must be signed by the registered proprietor/s.</p>
<p>Government agencies</p>	<p>Where the land is registered in the name of a government authority, the application form must be signed by an authorised officer of the relevant authority, stating the name and position of the signatory/s. Alternatively, a letter of consent signed by an authorised officer.</p>



Department of Planning,
Lands and Heritage

GOVERNMENT OF
WESTERN AUSTRALIA

Our ref: Case: N/A; File: 03013-1957.
Enquiries: Conor Noone
Email: Conor.Noone@dplh.wa.gov.au
Phone: (08) 6552 4445

Rowe Group
Level 3 369 Newcastle Street
Northbridge WA 6003

Sent via email to: Ashleigh.Maple@rowegroup.com.au
Cc: George.Hajigabriel@rowegroup.com.au

Dear Ashleigh,

REQUEST FOR LANDOWNER CONSENT TO LODGE DEVELOPMENT APPLICATION IMPACTING STATE LAND – LOT 8378 ON DIAGRAM 35070 BEING RESERVE 24959 – CITY OF NEDLANDS

I refer to your email dated the 29th of February 2024 where you requested landowner consent to lodge an application for development approval which impacts land owned by the State of Western Australia. The impacted land is Lot 8378 on Diagram 35070, being part of Crown Reserve 24959 (the Land), which is managed by the City of Nedlands (City) for the purpose of "Recreation". The land is detailed in Attachment 1.

Given the reserve is under the full care, control and management of the City this is a matter for the City to consider. We write to grant consent, as landowner, to the lodgement and progression of the enclosed Application for Development Approval for foreshore works.

This letter of consent has been provided to facilitate only the processing of this application. No endorsement, undertaking or assessment is made or intended, and this should not be taken as approval to carrying out the proposed development or to any modification of the tenure of the State land.

This Department will not incur any of the application fees or associated costs with the preparation of plans or development in association with the foreshore works. The applicant will be responsible for all costs associated with the proposal.

The applicant is advised that this Letter of Consent has been signed subject to the following conditions:

1. The applicant preparing a foreshore management plan and obtaining any approvals or permits, as required from the Department of Biodiversity, Conservation and Attractions for any proposed development over the Land in accordance with the *Swan and Canning Rivers Management Act 2006*.
2. The applicant adhering to any requirements, conditions and/or maintenance agreement imposed by the City of Nedlands.

Please do not hesitate to contact Conor Noone, Acting Project Officer – Land Management Metropolitan & Peel at the Department of Planning, Lands and Heritage on (08) 6552 4445 or at Conor.Noone@dplh.wa.gov.au should you require further information.

Yours sincerely



Zoe James
A/Assistant Manager
Land Use Management – Metropolitan and Peel
Department of Planning, Lands and Heritage

21 March 2024

Attachment 1

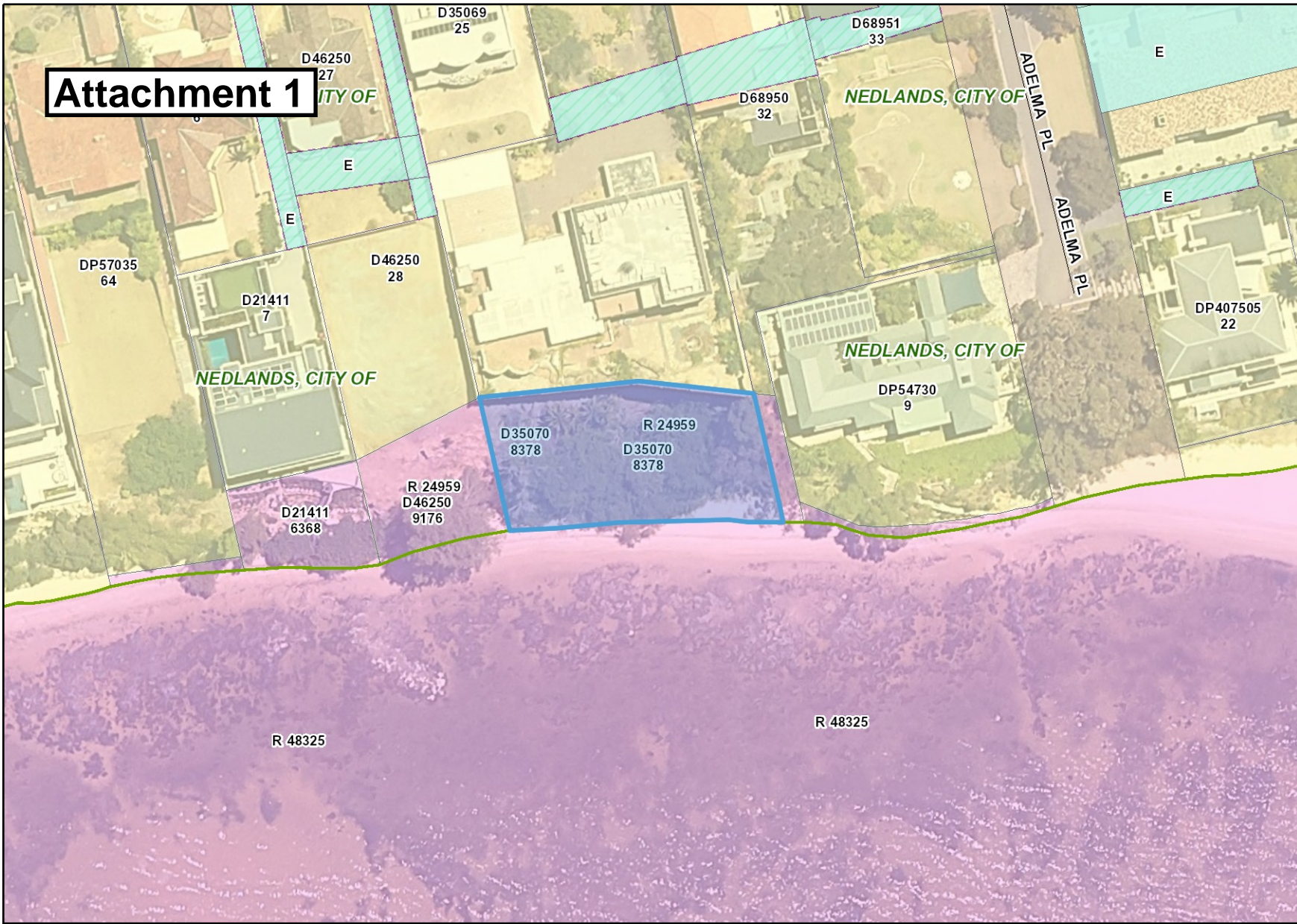

- ### Legend
- Local Government Area
 - Cadastre (View 1)
 - Easements and Other Interests
- #### Roads
- Minor
- #### Land Tenure Large Scale ALL
- Easements
 - Other Interests
 - Crown Lease
 - Crown Reserve
 - State Forest; Timber Reserve
 - Marine Park
 - Water Isolation
 - Public Road
 - Unallocated Crown Land; Closed Road
 - Miscellaneous (Type 3)
 - Crown Allotment (Type 2)
 - Building, Survey Strata Lots
 - Lot on Survey (Type 1)
- #### Land Tenure Large Scale 16K
- Easements
 - Other Interests
 - Crown Lease
 - Crown Reserve

Notes:

- * The data that appears on the map may be out of date, not intended to be used at the scale displayed, or subject to license agreements. The map should only be used in matters related to Department of Planning, Lands and Heritage business.
- * This map is not intended for measurement purposes.

Map was produced using DPLH's InQuery.

Lot 8378 on Diagram 35070, being Reserve 24959 (outlined blue)

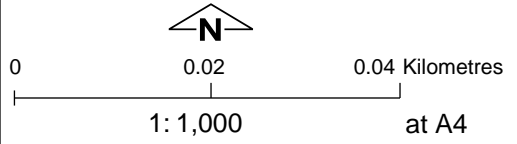

Job Ref: 9824
26 March 2024

Chief Executive Officer
City of Nedlands
PO Box 9
NEDLANDS WA 6909

Attention: Ms Aviva Micevski – Coordinator Statutory Planning

Dear Aviva,

**APPLICATION FOR DEVELOPMENT APPROVAL – LOT 8378 JUTLAND PARADE
DALKEITH – FORESHORE WORKS**

Rowe Group acts on behalf of Mr and Mrs Fry being the landowners of No.26 (Lot 24) Jutland Parade Dalkeith. We have been instructed by our Client to prepare an lodge an application for Development Approval for works in the foreshore reserve which is directly adjacent to their land. The works are proposed to be located on Lot 8378 Jutland Parade Dalkeith, being Reserve 24959 (the 'subject site'), on land owned by the State of Western Australia and located within the Development Control Area identified by the *Swan and Canning Rivers Management Act 2006 ('SCRM Act')*.

To enable this Application to be processed, the following documentation is enclosed:

- ▲ Completed and signed Metropolitan Region Scheme ('MRS') Form 1;
- ▲ Copy of the Landowner Consent provided by an authorised officer of the Department of Planning Lands and Heritage (DPLH);
- ▲ Copy of the current Certificate of Title; and
- ▲ Design Report prepared by Josh Byrne and Associates (includes Development Plans and several Appendices).

The subject site is contained within the 'Parks and Recreation' reservation of the Metropolitan Region Scheme (MRS). As such, the development application is to be determined by the Western Australian Planning Commission (WAPC), on advice from the City of Nedlands and the Department of Biodiversity, Conservation and Attractions. Under the provisions of Clause 29 of the MRS, the Local Authority is to forward a copy of the application to the WAPC within seven (7) days of receipt of the application. The Local Authority may then



Level 3
369 Newcastle Street
Northbridge 6003
Western Australia

p: 08 9221 1991
f: 08 9221 1919
info@rowegroup.com.au
rowegroup.com.au



provide recommendations to the WAPC in respect of the application within forty-two (42) days of receipt of the application. Please note that a development application fee is not required for this application given the subject land is reserved under the Metropolitan Region Scheme (MRS).

LOCATION AND SITE DESCRIPTION

The subject site is located within the City of Nedlands in the suburb of Dalkeith. The subject site has an area of 893m² and is located abutting the Swan River adjacent to No.26 (Lot 24) Jutland Parade Dalkeith. The site currently contains a brick staircase providing access to the Swan River however the staircase is currently unsafe and in a state of disrepair. The foreshore area is currently overgrown with Pepper Trees, weeds and grasses. The site comprises Reserve 24959, more fully described as Lot 8378 on Diagram 35070.

The City of Nedlands issued approval on the 30 January 2024 for a single house on No.26 (Lot 24) Jutland Parade, Dalkeith (DA23/88242). Although the works in the foreshore area which form part of this application did not form part of the application for No.26 (Lot 24) Jutland Parade, Dalkeith, the works and the intent to submit a separate formal application for them, was foreshadowed to the City during the course of assessment of the single house application.

Refer to **Attachment 1 – Certificate of Title**.

PROPOSED DEVELOPMENT

This Application seeks approval to undertake works within the foreshore area to provide access from No.26 (Lot 24) Jutland Parade, Dalkeith to the water level of the Swan River. The proposed development incorporates the following:

- ▲ A new replacement staircase providing direct access from No.26 (Lot 24) Jutland Parade, Dalkeith to the river foreshore, including:
 - Installation of a Bondek landing built to the northern boundary of the reserve to connect to a pedestrian access point from No.26 (Lot 24) Jutland Parade;
 - Installation of a 'Light Touch' aluminium walkway structure, including a Surefoot piling system, aluminium floor grate platforms, stairs to negotiate level changes and balustrading;
 - Installation of a Terraforce retaining wall part way down the slope to accommodate the level change of the stairs and structural integrity of the structure;
 - Installation of limestone rock revetment to the back of the shoreline, to protect against erosion in high tides and storm surge events;
- ▲ Site clearing and weed management, surface preparation and erosion control measures;
- ▲ Revegetation planting including planting of endemic species, monitoring and maintenance of the foreshore area by the owners of No.26 (Lot 24) Jutland Parade, Dalkeith.

Development Plans are contained within the Design Report prepared in support of the proposal, by Josh Byrne and Associates. Refer to **Attachment 2 – Foreshore Design Report**.

TOWN PLANNING CONSIDERATIONS

The subject site is reserved under the Metropolitan Region Scheme ('MRS') for the purposes of 'Parks and Recreation'. Refer to **Figure 1 - Metropolitan Region Scheme**.

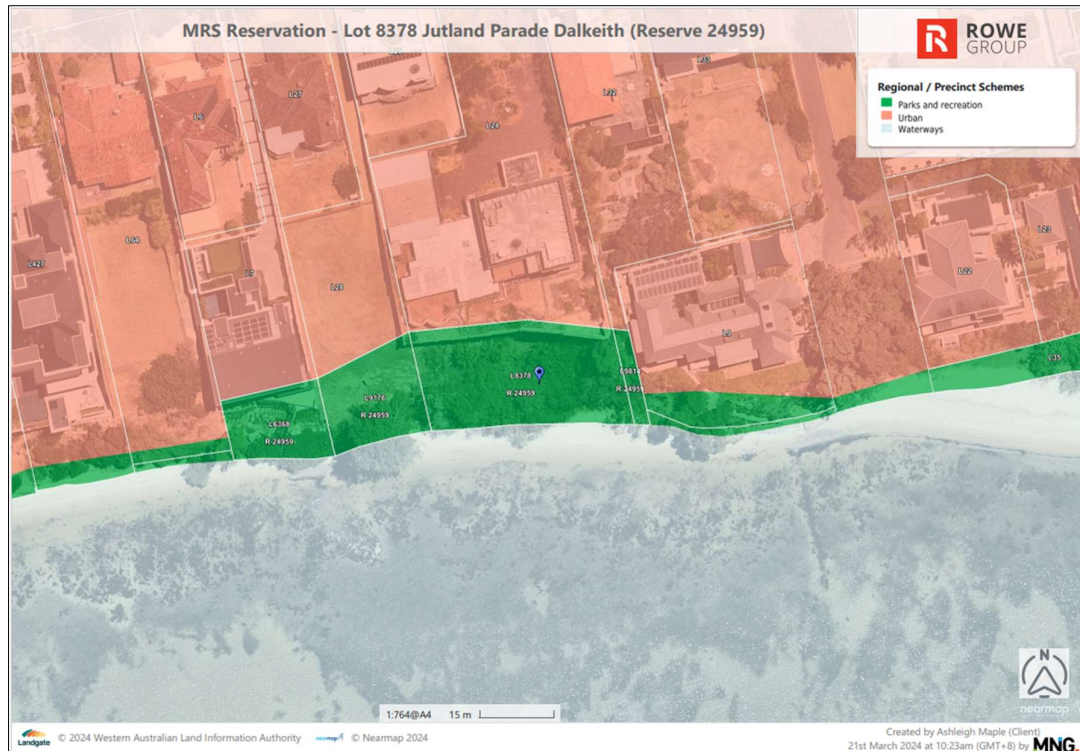

Figure 1 – Metropolitan Region Scheme

In accordance with Clause 28 and 29(1)(a)(i) and (ii) of the MRS, the Application is required to be referred to the Western Australian Planning Commission ('WAPC') for determination, following a recommendation being provided by the City of Nedlands.

The subject site is also located within the Swan River Trust Development Control Area identified by the *SCRM Act* and therefore referral to the Department of Biodiversity, Conservation and Attractions is required as part of the application process.

OTHER CONSIDERATIONS

In preparing the design for the foreshore access, consideration has been given to slope stabilisation, erosion control, revegetation, monitoring and maintenance of the site, structural integrity, coastal risk, tide and water



levels. The Foreshore Design Report prepared by Josh Byrne & Associates includes the following relevant technical reports prepared to inform the design process:

- ▲ Survey – prepared by MNG
- ▲ Geotechnical Report – prepared by Galt Geotechnics
- ▲ Revegetation Management Plan – prepared by Tranen Revegetation Systems
- ▲ Technical Note on Dynamics and Design Considerations – Prepared by Seashore Engineering

Refer **Attachment 2 - Foreshore Design Report.**

State Planning Policy 3.7 – Planning in Bushfire Prone Areas

The subject site is not identified as being bushfire prone by the Department of Fire and Emergency Services Map of Bushfire Prone Areas and as such, no further action is required in this regard.

Draft State Planning Policy 2.9 – Planning for Water

Draft State Planning Policy 2.9 – Planning for Water ('Draft SPP 2.9') seeks to ensure that planning and development considers water resource management and includes appropriate water management measures to achieve optimal water resource outcomes. The proposed development responds to section 7.1 and 7.7 of Draft SPP 2.9 which includes various general policy measures and specific policy measures for the Swan Canning River system, as follows:

- ▲ The proposed development includes the removal of existing weed species present on the reserve and the planting of endemic species to increase vegetation coverage and stabilise the slope;
- ▲ Provides sufficient separation between the structure and the 1:10 year flood level;
- ▲ Replaces a dilapidated, unsafe structure with an improved outcome for the site, maintaining and improving access to the River that would otherwise be inaccessible;
- ▲ The proposed development is compatible with its riverine environment and provides access to the foreshore for the adjacent land;
- ▲ The proposal enhances the natural landscape character through the design of the stairway and revegetation works which will remove an invasive weed and replace it with natural vegetation.

CONCLUSION

The Application seeks approval for a new access to the river foreshore to replace the existing stairway access. The proposed development is considered consistent with the State and Local planning framework for the following reasons:

- ▲ The proposed development improves the existing, dilapidated walkway and stairway access, removes existing weed species and unmanaged landscaping;
- ▲ The proposed development would improve activation and amenity of the immediate area and provide a useable space for the occupiers of No.26 (Lot 24) Jutland Parade, Dalkeith; and



- ▲ The proposed development provides an opportunity to improve the reserve through removal of non-native plant and invasive weed species, planting of endemic species to regenerate and enhance the ecological environment while improving stability for the metastable slope.

On the basis of the above and attached, we respectfully request the WAPC support the proposed development and that the Development Approval is granted.

Should you require any further information or clarification in relation to this matter, please contact George Hajigabriel on 9221 1991.

Yours faithfully,

George Hajigabriel

Rowe Group

Encl. Certificate of Title
Foreshore Design Report

Cc. Client
Josh Byrne and Associates

WESTERN



AUSTRALIA

TITLE NUMBER

Volume Folio

LR3000 431

RECORD OF QUALIFIED CERTIFICATE
OF
CROWN LAND TITLE
UNDER THE TRANSFER OF LAND ACT 1893
AND THE LAND ADMINISTRATION ACT 1997

The undermentioned land is Crown land in the name of the STATE OF WESTERN AUSTRALIA, subject to the interests and Status Orders shown in the first schedule which are in turn subject to the limitations, interests, encumbrances and notifications shown in the second schedule.

BGRoberts
REGISTRAR OF TITLES



LAND DESCRIPTION:

LOT 8378 ON DIAGRAM 35070

**STATUS ORDER AND PRIMARY INTEREST HOLDER:
(FIRST SCHEDULE)**

STATUS ORDER/INTEREST: RESERVE UNDER MANAGEMENT ORDER

PRIMARY INTEREST HOLDER: CITY OF NEDLANDS

**LIMITATIONS, INTERESTS, ENCUMBRANCES AND NOTIFICATIONS:
(SECOND SCHEDULE)**

1. RESERVE 24959 FOR THE PURPOSE OF RECREATION
MANAGEMENT ORDER. CONTAINS CONDITIONS TO BE OBSERVED.

- Warning: (1) A current search of the sketch of the land should be obtained where detail of position, dimensions or area of the lot is required.
Lot as described in the land description may be a lot or location.
(2) The land and interests etc. shown hereon may be affected by interests etc. that can be, but are not, shown on the register.
(3) The interests etc. shown hereon may have a different priority than shown.

-----END OF CERTIFICATE OF CROWN LAND TITLE-----

STATEMENTS:

The statements set out below are not intended to be nor should they be relied on as substitutes for inspection of the land and the relevant documents or for local government, legal, surveying or other professional advice.

SKETCH OF LAND: D35070
PREVIOUS TITLE: LR3000-431
PROPERTY STREET ADDRESS: LOT 8378 JUTLAND PDE, DALKEITH.
LOCAL GOVERNMENT AUTHORITY: CITY OF NEDLANDS
RESPONSIBLE AGENCY: DEPARTMENT OF PLANNING, LANDS AND HERITAGE (SLSD)

NOTE 1: K630802 CORRESPONDENCE FILE 03013-1957-01RO



26 JUTLAND PARADE, DALKEITH
FORESHORE DESIGN

01 CONTENTS

- 03 BACKGROUND RESEARCH
- 04 SITE CONTEXT AND CHARACTER
- 05 SITE CONDITIONS
- 06 DESIGN RESPONSE
 - 07 GENERAL ARRANGEMENT
 - 08 GENERAL ARRANGEMENT - WALKWAY STRUCTURE AXONOMETRIC
 - 09 WALKWAY STRUCTURE AND CONSTRUCTION METHODOLOGY
 - 10 CLEARING, SLOPE STABILISATION & EROSION CONTROL STRATEGY
 - 11 REVEGETATION, MONITORING & MAINTENANCE STRATEGY
 - 12 PLANTING PALETTE
 - 13 TYPICAL PLANTING DETAILS
- 14 WALKWAY LAYOUT
- 15 ELEVATION
- 16 SECTIONS

APPENDICES

MNG. SURVEY

GALT GEOTECHNICS REPORT

TERPKOS STRUCTURAL ENGINEERS DOCUMENTATION

TRANEN REVEGETATION MANAGEMENT PLAN

TRANEN PLANTING INITIAL SPECIES LIST

SEASHORE - TECHNICAL NOTE: 26 JUTLAND PARADE WALLING
DYNAMICS AND DESIGN CONSIDERATIONS

Document Status

Date of issue	Rev No.	Reason for Issue	Author	Reviewed By	Approved by
29/02/2024	A	Issue to Client	PV/NK/MC	PV/MC	PV
08/03/2024	B	Issue to Client	PV/NK/MC	NK	PV

This document may only be used for the purpose for which it was commissioned in accordance with the Terms of Engagement.

This document is intended to be printed at A3.

02 INTRODUCTION

The owners of 26 Jutland Parade Dalkeith have appointed Josh Byrne & Associates (JBA) to develop a design for the setback area designated in the Development Control Area (DCA).

This response will accompany the Development Application for the lot.

03 BACKGROUND RESEARCH

JBA has conducted site analysis and reviewed relevant reports and policy guidance documents.

Key documents reviewed include:-

- Swan and Canning Rivers Foreshore Assessment and Management Strategy (Swan River Trust, March 2008)
- Swan Canning River Protection Strategy (Department of Parks and Wildlife, September 2015)
- Swan Canning River System Development Control Procedures (Swan River Trust, 2020)
- Swan River System Landscape Description (Swan River Trust, 1997)
- Corporate Policy Statement 48 - Planning for Development Setback Requirements (Department of Parks and Wildlife, June 2016)
- Point-Resolution-Management-Plan (City of Nedlands, March 2014)
- Potential Impacts of Climate Change on the Swan and Canning Rivers: Summary Paper (Swan River Trust)
- Best Management Practices for Foreshore Stabilisation - Approaches and Decision Support Framework (Swan River Trust, December 2009)
- Best Management Practices for Foreshore Stabilisation - Direct Shore Stabilisation Approaches (Swan River Trust, December 2009)

- Best Management Practices for Foreshore Stabilisation - Erosion Control Matting (Swan River Trust, December 2009)
- Swan River System Landscape Description Precinct 4 (Department of Parks and Wildlife)
- Soils and Landforms of the Perth Area (Department of Agriculture & Food)

Seashore has assessed the water levels on through analysis of Barrack Street tide gauge data set (1988-2021). Use of tidal planes is limited in the Swan River region. High water levels in the river occur almost exclusively within May-July and low water levels occurring from December-February. 1.65mCD (0.9m AHD) is typically reached about once per year.

Coastal Risk Australia indicate potential high tides increasing by another 0.84m by 2100. These factors need to be considered when designing the foreshore interface in this location.

The Foreshore Stabilisation, Approaches and Decision-Support Framework Report (Department Parks and Wildlife, December 2009) identifies a minimum direct hard treatment stabilisation approach for this foreshore area.

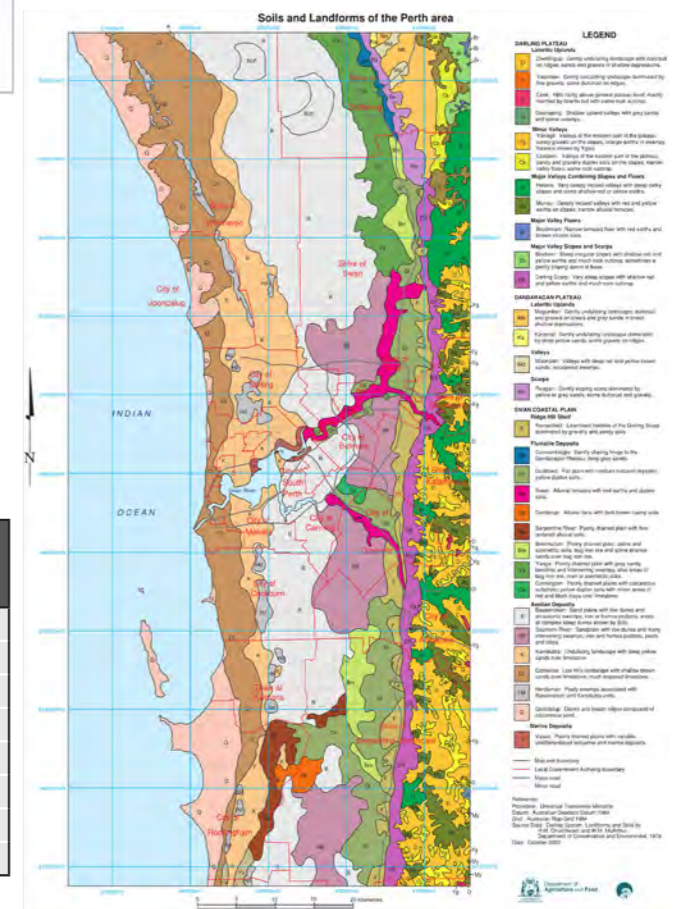
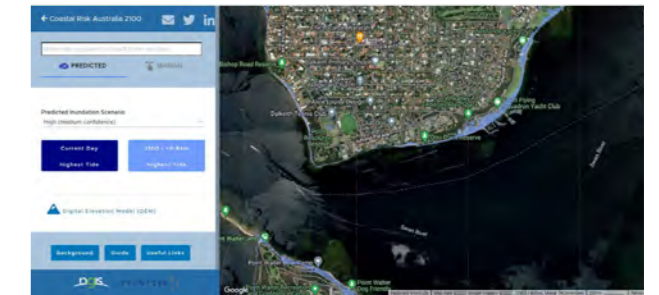
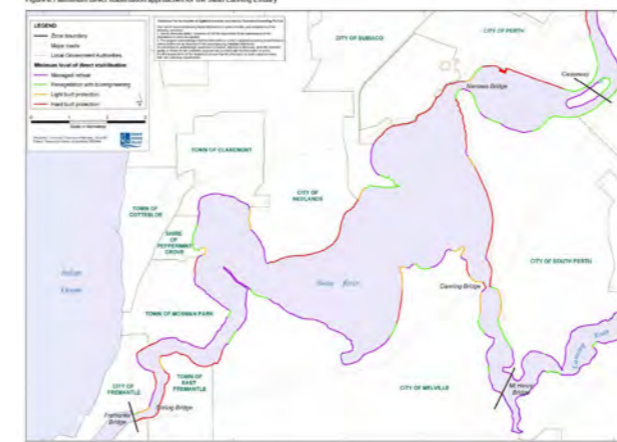
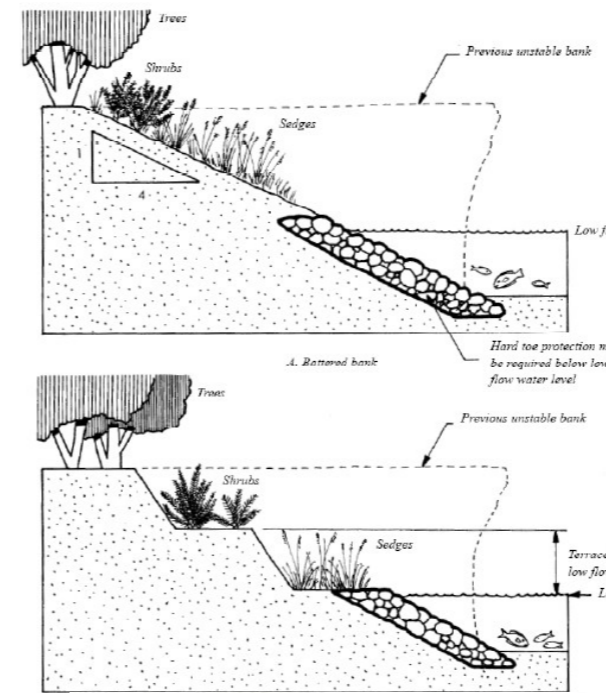

TIDAL PLANE	ABBREVIATION	LEVEL (MAHD)	LEVEL (MCD)
Est. 100-yr Recurrence Level	100yARI	1.2 mAHD	1.95 mCD
Est. 10-yr ARI	10yARI	1.1 mAHD	1.79 mCD
Est. 1-yr ARI	1yARI	0.9 mAHD	1.65 mCD
Highest Astronomical Tide	HAT	0.5 mAHD	1.29 mCD
Mean Higher High Water	MHHW	0.3 mAHD	1.03 mCD
Mean Sea Level	MSL	0.0 mAHD	0.75 mCD
Mean Lower Low Water	MLLW	-0.3 mAHD	0.46mCD
Lowest Astronomic Tide	LAT	-0.5 mAHD	0.30 mCD

Table: Barrack Street tide gauge data set (1988-2021)

04 SITE CONTEXT AND CHARACTER

The site is located between Otto Point reserve and Point Resolution Reserve on the Swan River foreshore at Dalkeith.

Geology series mapping contained in Fremantle Part Sheets 2033 I & 2033 IV, Perth Metropolitan Region, Environmental (Gozzard, 1983) indicates that the natural geology of the site comprises limestone. Visual observation also confirms indications of limestone outcropping in the setback area. The river interface of the adjacent lots also displays limestone outcroppings.

The site has very steep grades from the river edge at 0 AHD up to approximately 14.5 AHD. The northern edge of the setback is bordered by the client's house retaining wall, an impressive series of seven brick vaults approximately 8m high. The current path to the river is in a poor state. The brick path and stairs on the steep, sandy slope has been undermined and is unstable. Towards the river and to the western side of the existing brick stair are several limestone outcrops.



Img: Drone view looking north across the existing site

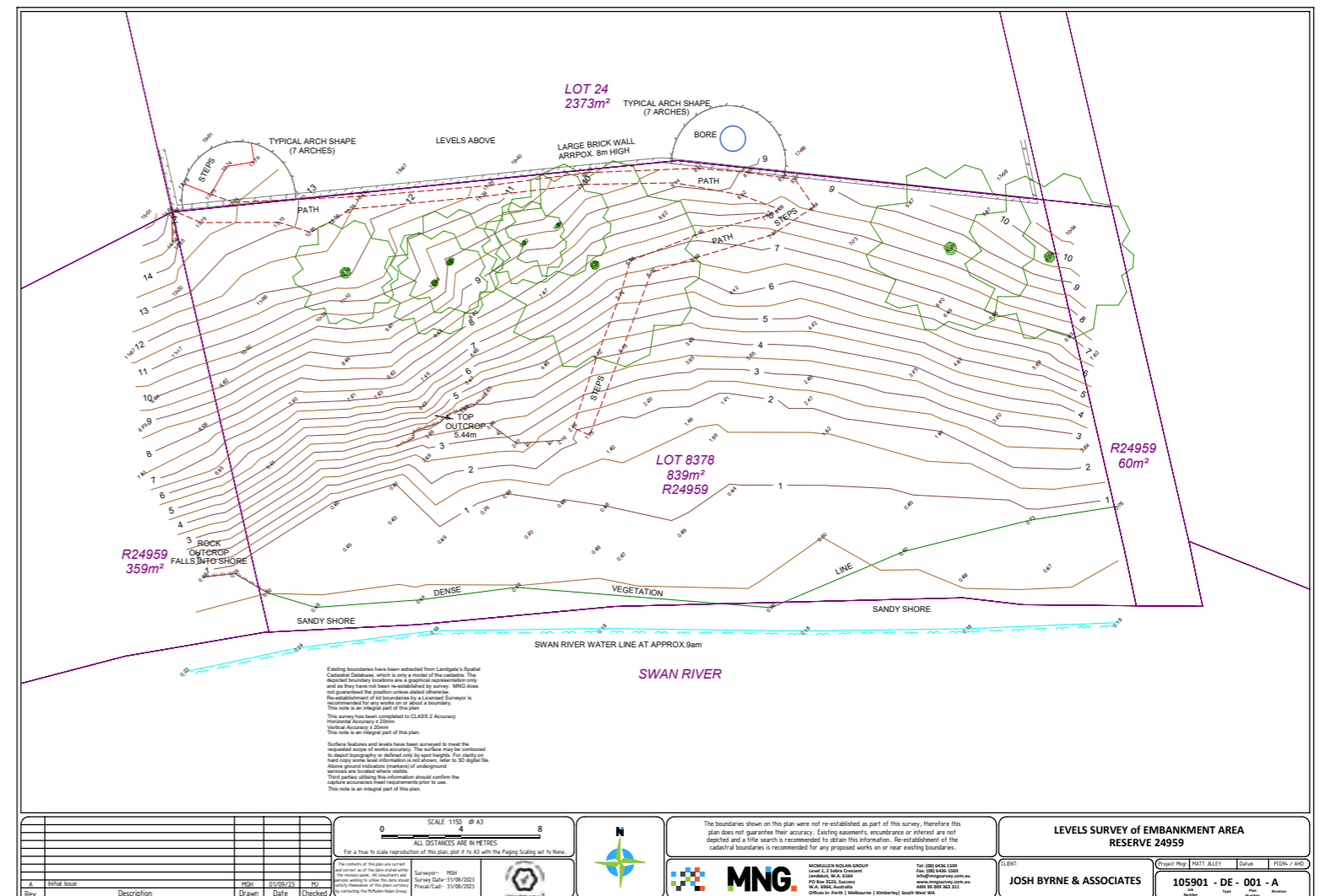

Fig Below: Pre Demolition Survey of setback. Provided by MNG.

05 SITE CONDITIONS



img: Nearmaps



Fig: Site from foreshore, overgrown with weeds



Fig: Limestone rock outcrop and invasive weeds



Fig: Bore and degraded walkway



Fig: Brick stair and walkway undermined



Fig: Undermined walkway and yellow sandy fill



Fig: Staircase entrance to site, graffitied



Fig: Remnants of irrigation, weeds and grasses



Fig: Rubbish, weeds and limestone outcrop

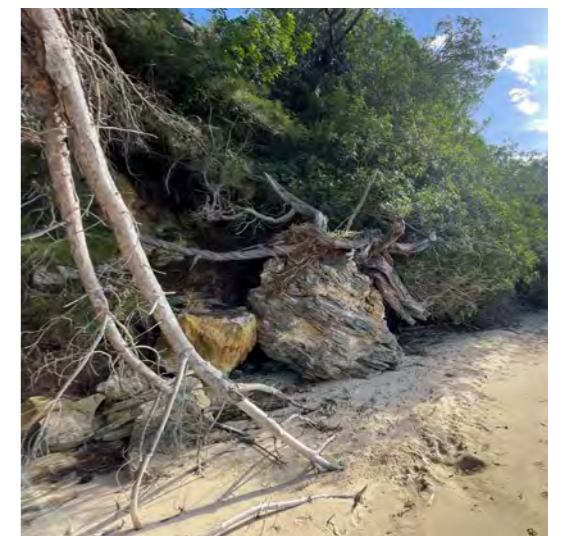

Fig: Limestone outcrop, site from foreshore

06 DESIGN RESPONSE

The design response to the site's challenging topography involves supporting and maintaining the integrity of the "metastable" slope and fulfilling the requirement to create a compliant pathway to the foreshore, whilst also removing non-native plant and invasive weed species and regenerating and enhancing the ecological health of the site.

The design approach focuses on the integration of landscape and structural elements with a "light touch". Incorporating recommendations from structural engineer Terpkos Engineering (Terpkos), coastal engineer Seashore Engineering (Seashore) and environmental consultant Tranen Revegetation Systems (Tranen), our proposal addresses both functional and aesthetic considerations to deliver a resilient, sympathetic and visually appealing foreshore inter-face.

Collaboration and Consultation:

Collaboration with Terpkos, Seashore, and Tranen will continue throughout detailed design and implementation to ensure structural integrity, strong ecological outcomes, and regulatory compliance.

Clearing and Revegetation:

The site contains a recognised environmental weed species, the Brazillian Pepper, along with a number of other non-native plant species. The aim is to remove all Brazillian Pepper by means of cutting down and treating with a chemical herbicide, and to strategically remove all other non-native species. The root systems of the Brazillian Peppers will remain insitu to stabilise the embankment until the revegetation of local species can establish.

The site will be reassessed after clearing in order to tailor the revegetation strategy to the resulting site conditions.

The revegetation strategy will reflect the original ecology of the site, and include the replanting of trees and plants from the Karrakatta vegetation complex, along with appropriate rushes and sedges to the foreshore interface. The re-introduction of local native species will enhance local biodiversity and provide habitat for local wildlife, promoting a positive ecological outcome and assisting with the long-term health and resilience of the surrounding foreshore and broader river system.

Foreshore Access Design:

The proposal is a foreshore access walkway from a supported Bondek landing entry at the top of the slope through a series of level changes, negotiated by stairs, linked by planes of metal floor grating. The base of the slope sits between 1.0 - 1.7 mAHD and rises to 13.6 mAHD. The lower portion of the stair will be a cantilevered landing, on pads set in and protected from coastal erosion by targeted rock revetment and softened with endemic sedges, rushes and shrubs. This design will mitigate large-level changes whilst providing a visually appealing amenity landscape.



img: Remiseparken / BOGL Landscape Architects



img: Jeffrey Longhenry



img: Terraforce



img: JBA

The foreshore rock revetment interface will consist of graded limestone armour placed on geotextile, providing stability and resilience against river dynamics. The revetment will be designed to accommodate climate-related river level rises.

Exposed limestone will be utilised to stabilise and bench the interface between the shoreline and proposed house pad levels, creating a natural appearance in harmony with the surroundings.

Construction and Materiality:

The construction approach adheres to relevant standards and guidelines, prioritising low-impact methods and materials where feasible. Light-touch materials such as aluminium grates and structural members will minimise visual intrusion whilst ensuring durability and compliance with regulatory requirements.

A combination of structural support methods will be used including a surefoot piling system and limestone retaining wall supporting a bon dek structural decking landing at the top entry,

Terraforce retaining blockwork at the mid node, and where necessary, concrete footings as slab on piling. The lower stairs will cantilever from pads shored up by a rock strategic placement of rock revetment, providing scour protection to the structure and slope.

The design will allow for the construction of the primary structure to be placed on site while environmental remediation and clearing works commence in parallel. The walkway flooring metal grating, will be easily installed into the primary structure.

07 DESIGN RESPONSE

GENERAL ARRANGEMENT

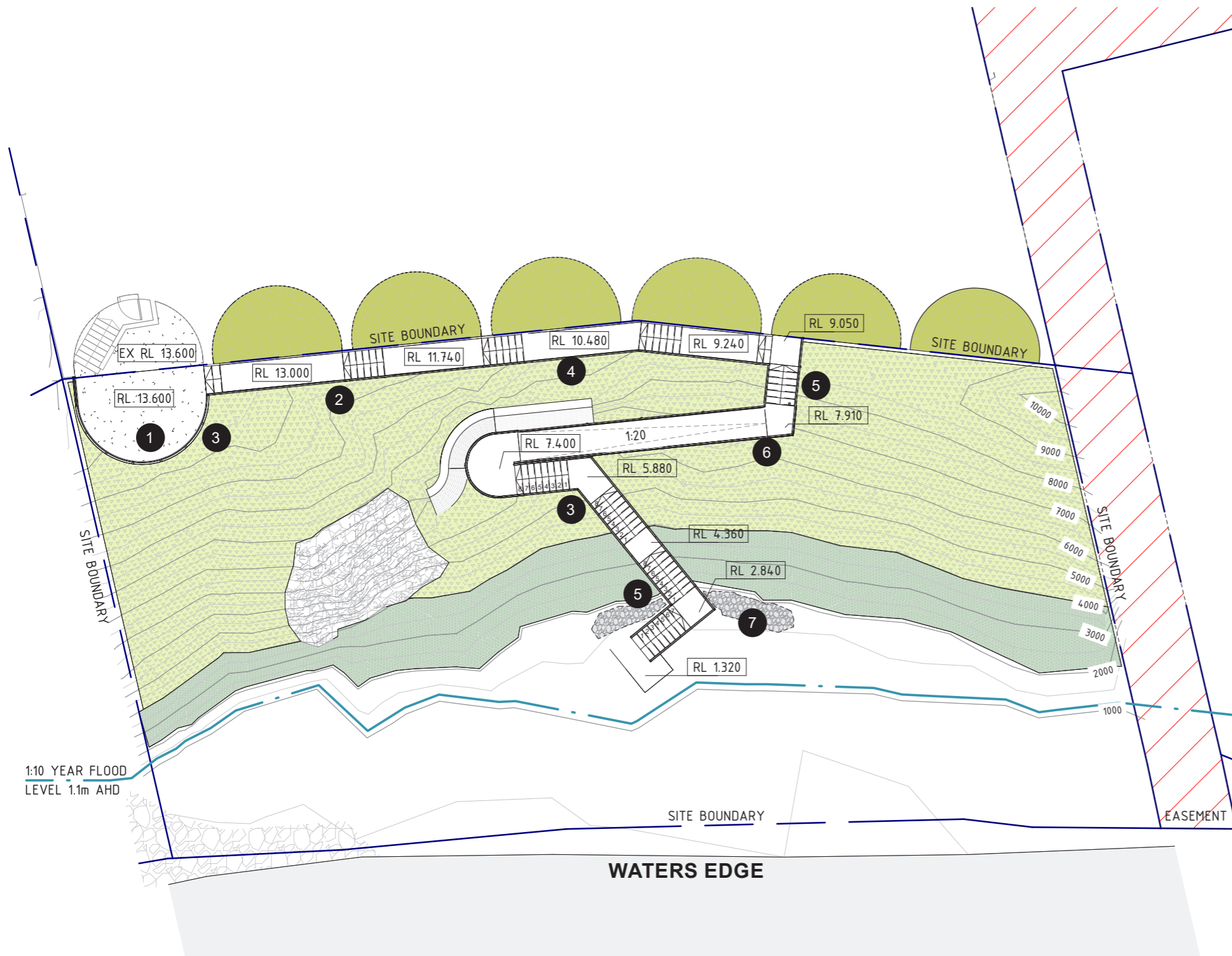

KEY

- 1 Bondek Landing to retained top landing.
- 2 "Light Touch" Aluminium Walkway Structure
- 3 Surefoot piling system.
- 4 Aluminium floor grate platform.
- 5 Stairs used to negotiate large level changes.
- 6 Balustrade.
- 7 Limestone rock revetment to back of shoreline to protect against erosion in high tides and storm surge events.
Proposed top of revetment as advised by the coastal engineer to be a minimum of RL +1.60 - +1.80 AHD.

PLANTING ZONES

- DESIGNED GARDEN PLANTING ZONE**
Consideration of southern aspect
Shaded with minimal water
Gravel mulch
- SLOPE REVEGETATION**
Karrakatta vegetation complex species plant species mix
Native shrub and groundcover planting to embankment
Strategic tree placements
- RIVERBANK ZONE**
Salt tolerant
Sedge planting utilised to visually soften revetment
Planted out of high water level

Planting to rear of shoreline interface with rock revetment to improve erosion control. Appropriate bioengineering to be used to protect the planting.

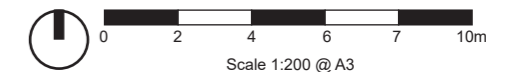

08 DESIGN RESPONSE

WALKWAY STRUCTURE AXONOMETRIC

Construction methodology provided by Terpkos.
This should be read in conjunction with all consultant's documentation.

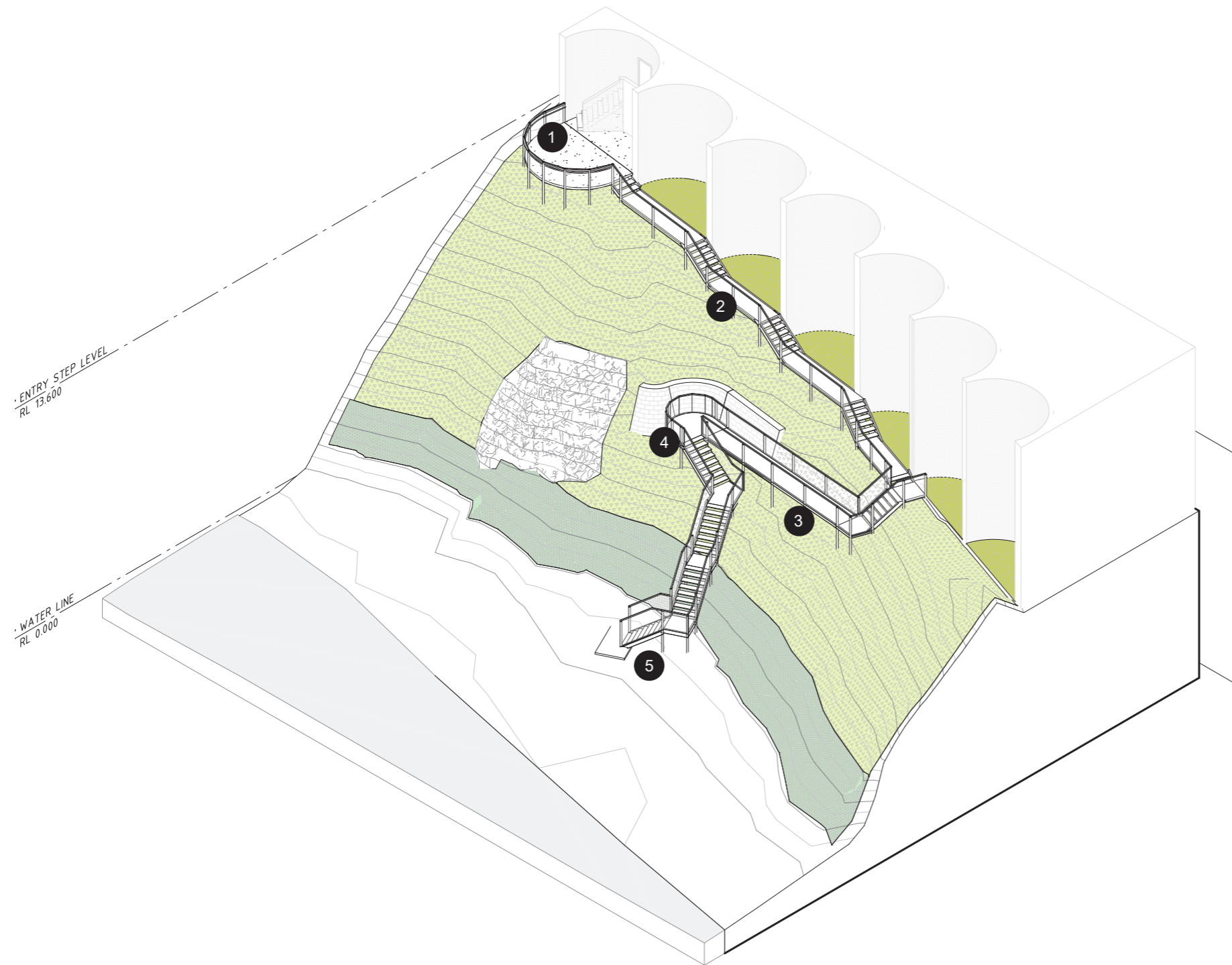

KEY

- 1 Bondek 120mm slab to limestone retained 140mm reinforced slab at top landing
RL 13.600 AHD
- 2 Top of slope
Post fixed to concrete footing & surefoot piling where slope allows
- 3 Post fixed to Surefoot Pile
- 4 Surefoot cap cast into concrete footing for Terraforce retaining.
- 5 Limestone rock revetment to back of shoreline to protect against erosion in high tides and storm surge events.
Proposed top of revetment as advised by the coastal engineer to be a minimum of RL +1.60 AHD and should be considered to be RL of +1.80 AHD for a 1:100 year storm event.

09 DESIGN RESPONSE

WALKWAY STRUCTURE & CONSTRUCTION METHODOLOGY

Construction methodology provided by Terpkos.

This should be read in conjunction with all consultant's documentation.

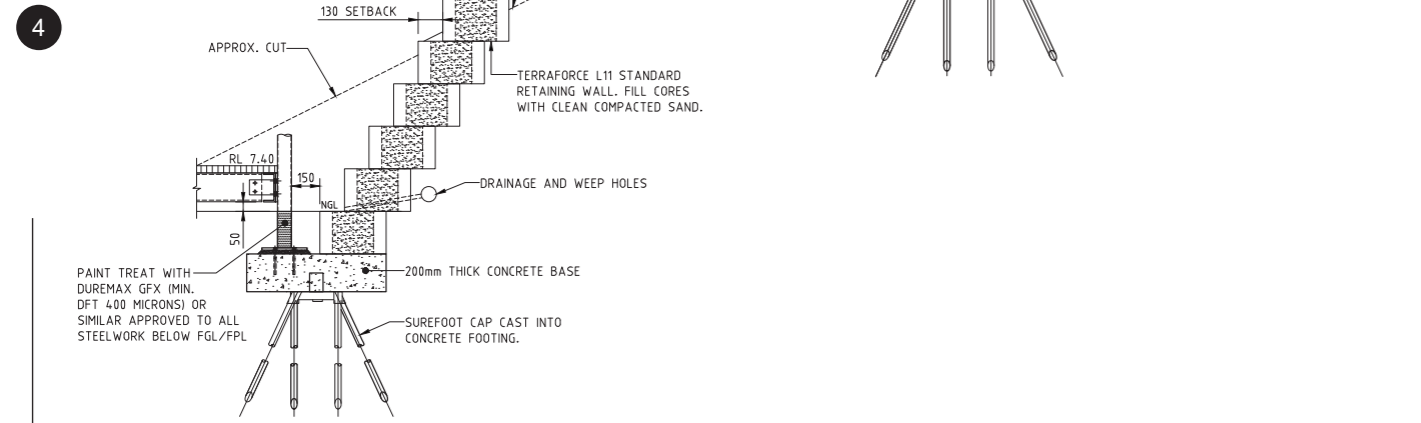
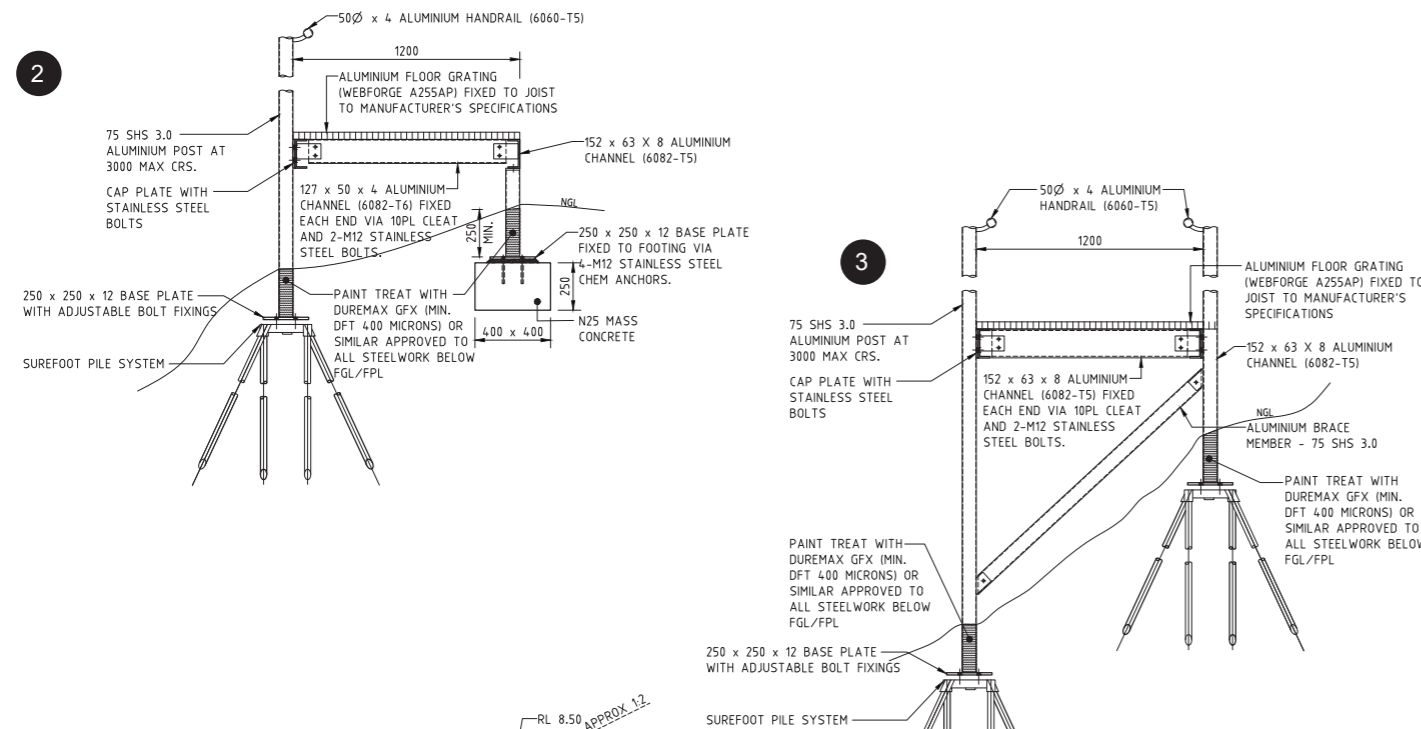
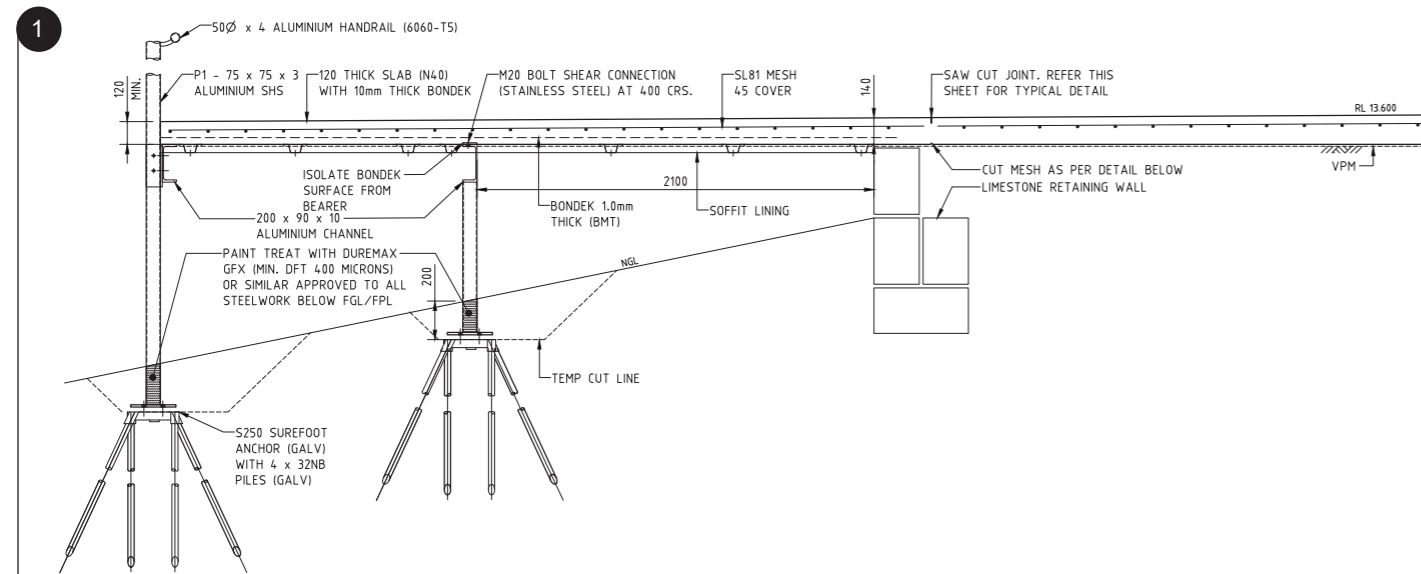

1. Cut back vegetation to slope in accordance with environmental consultants' requirements. Root systems must remain to limit movement in the upper surface of the slope. Seek direction from the consultant team if there is any concern with the slope stability.

2. After clearing the site, inspect the slope and re-survey it if necessary.

3. Demolish the existing path and stairs. Do not disturb the existing retaining wall to the main residence. Avoid placing construction loads or storing equipment at the top of the slope. If necessary, a 1.5kpa construction surcharge can be adopted for the works.

4. Locally cut back and excavate bases for Surefoot pile system and small concrete pads along the top of the walkway from platform RL 13.00 down to RL 9.05.

5. Surefoot piles are to extend a minimum of 3m below ground level. The contractor should note there is limestone rock at varying depths down the slope. Where piles hit rock, they are to be embedded a minimum 500mm into the rock in accordance with manufacturer's specification. The contractor must arrange for a representative from Surefoot to attend the site to provide advice for installing the first piles and to provide direction when piling into rock.

6. The walkway structure and mesh flooring can be installed along this upper length to allow greater access to the lower section of the platform. Maintain the 1.5 kpa construction surcharge limit while using the walkway for access.

7. Prepare bases for the remaining Surefoot piles for the lower section of the access walkway. Locally cut into slope to allow for Terraforce retaining wall footing. Install Surefoot piles as detailed and arrange the engineer's inspection prior to pouring.

8. Ensure protection of the slope during the works and provide temporary shoring as necessary. Prevent sand/debris from backfilling over Surefoot bases.

9. Install the remaining access walkway structure through to the platform at RL 7.40. Maintain the 1.5 kpa construction surcharge limit while using the walkway for access.

10. Coordinate construction and rock protection of the lower landing pad.

11. Install remaining Surefoot piles and access walkway structure as documented.

12. Arrange engineer's inspection to verify works.

13. Revegetation consultant team to advise on future planting to maintain the stability of the upper surface of the slope.

Construction Methodology, provided by Terpkos. This should be read and followed in conjunction with environmental/revegetation specialist methodology and coastal engineer's documentation.

10 DESIGN RESPONSE

CLEARING, SLOPE STABILISATION & EROSION CONTROL STRATEGY

PHASE 1
SITE CLEARING & WEED MANAGEMENT
PROPOSED TO TAKE PLACE APRIL 2024

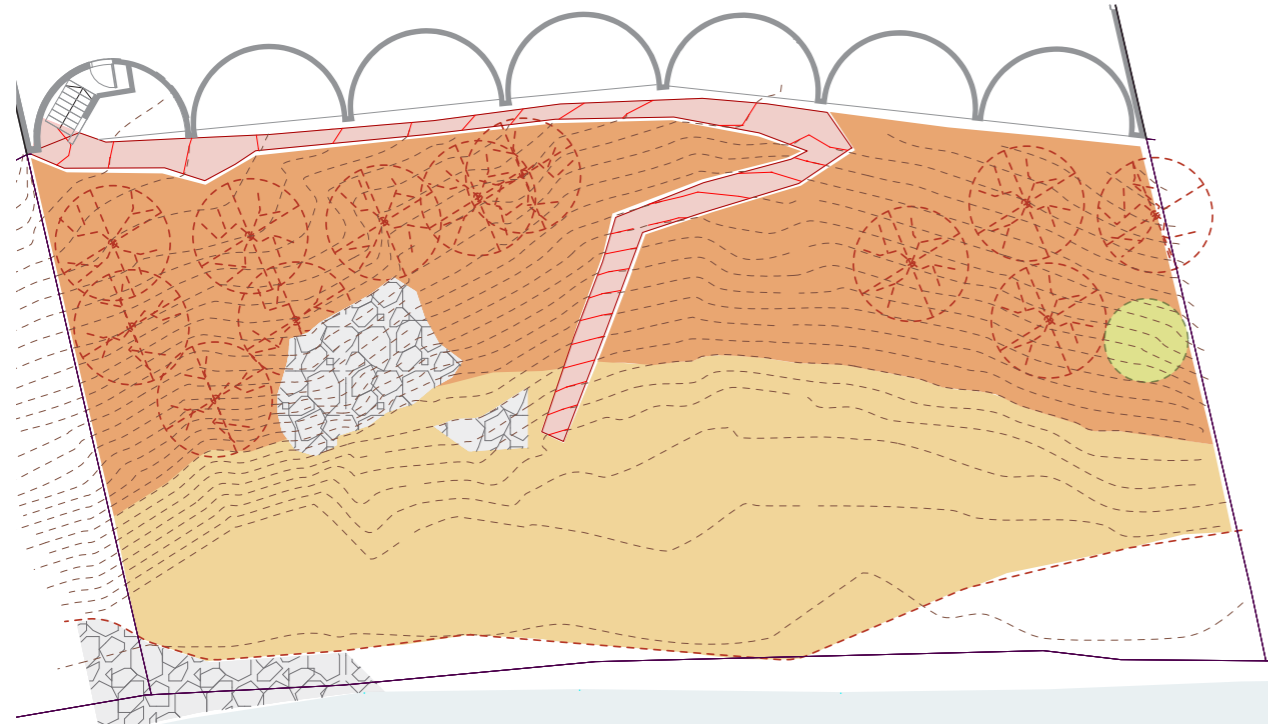

LEGEND

- Demolish existing brick path and stair
- Retain native species
- Cut & herbicide Brazillian Pepper
Strategic removal of non-natives
Retain roots for slope support
- Steep slope
Harnessing requirements
Backpack spraying
Hand removal
- Hand removal and riverine appropriate herbicides.
Dashed red line indicates surveyed extent of vegetation

The environmental consultant, Tranen has provided the clearing and revegetation methodology. This should be read and followed in conjunction with all consultant documentation.

The base of the slope sits between 1.0 - 1.7 mAHD and rises to 13.6 mAHD. It is classed as "metastable" by Galt Engineering. Rope access and harnessing will be necessary during site clearing.

Strategic removal of non-native species to occur prior to planting. Root systems of some trees left in place. Erosion control measures will be implemented, assisting with soil stabilisation.

Weed control events are typically completed in winter, spring, and summer each year. The initial clearing will target main weed species in their growth period, including the systematic removal of the on-site Brazilian Pepper and other non-native vegetation. Some large Tuart trees were observed and will be retained.

Selective herbicides that are appropriate to the target species will be used. In close proximity to the river, only herbicides safe for use in these environments will be used.

PHASE 2
SURFACE PREPARATION & EROSION CONTROL

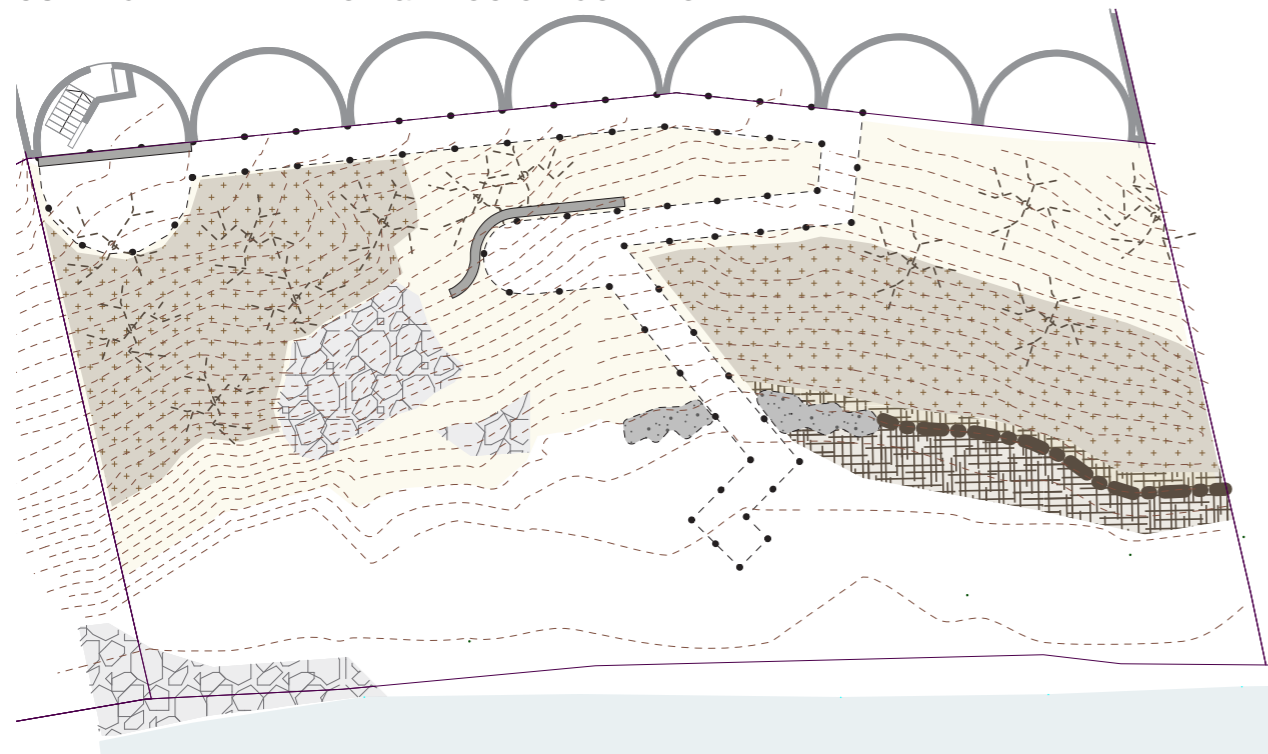

LEGEND

- Roots retained for slope support
- Retaining
Limestone at top landing
Terraforce at mid node
- Structure in place (diagrammatic)
Lower stairs to cantilever from pads
- Rock revetment where necessary
- Where appropriate:**
- Brush mattressing / much
- Coir logs
- Coir netting / geotextiles

The steep slope is identified as "metastable" by Galt Engineering, necessitating intervention to maintain its integrity. Non-native species will be strategically removed before revegetation planting, with some tree root systems left in place, reducing damage and erosion to the slope if removed, while providing structure for slope support.

Erosion control measures such as coir netting, coir logs, and brush fencing will be considered after clearing. Revegetation and stabilisation planting using native species will occur during winter, with surface preparation to mitigate runoff and improve plant survival.

Stabilisation measures providing flexibility, such as brush mattressing and mulch may be required. The requirements for site surface preparation will be reviewed following vegetation removal and the re-assessment of site stability, with additional stabilisation options proposed if required.

Seashore Engineering will design the foreshore stabilisation, with particular consideration to the area surrounding the lower landing portion of access stairs. The design will include rock pitching with a geotextile layer for erosion reduction.

11 DESIGN RESPONSE

REVEGETATION, MONITORING & MAINTENANCE STRATEGY

PHASE 3 REVEGETATION & PLANTING

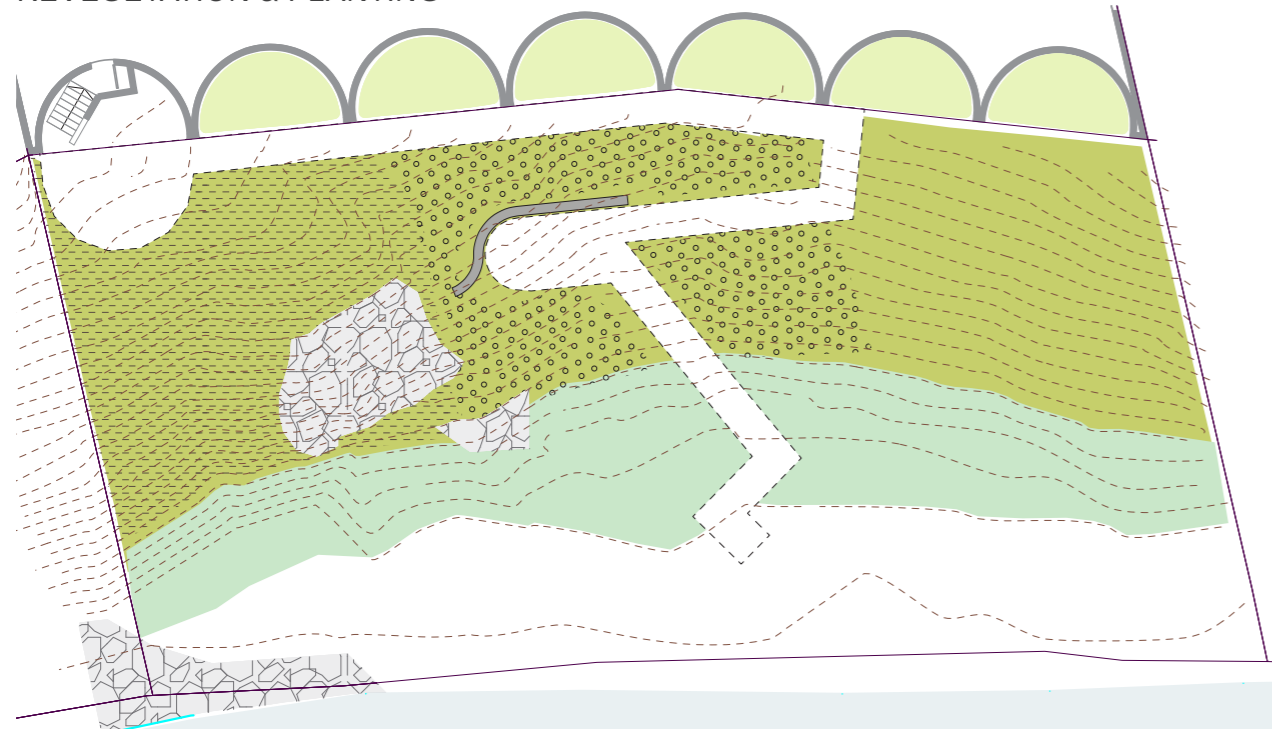

LEGEND

- Karakatta Complex Planting Priority Areas:**
- Fast growing, high density forestry and deep cell tubestock with fertiliser tablets
- Bare / exposed slope stabilisation
- Steep slope revegetation
-
- Riverbank Zone
- Designed Garden Zones

A nominal plant species list focusing on the Karakatta Complex – Central and South has been developed by JBA and Tranen, prioritising fast-growing species for soil stability and cover.

Tubestock, supplied in forestry tubes or deep cells, will be used for planting, ensuring hardy seedlings with developed root systems. Plant orders from native nurseries must be placed in advance, typically before September of the preceding year.

Due to steep slopes, planting may require abseiling with a kidney bucket and hand trowel, necessitating sturdy anchor points across the slope. Coordination with the contractor building the walkway can facilitate this process.

Planting on the slope is expected to occur during naturally wet months, with irrigation set up to enhance survival rates. Fertiliser tablets are recommended to compensate for nutrient deficiencies on slopes, as organic matter may be lacking, and tablets provide nutrients directly to seedlings while minimising weed interference. The Riverbank Zone will be planted prior to the winter storms and will include a selection of salt tolerant species.

The Designed Garden Zones will be addressed at a later stage.

PHASE 4 MONITORING & MAINTENANCE

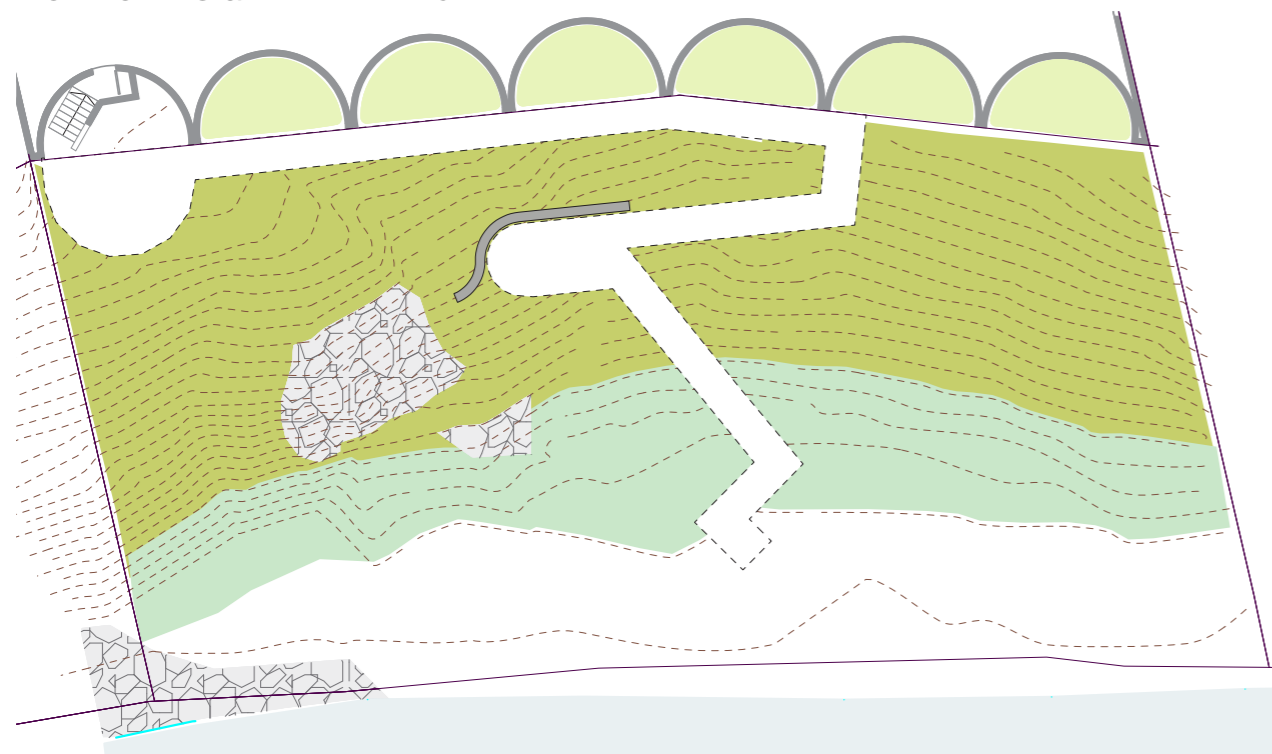

LEGEND

- Karakatta Complex
- Riverbank Zone
- Designed Garden Zones

Two informal monitoring events per year are recommended during spring and autumn to assess growth. Results will determine if remedial actions like weed control and infill planting are needed.

Maintenance will continue for five years post-installation to establish a self-sustaining vegetation community.

Weed control and infill planting will follow the installation plan unless issues arise, such as poor species establishment or inadequate erosion control.

Completion criteria, including species richness and erosion control, will be developed after existing vegetation removal.

Ongoing weed control will be necessary throughout the maintenance period, with surface preparation and erosion control strategies devised after vegetation removal.

12 DESIGN RESPONSE

PLANTING PALETTE

Planting palette developed by Tranen and Josh Byrne & Associates.
This should be read in conjunction with all consultant's documentation.

SHRUBS AND STRAPPY PLANTS

Acacia cochlearis



Image: R Clark

Acacia cyclops



Image: honkeynuts.com.au

Acacia pulchella



Image: gardentags.com

Acacia rostellifera



Image: R Clark

Allocasuarina humilis



Image: friendsofqueensparkbushland.org.au

Calothamnus quadrifidus



Image: katanninglandcare.org.au

Dianella revoluta



Image: gardeningwithangus.com.au

Grevillea crithmifolia



Image: Plantrite

Hakea prostrata



Image: friendsofqueensparkbushland.org.au

Hardenbergia comptoniana



Image: greatoceanroadnursery.org.au

Hemidra pungens



Image: oleantaseeds.com.au

Melaleuca huegelii



Image: honkeynuts.com.au

Melaleuca seriata



Image: honkeynuts.com.au

Olearia axillaris



Image: cottesloecoastcare.org

Patersonia occidentalis



Image: australianseed.com

Scaevola crassifolia



Image: Geographe Plants/R. Clark

Scaevola nitida



Image: Geographe Plants/R. Clark

Templetonia retusa



Image: australianseed.com

TREES

Melaleuca cuticularis



Image: Apace

Corymbia callophylla



Image: instanttreenursery.com.au

Eucalyptus gomphocephala



Image: Lucid Central

RUSHES AND SEDGES

Juncus kraussii



Image: Apace WA

Lepidosperma gladiatum



Image: rewildperth.com.au

13 DESIGN RESPONSE

TYPICAL PLANTING DETAILS

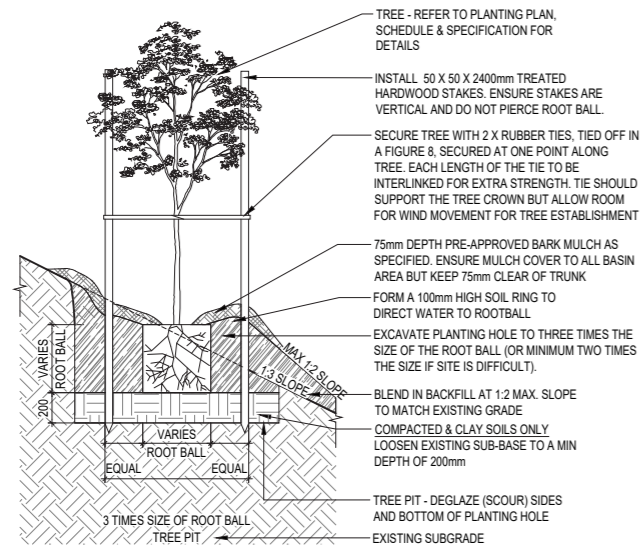

TYPICAL DETAIL - SEMI-ADVANCED TREE PLANTING ON EMBANKMENTS STEEPER THAN 1 IN 6

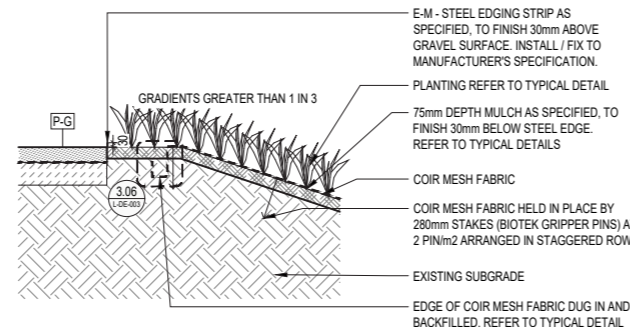

TYPICAL DETAIL - PLANTING ON SLOPE

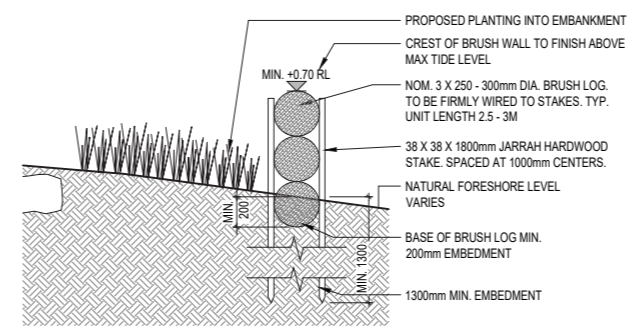

TYPICAL DETAIL - BRUSH WALLING

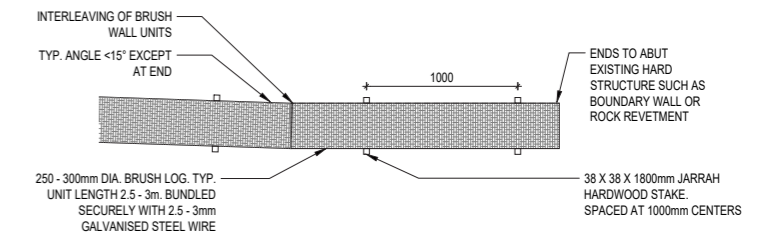

TYPICAL PLAN - BRUSH WALLING CONTINUOUS PLACEMENT

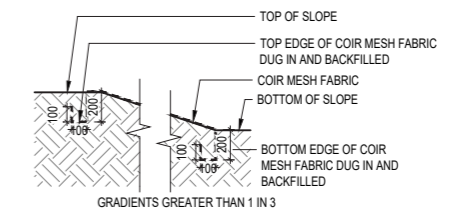

TYPICAL DETAIL - BIODEGRADABLE GEOTEXTILE FABRIC

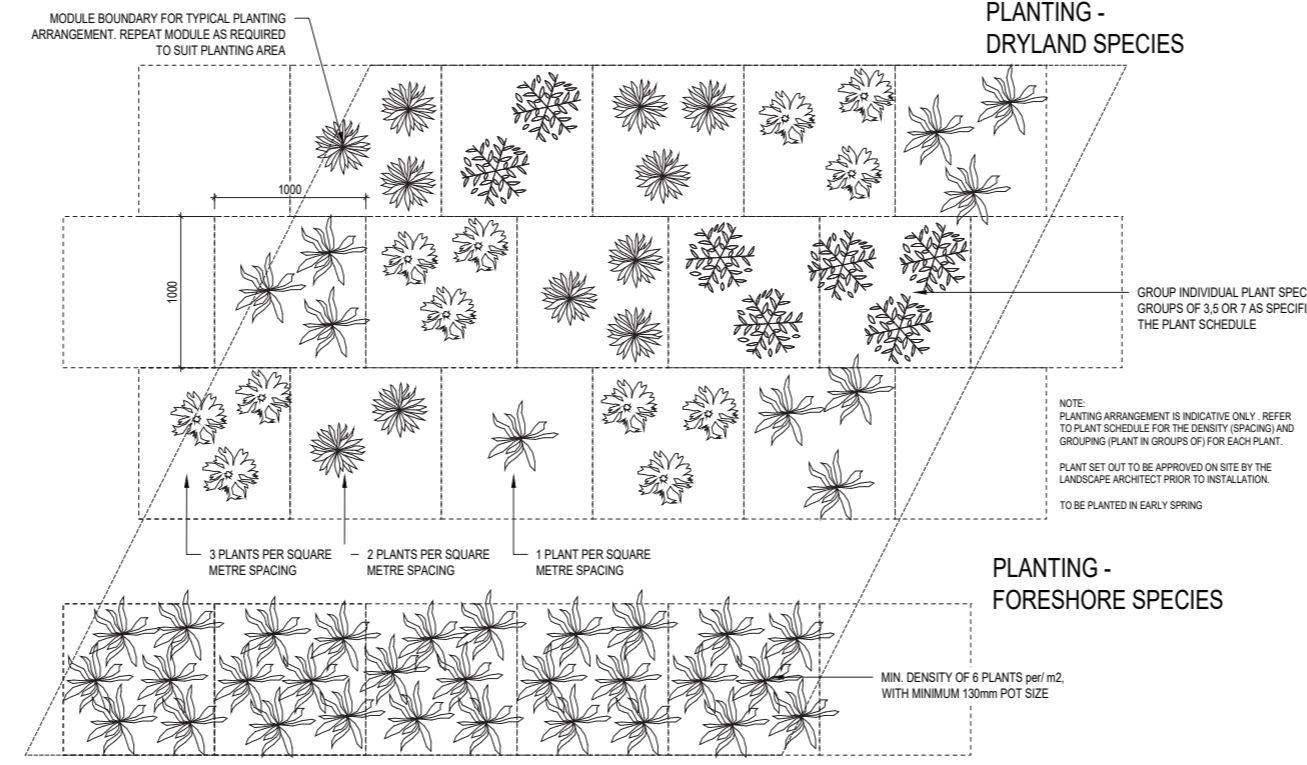

TYPICAL LAYOUT PLAN - PLANTING MIXES

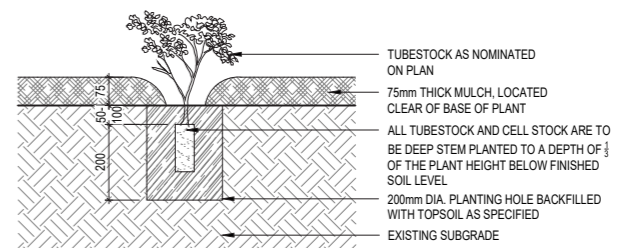

TYPICAL DETAIL - TUBESTOCK PLANTING METHOD

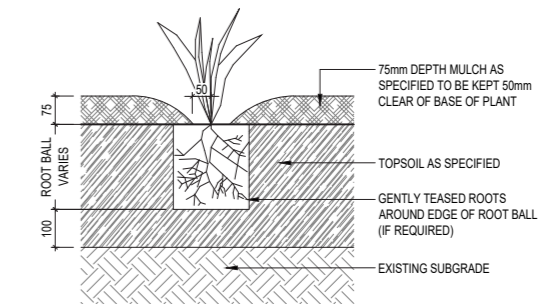

TYPICAL DETAIL - SHRUB PLANTING

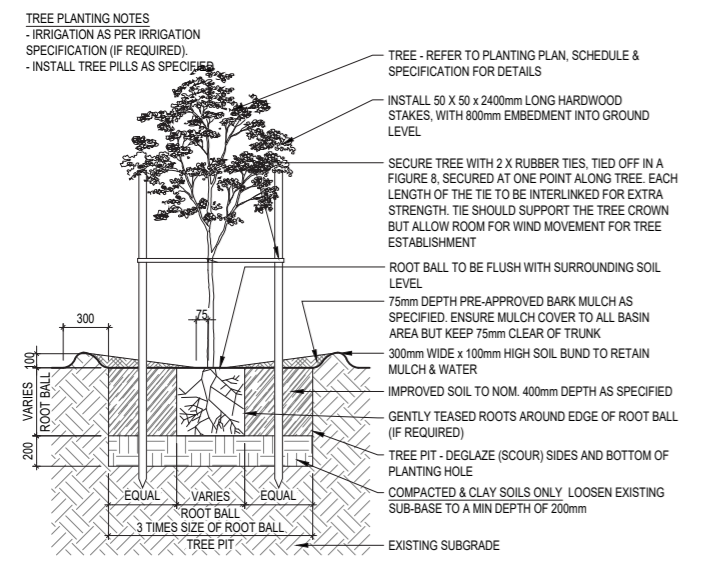

TYPICAL DETAIL - SEMI-ADVANCED TREE PLANTING

14 WALKWAY LAYOUT

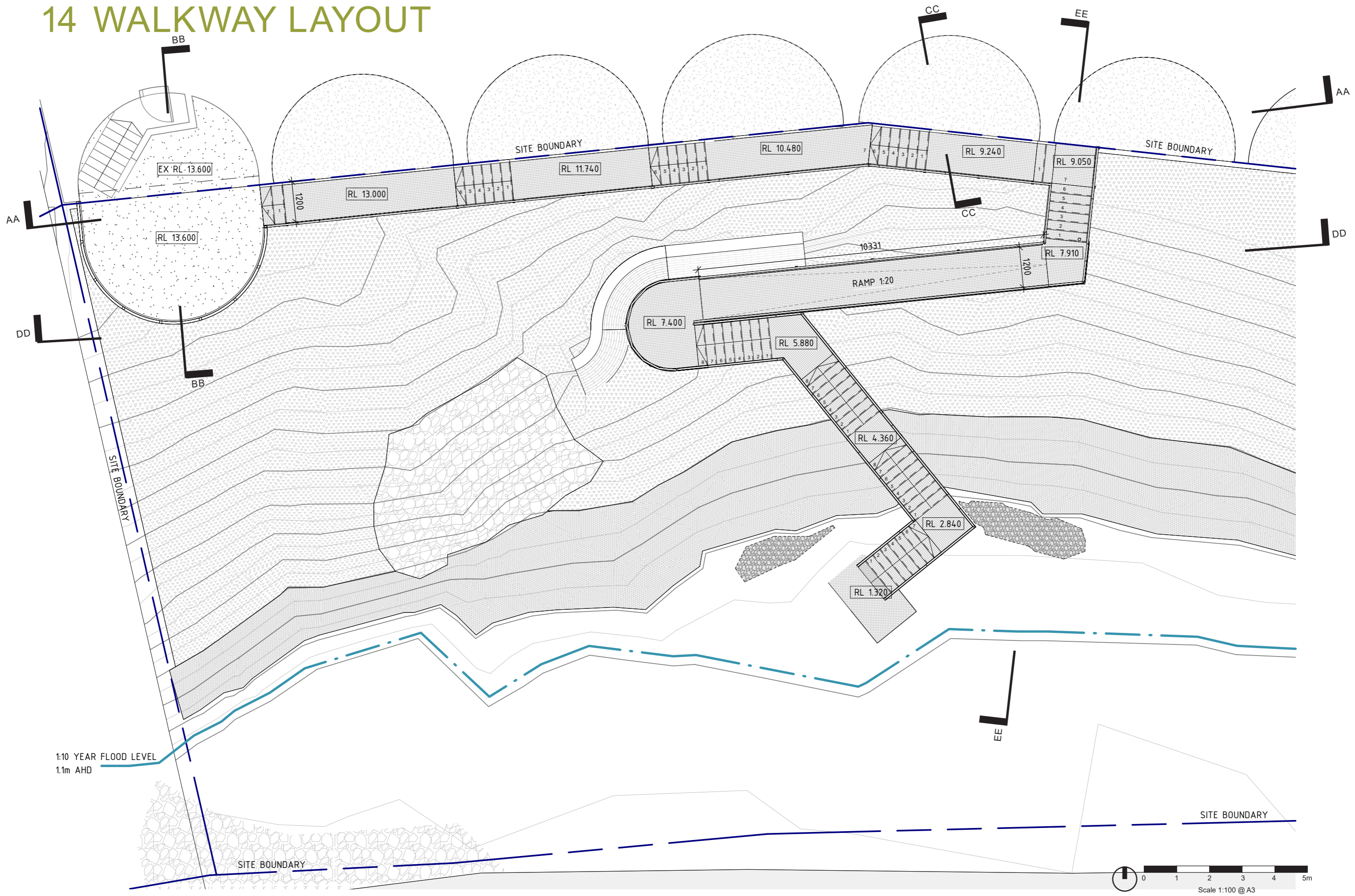

15 ELEVATION

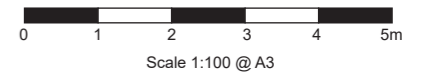
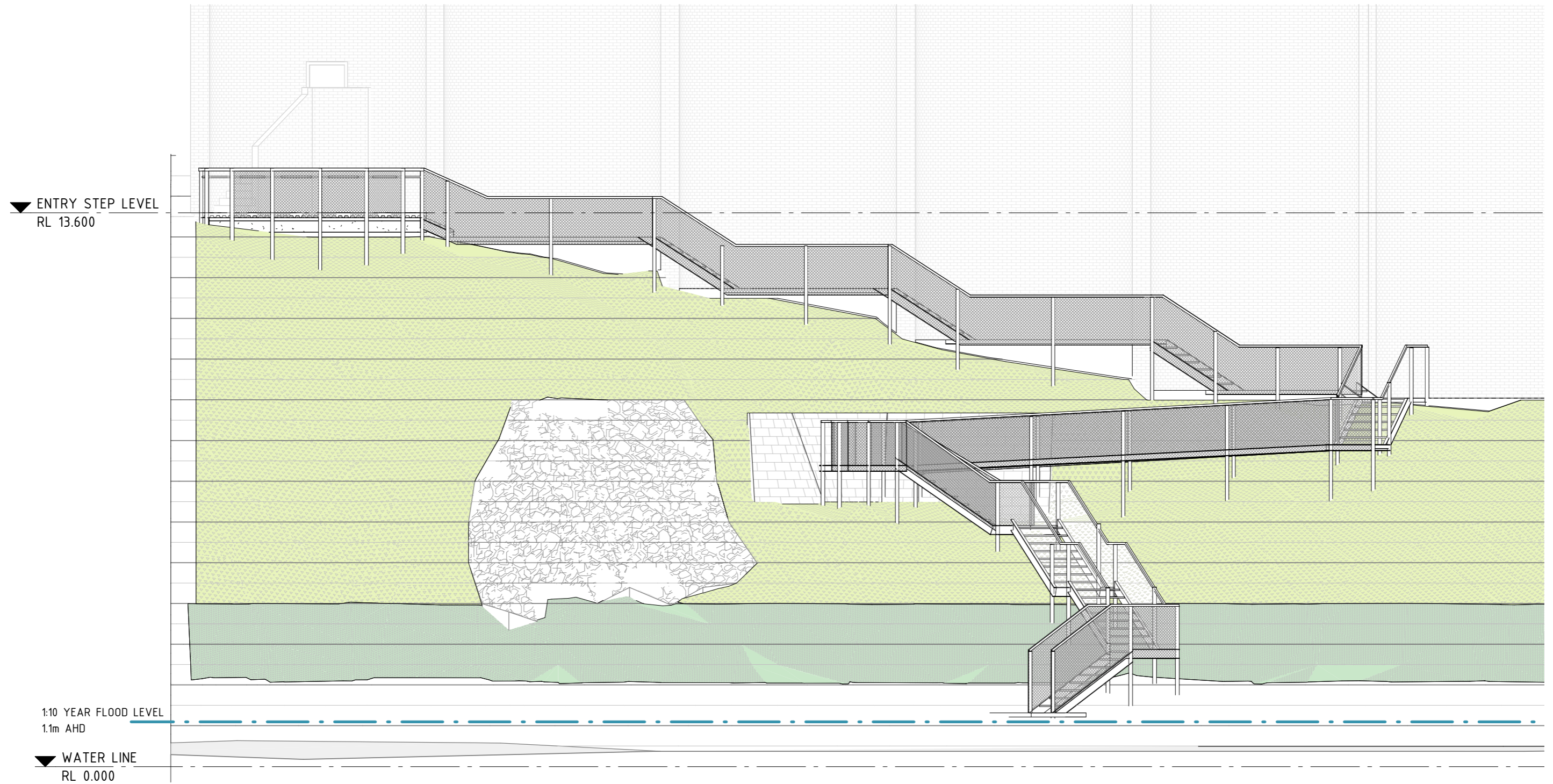

16 SECTIONS

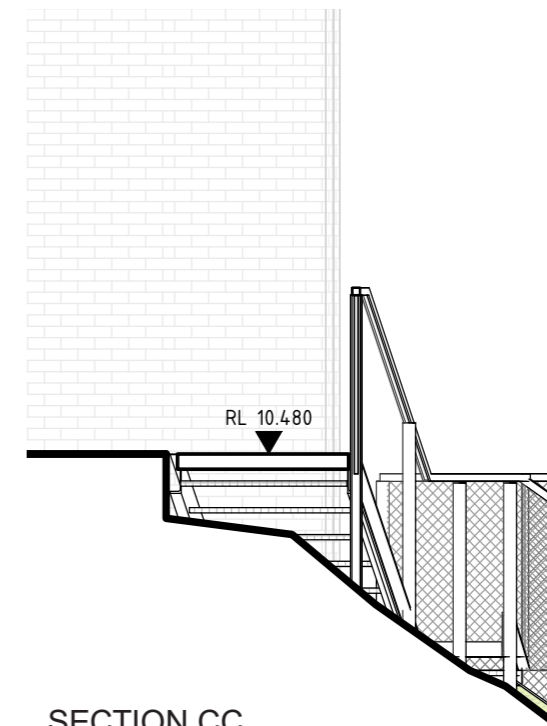
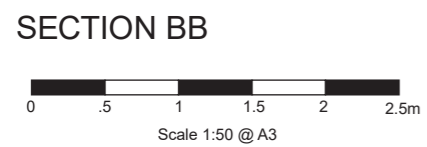
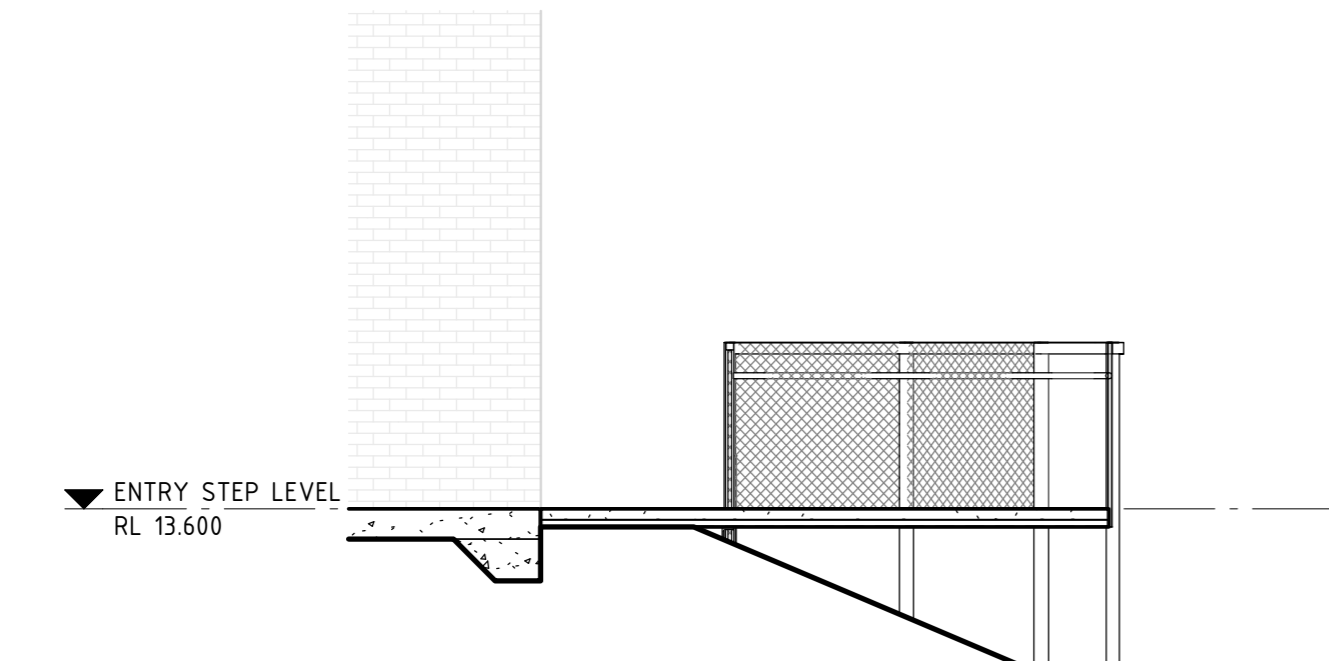
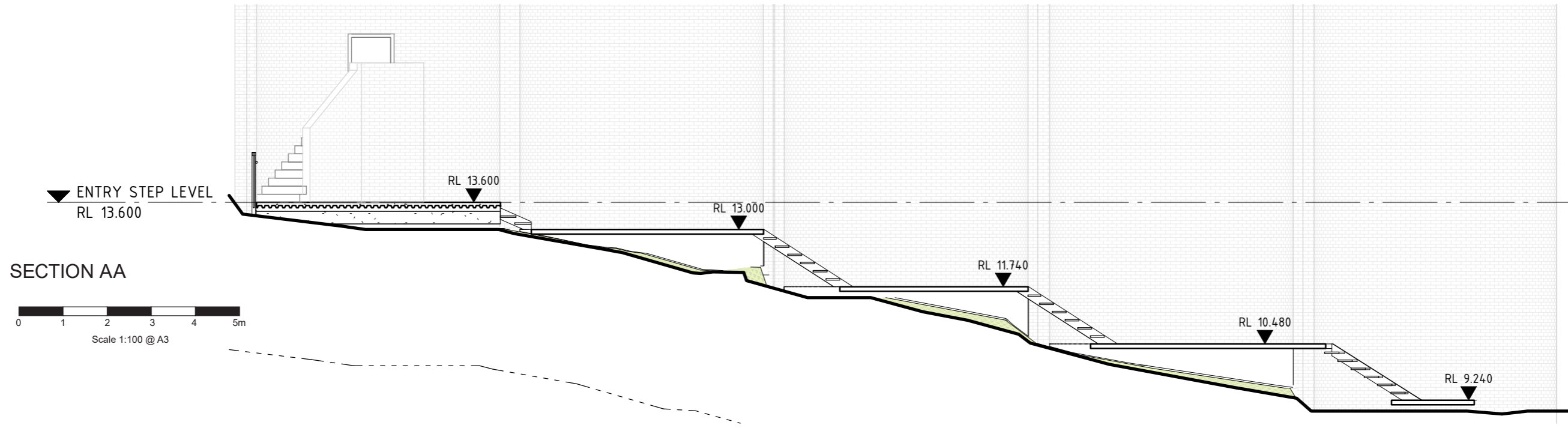

17 SECTIONS

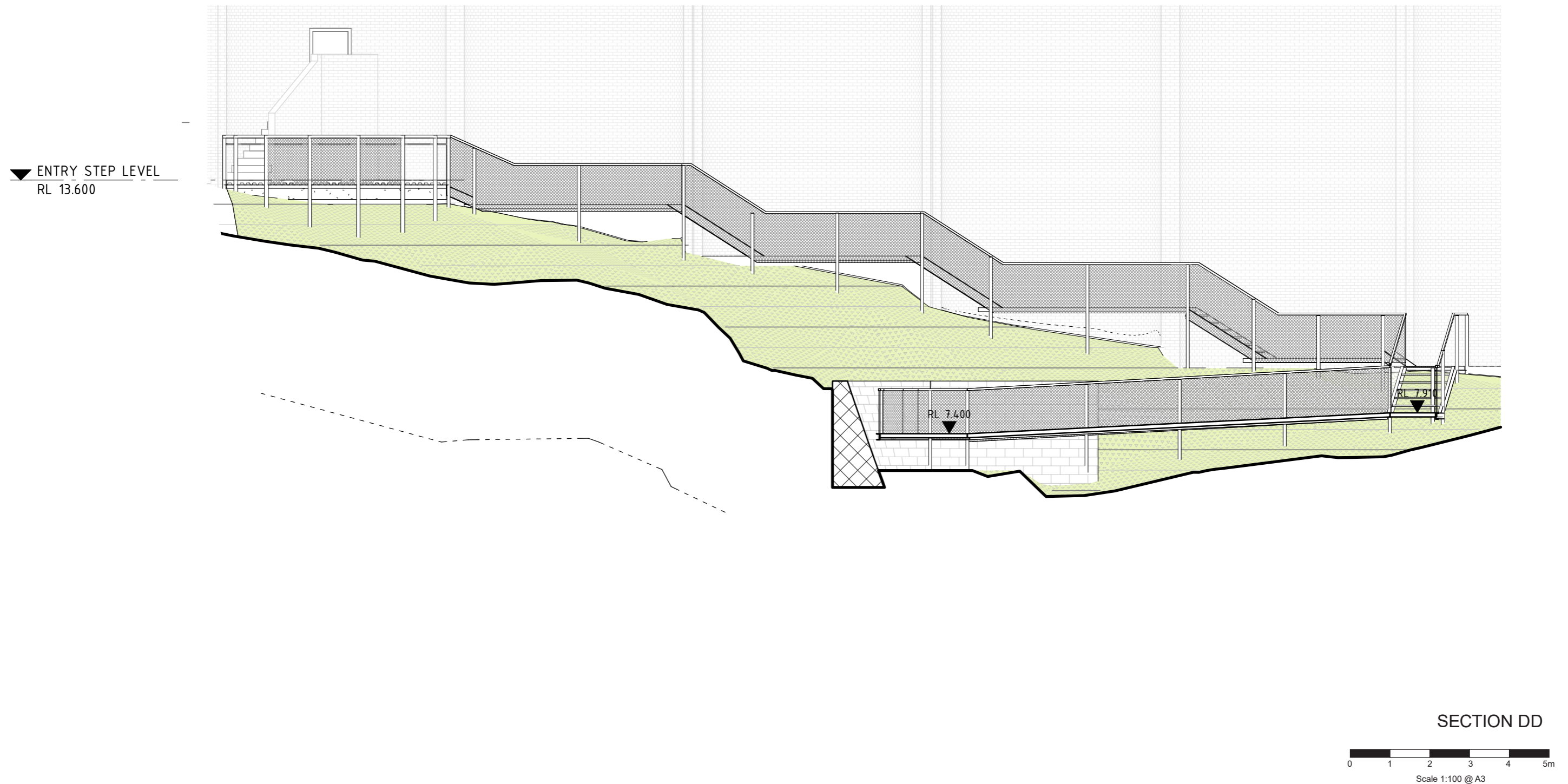

18 SECTIONS

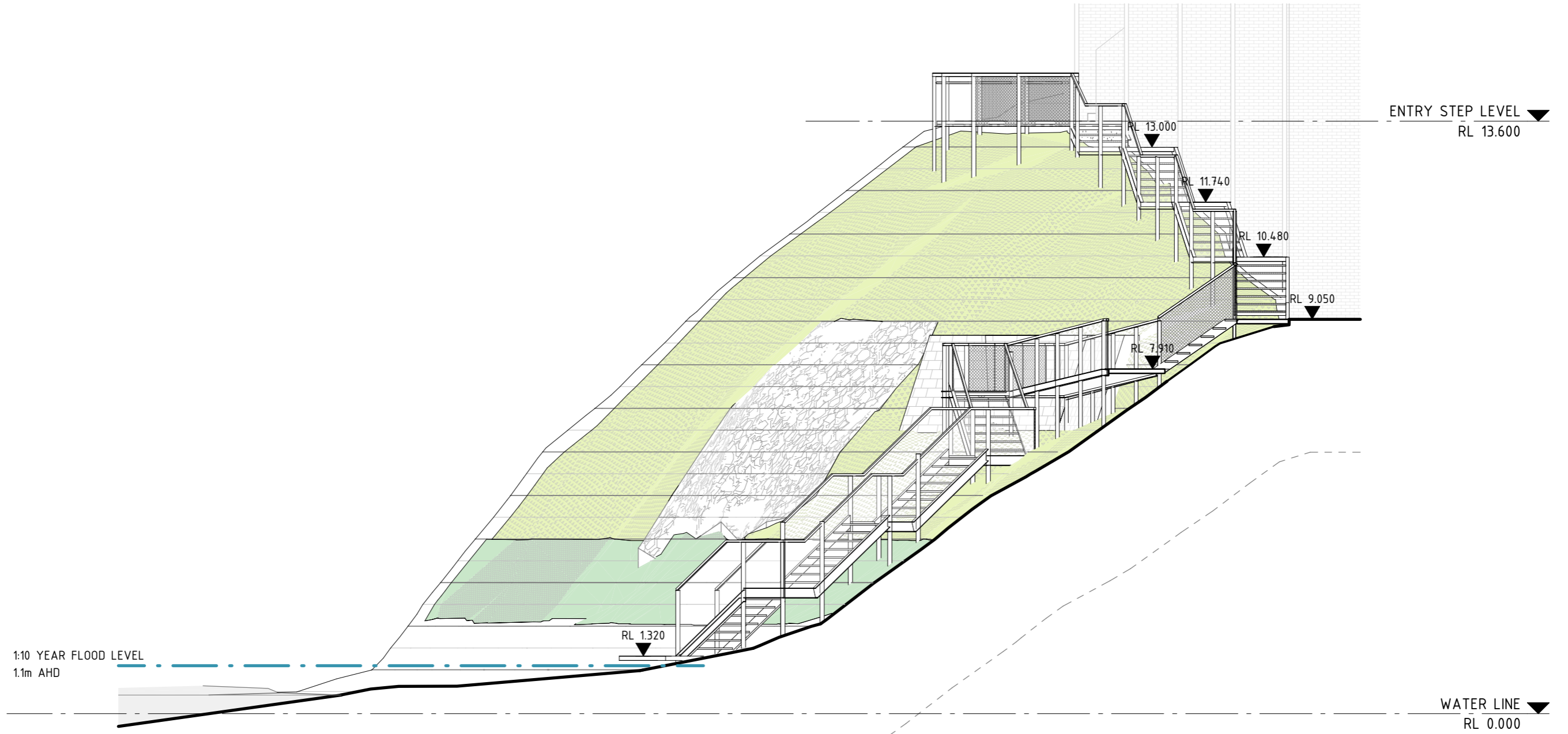

SECTION EE

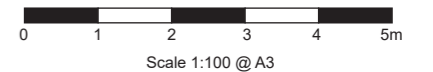



JOSH BYRNE & ASSOCIATES

LANDSCAPE • SUSTAINABILITY • COMMUNICATIONS

T 08 9433 3721 E design@joshbyrne.com.au W joshbyrne.com.au

A Suite 109 Atwell Buildings 3 Cantonment Street Fremantle WA 6160

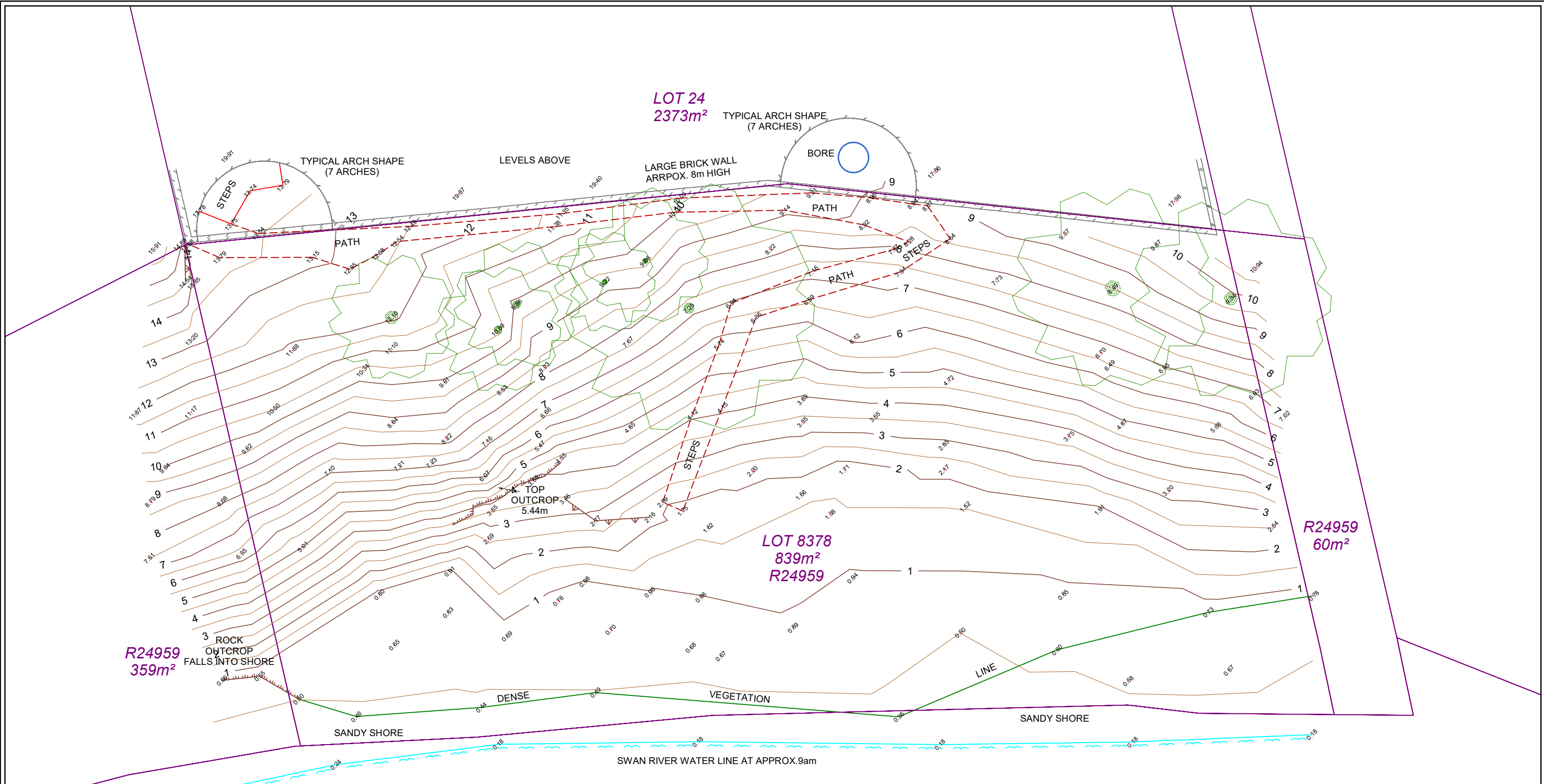

Existing boundaries have been extracted from Landgate's Spatial Cadastral Database, which is only a model of the cadastre. The depicted boundary locations are a graphical representation only and as they have not been re-established by survey, MNG does not guarantee the position unless stated otherwise.
 Re-establishment of lot boundaries by a Licensed Surveyor is recommended for any works on or about a boundary.
 This note is an integral part of this plan.

This survey has been completed to CLASS 2 Accuracy
 Horizontal Accuracy ± 20mm
 Vertical Accuracy ± 20mm
 This note is an integral part of this plan.

Surface features and levels have been surveyed to meet the requested scope of works accuracy. The surface may be contoured to depict topography or defined only by spot heights. For clarity on hard copy some level information is not shown, refer to 3D digital file.
 Above ground indicators (markers) of underground services are located where visible.
 Third parties utilising this information should confirm the capture accuracies meet requirements prior to use.
 This note is an integral part of this plan.

Rev.	Initial Issue	Description	Drawn	Date	Checked
A	Initial Issue		MGH	01/09/23	MJ

SCALE 1:150 @ A3
 0 4 8
 ALL DISTANCES ARE IN METRES
 For a true to scale reproduction of this plan, plot it to A3 with the Pacing Scaling set to None.

The contents of this plan are current and correct as of the date stated within the revision panel. All consultants and persons wishing to utilise this data should satisfy themselves of this plan's currency by contacting the McMullen Nolan Group.

Surveyor:- MGH
 Survey Date:- 31/08/2023
 Precal/Cad:- 31/08/2023

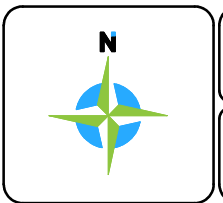

The boundaries shown on this plan were not re-established as part of this survey, therefore this plan does not guarantee their accuracy. Existing easements, encumbrance or interest are not depicted and a title search is recommended to obtain this information. Re-establishment of the cadastral boundaries is recommended for any proposed works on or near existing boundaries.

MCMULLEN NOLAN GROUP
 Level 1, 2 Sabre Crescent
 Jandakot, W.A. 6164
 PO Box 3526, Success
 W.A. 6954, Australia
 Offices in: Perth | Melbourne | Kimberley | South West WA

Tel: (08) 6436 1599
 Fax: (08) 6436 1500
 info@mngsurvey.com.au
 www.mngsurvey.com.au
 ABN 90 009 363 311

**LEVELS SURVEY of EMBANKMENT AREA
 RESERVE 24959**

CLIENT: **JOSH BYRNE & ASSOCIATES**

Project Mng: MATT JILLEY Datum: PCG94 / AHD

105901 - DE - 001 - A

Job Number	Type	Plan Number	Revision
105901	DE	001	A



Report on:

**GEOTECHNICAL STUDY
PROPOSED RESIDENTIAL DEVELOPMENT
26 JUTLAND PARADE
DALKEITH**

WAG230419-01 001 R Rev0

Submitted to:

Josh Byrne & Associates
109/3 Cantonment Street
FREMANTLE WA 6160

28 September 2023

CONTENTS

1. INTRODUCTION	3
2. KEY FINDINGS	3
3. SITE DESCRIPTION AND PROPOSED DEVELOPMENT	3
4. PROJECT OBJECTIVES	4
5. FIELDWORK	5
5.1. Infiltration Test Results	5
6. SITE CONDITIONS	5
6.1. Geology	5
6.2. Ground Model	6
6.3. Groundwater	6
7. GEOTECHNICAL ASSESSMENT	7
7.1. Summary	7
7.2. Geotechnical Model	8
7.3. Shallow Footings	8
7.4. Piled Foundations	9
7.5. Riverbank (Slope) Works	9
7.5.1. Slope Stability	10
7.5.2. Foundations	10
7.5.3. Construction Considerations	11
7.6. Construction Recommendations (Residence)	11
7.7. Future Investigations	11
8. CLOSURE	12

Table 1: Summary of Proposed Development 4
Table 2: Summary of Field Data 5
Table 3: Infiltration Test Results..... 5
Table 4: Summary of Geology Mapping 5
Table 5: Summary of Units..... 6
Table 6: Summary of Groundwater 6
Table 7: Summary of Geotechnical Assessment 7
Table 8: Summary of Units..... 8
Table 9: Isolated Pad Footing Allowable Bearing Pressures and Estimated Settlements..... 8
Table 10: Isolated Strip Footing Allowable Bearing Pressures and Estimated Settlements..... 9
Table 11: Pile Design Parameters – CFA Piles 9

Figure 1: Site and Location Plan

- Appendix A: Site Photographs
- Appendix B: Cone Penetration Test Results
- Appendix C: Borehole Reports
- Appendix D: Perth Sand Penetrometer Test Results

Standard Geotechnical Definitions, Recommendations, Requirements and Limitations

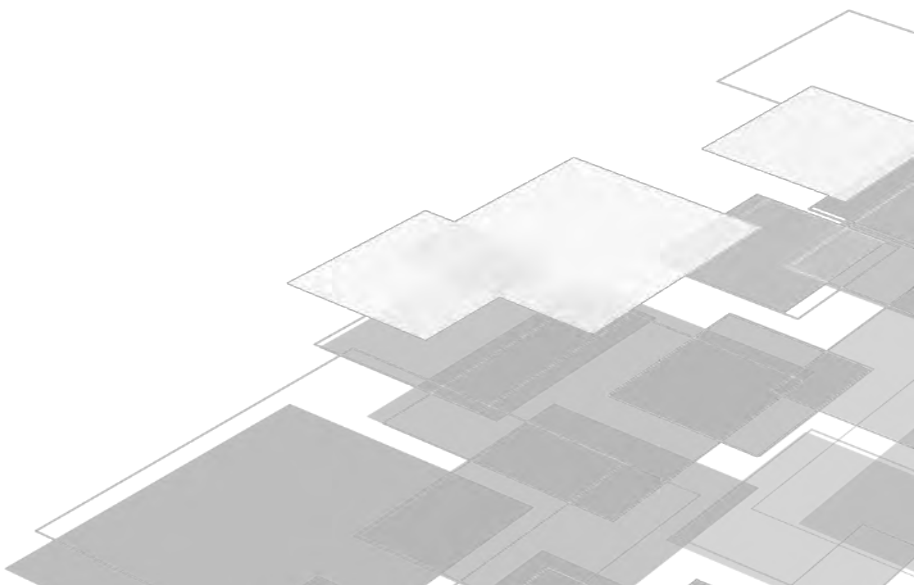

1. INTRODUCTION

This report presents the outcomes of Galt Geotechnics' (Galt's) geotechnical study for the proposed residential development at 26 Jutland Parade, Dalkeith ("the site").

This report is to be read in conjunction with the appended "Geotechnical Definitions, Recommendations, Requirements and Limitations" which includes the GDR clauses referred to in the report.

2. KEY FINDINGS

Proposed Residence

The site is suitable for construction of the proposed residence. Careful design of stormwater disposal is required to reduce risks associated with the existing arched retaining structure. Preliminary design parameters have been recommended for piling (for founding of the building and/or boundary retention). Additional investigation of the limestone is required.

Slope Along Swan River

The existing slope along the Swan River is considered to be "metastable", with a factor of safety less than typically required for an engineered slope. Vegetation must be maintained and encouraged.

Any new structures (walkways etc.) must be piled and/or anchored (i.e., using SureFoot founding or similar), with installation to a minimum depth of 3 m, or 0.5 m into limestone. Matting or re-vegetation of any small areas cleared during construction is recommended.

3. SITE DESCRIPTION AND PROPOSED DEVELOPMENT

The site is currently occupied by a large house, close to the southern boundary of the site. An arch-shaped brick retaining structure is present along the southern boundary and is between 5 m and 8 m in height. Provided drawings show this is supported by "dead-man anchors"

Historical aerial imagery indicates that the existing residence and associated structures were constructed sometime between 1970 and 1974. Little change has occurred at the site since this construction.

The slope from the southern boundary to the Swan River appears to have always been densely vegetated.

Masonry stairs are present from the southern lot boundary to the Swan River with a narrow area of cleared vegetation.

A double storey house over a double basement is proposed. Pedestrian access to the Swan River is likely to be along the same general alignment as existing masonry steps. We expect that the new steps will be piled or anchored.

Table 1: Summary of Proposed Development

Item	Comment
Site Surface Levels	Residence Level – RL 18 m AHD at southern retaining wall to RL 24 m AHD at Jutland Parade Slope Level – RL 13 m to RL 10 m AHD at the top of the slope to around RL 0.5 m AHD at the Swan River
Basements Proposed	Two levels below ground are proposed at a lowest elevation of around RL 13.5 m AHD.
Cut/Fill	Cut will be required for the basements, with excavated material to be removed off site.
Finished Floor Level	Residence – Upper roof slab will be at RL 29 m AHD Slope – Slope levels are not proposed to be altered, as access will be facilitated by structures
Proposed Development	4-5 level residence (2 levels below ground, 2-3 levels above ground) Piled jetty/stair structure for access to Swan River
Assumed Footing Type	Combination of shallow footings, slabs on-ground and piles.
Assumed Retaining Walls	Existing arched retaining structure (with dead-man anchors) will remain and be modified to meet design requirements. Piled retaining walls assumed along the north, west and east as required.
Assumed Stormwater Disposal	On-site via soakwells.
Assumed Sewage Disposal	Sewer.

NOTES: 1. FFL – finished floor level

4. PROJECT OBJECTIVES

The objectives of the study were to:

- assess subsurface soil and groundwater conditions across the site;
- provide recommendations on suitable footing systems for the proposed development;
- provide allowable bearing pressures and settlement estimates for shallow foundations;
- provide a site classification(s) in accordance with AS 2870-2011 “Residential Slabs and Footings”;
- provide recommendations and geotechnical design parameters for earth retaining structures, including temporary support;
- assess the appropriate site subsoil class for the site in accordance with AS 1170.4-2007;
- recommend appropriate site preparation procedures including compaction criteria;
- assess the permeability of the soils at the site for potential on-site disposal of stormwater by infiltration;
- provide a subgrade California bearing ratio (CBR) value for pavement thickness design by others;
- provide recommendations for further geotechnical investigation to satisfy the needs of the design;
- assess the stability of the existing slope with respect to the foreshore works (elevated walkways, minor retaining structures);
- assess maximum loading and foundation options for structures founded on the slope (landings via piles/piers); and
- provide geotechnical design parameters for the design of SureFoot (or similar) piles.

5. FIELDWORK

Fieldwork was carried out in the presence of a representative from Galt on 1 November 2022 and comprised:

Table 2: Summary of Field Data

Type	Results Appendix	Summary	GDR Clause	Equipment Used	No. Tests	Depth Range (m)
Site Plan	Figure 1	-	-	Hand held GPS	-	-
Photographs	A	-	-	-	-	-
Cone Penetration Tests (CPTs)	B	Section 6.2	GDR3.2GDR3.2	7-tonne tracked rig	4	6.2 – 11.5
Hand Auger Boreholes (HA)	C	Section 6.2	GDR3.3	90 mm hand auger	2	1.2 – 2.0
Perth Sand Penetrometer (PSP)	D	N/A	GDR3.5GDR3.5	Hand operated PSP	12	1.2 – 4.2
Infiltration Tests (I)		Section 5.1	GDR3.7GDR3.7	Inverse auger hole	2	0.9 – 1.0

5.1. Infiltration Test Results

Table 3: Infiltration Test Results

Test Location	Depth	Material	Minimum Unsaturated Hydraulic Conductivity (k, m/day)
IT01	1.0	SAND	7.0
IT02	0.97	SAND	4.3

6. SITE CONDITIONS

6.1. Geology

Table 4: Summary of Geology Mapping

Map Sheet	Map Scale	Mapped Soils	Site Findings
Fremantle	1:50,000	LS1 – Tamala Limestone	Variable thickness of sand over limestone

6.2. Ground Model

Table 5: Summary of Units

Unit Name	Material Type	Description	Comment
A	SAND, Loose to Medium Dense	Fine to medium grained, yellow and grey brown.	Sand derived from weathering of Tamala Limestone
B	Inferred LIMESTONE	-	Inferred from refusal and outcrops

- NOTES:**
1. These units are a generalization of results from individual tests, which should be referred to for more information.
 2. Conditions at CPT locations below depth of soil sample recovery are inferred (refer to clause GDR3.2)
 3. Topsoil is not included as a discrete unit.
 4. The term limestone as used in this report is a generic term referring to carbonate rock. It does not infer a specific strength, carbonate content, grain size, etc.

The limestone surface elevation appears to vary significantly over the site. CPT testing north of the existing residence (Jutland Parade side) indicates limestone elevation varies between RL 14 m AHD (CPT01) and RL 8.5 m AHD (CPT03).

Limestone outcrops were noted in the slope towards the river. However, PSP testing indicates the outcrops are localised (possible large boulders). Testing down the slope (PSP08 to PSP10) indicates a limestone elevation of possibly around RL 1 m AHD.

Based on this, it appears that the limestone is likely present as “cliff” (i.e., from below the Swan River grading upwards towards Jutland Parade), with pinnacles and solution features. The elevation, strength, cementation and continuity is expected to vary significantly over short spatial distances. [Groundwater](#)

Table 6: Summary of Groundwater

Item	Date	Depth Range (m)	Elevation Range (m AHD)	Comment
Perth Groundwater Atlas	1997	-	RL 0	Maximum historical groundwater level coincides with Swan River level
Site Observations	Winter 2023	-	-	Not encountered
Recommended Design	-	-	RL 1	-

- NOTES:**
1. Depth range for Perth Groundwater Atlas observations based on mapped levels dating from 1997
 2. Depth range for site observations based on the site surface level at the time of investigation.

7. GEOTECHNICAL ASSESSMENT

7.1. Summary

Table 7: Summary of Geotechnical Assessment

Type	Clause	Parameter	Comment
Site Suitability	-	-	We consider the site to be geotechnically suitable for the proposed development.
Construction Methodology and Suitability	-		Shallow footings and piles in accordance with AS2870-2011 will be suitable for this site. Mass retaining will be suitable for retaining above groundwater. Stormwater disposal via infiltration is suitable.
Site Classification (AS2870)	GDR5	A	The site classification is subject to completion of the recommended site preparation. The classification not applicable to the proposed development.
Site Subsoil Class (AS1170.4)	-	Ce	
Site Preparation	GDR6	-	Site preparation (for the residence) to be done in accordance with sand over limestone sites (GDR6.2.6)
Approved Fill	GDR8	-	In situ sand will be suitable as fill, provided rubble/vegetation etc. is removed.
Compaction Control	GDR7	-	Sand can be tested with a PSP. Any rubbly/limestone fill etc. must be tested using an NDG.
Shallow Footings	GDR9	$q_{all} = 200 \text{ kPa}$	Refer Section 7.3
Piles	GDR10	-	Piling will be suitable, but allowance must be made for variable ground conditions. This is discussed in Section 7.4.
Earth Pressure Coefficients	GDR11	GDR3.4	
Unsaturated Hydraulic Conductivity	GDR13	$K_{unsat} = 4 \text{ m/day}$	
Pavement Subgrade CBR	GDR16	CBR = 12%	

NOTES: 1. q_{all} – allowable bearing pressure (maximum for all footings, refer to footing tables for further details)

7.2. Geotechnical Model

Table 8: Summary of Units

Unit Name	γ_{bulk} (kN/m ³)	ϕ' (°)	c' (kPa)	S_u (kPa)	E_v (MPa)	ν
A	17	33	-	-	20	0.3
B	19	37	2	-	50	0.25

NOTES:

- γ_{bulk} – bulk unit weight
- ϕ' – bulk unit weight
- S_u – undrained shear strength
- c' – effective cohesion
- E_v – vertical elastic modulus
- ν – Poisson's Ratio

7.3. Shallow Footings

Shallow footing parameters are provided for the residence, with the footings assumed to be founded at around RL 13 m to RL 14 m AHD.

Table 9: Isolated Pad Footing Allowable Bearing Pressures and Estimated Settlements

d_e (m)	b (m)	q_{all} (kPa)	s (mm)
0.5	0.5	150	5-10
0.5	1.0	175	5-10
0.5	1.5	200	10-15
0.5	2.0	200	15-20
1.0	1.0	200	5-10
1.0	2.0	200	15-20
1.0	3.0	200	20-25

NOTES:

1. d_e – minimum embedment depth (below finished ground level or floor slab)
2. b – Footing breadth (footings assumed approximately square)
3. q_{all} – allowable bearing pressure (peak). Limited to keep estimated settlements less than 25 mm. Higher q_{all} may be possible if higher settlements can be tolerated – refer queries to us.
4. s – estimated settlement (excludes shrink/swell from site class)
5. Refer to GDR9

Table 10: Isolated Strip Footing Allowable Bearing Pressures and Estimated Settlements

d_e (m)	b (m)	q_{all} (kPa)	s (mm)
0.5	0.5	130	5-10
0.5	1.0	175	15-20
0.5	1.5	175	20-25
0.5	2.0	130	20-25
1.0	1.0	200	20-25
1.0	2.0	130	20-25
1.0	3.0	75	20-25

- NOTES:**
- d_e – minimum embedment depth (below finished ground level or floor slab)
 - b – Footing breadth (footings assumed long relative to breadth)
 - q_{all} – allowable bearing pressure (peak). Limited to keep estimated settlements less than 25 mm. Higher q_{all} may be possible if higher settlements can be tolerated – refer queries to us.
 - s – estimated settlement (excludes shrink/swell from site class)
 - Refer to GDR9

7.4. Piled Foundations

Due to the relatively low allowable bearing pressures, we expect that piling will be required for the house and any retaining walls. Continuous flight auger (CFA) piles would be suited to this site, however, other pile types may be considered.

Given that the limestone elevation is inconsistent, and the continuity/strength is unknown, we consider that the preliminary design should be done assuming only medium-dense sand. Further investigation involving drilling and recovery of deep limestone must be done prior to piling.

The upper 2 m or 1.5 x pile diameter (whichever is deeper) should be ignored in capacity design. We recommend designing the piles as friction piles only unless the limestone elevation, strength and consistency are thoroughly investigated.

Table 11: Pile Design Parameters – CFA Piles

Unit Name	γ_{bulk} (kN/m ³)	$\phi^?$ (°)	Unit Base Resistance (kPa)	Unit Shaft Resistance (kPa)
A	17	34	1,000 (refer comment above, friction pile design is recommended)	60

7.5. Riverbank (Slope) Works

A survey was undertaken along the riverbank by MNG Survey. Digital copies of the survey were provided to us to assist in our assessment.

7.5.1. Slope Stability

We carried out a slope stability assessment of the existing slope using Slide2 by Rocscience. The analysis was carried out using:

- the survey provided by MNG;
- the soil parameters as described in Section 7.2; and
- the Morgenstern-Price/ general limit equilibrium method of analysis.

The following sections were analysed:

- Two sections at the east and west, with the west being the steepest section of the slope.
- A section along the existing staircase alignment – understood to be the proposed alignment of any future structures.

Our analysis indicates the following:

- The slope is very steep at the east and west, with analytical factors of safety (FoS) of between around 0.7 and 1.0. Clearly this low FoS is not the case as historical aerial imagery since ~1950 indicates no significant change or slip failures – this is likely a result of analytical assumptions around the limestone surface elevation and the impact of vegetation.
- The staircase alignment is generally flatter with FoS of between 1.0 and 1.2 (typical).
- The typical design minimum for engineered slopes in the permanent case is 1.5. Therefore, the slope is less stable than an engineered slope.
- By supporting the proposed slope structures on piles below possible failure surfaces, the risks to these structures can be reduced.

We consider that the slope is “metastable”, and slope movements likely occur as very gradual creep of the upper 1 m to 2 m of the surficial sands. This does not preclude larger-scale slope failures (which are possible). The best way to stabilise the upper surfaces of the slope is to maintain and encourage vegetation, given that the binding action of tree roots helps to maintain the stability of the upper surface. We recommend against removal of any vegetation on the slope (where possible), and in particular any vegetation with significant root systems.

7.5.2. Foundations

We understand that the access to the Swan River is proposed using a structure that will likely be founded using a combination of shallow piles and/or SureFoot anchored foundations. Given the highly variable site conditions, we recommend capacity design of all piles/foundations assuming that only loose to medium-dense sand is present (design parameters in Section 7.2). The upper 1 m should be ignored as this zone will be the most likely to “creep”.

Where possible, all piles and anchors should be installed into the limestone. Shallow foundations or other ground-bearing foundations must not be used on the slope.

Based on the results of our slope stability analysis, the maximum depth of failure surfaces with FoS <1.5 is about 3 m. On this basis, piles or anchors for the structures on the proposed access must be installed to:

- a minimum 3 m depth from the current slope level; or
- at least 0.5 m into competent limestone.

If anchors are only installed into sandy soils, we recommend grouting the anchors or installation into a cement-stabilised backfill.

7.5.3. Construction Considerations

Stormwater must not be disposed onto the slope (i.e. all stormwater run-off must be directed away from the slope). This will reduce the risk of erosion and loss of sand along the slope.

If small-scale slips or loss of surface occur, we recommend backfilling these with cement-stabilised sand. Ideally, this would extend to the top of the limestone in the area to the previous surface. Cement-stabilised sand would increase the factor of safety significantly but will prevent future regrowth of vegetation.

Alternatively, slope vegetation matting (i.e., Jute Mat/Mesh or Grassroots) could be used to stabilise the slope and encourage re-vegetation. A geotechnical engineer must be consulted if any slope failures are encountered.

7.6. Construction Recommendations (Residence)

Arched Retaining Structure Foundations

We attempted to verify the founding conditions of the arched retaining structure by digging to expose the footing. We were unable to verify the founding conditions of the structure, but for long-term founding stability, the structure should be:

- Founded on in-situ limestone; or
- Be grouted between the zone below the structure to the top of limestone.

The builder or otherwise should verify the founding conditions along the structure by digging to expose the footings and confirm whether it is in contact with limestone.

Note that retaining structure is supported by dead-man anchors. The anchors must not be removed / damaged until all backfill material behind the wall has been removed and there are no lateral loads acting on the wall.

Stormwater Disposal

In order to improve long-term performance and stability, all stormwater must be directed away from the slope and retaining structure. Disposal can be done on site into soakwells, preferably towards Jutland Parade, and at least 1V:2H from any basement walls, and at least 500 mm above any limestone level.

Soakwells should be at least 10 m from the top of the slope to reduce the risk of concentrated flow and erosion of the loose surficial sand on the slope.

7.7. Future Investigations

Future investigations are required to facilitate the following:

- Pile designs – diamond core drilling at locations of proposed piles/pile retaining walls is required to facilitate understanding of limestone elevation, strength and consistency. This will improve design efficiency of piles and reduce construction risks.
- Arched retaining structure – investigation of founding conditions (i.e., by exposing the footings) is recommended to ensure that the structure is in contact with competent limestone. Permeation grouting of any sandy zone below the footing is recommended where this is not the case.
- Inspections during construction of slope structure – a geotechnical engineer should assess conditions (for anchors/piles) during construction of the structure on the slope.

8. CLOSURE

GALT GEOTECHNICS

A handwritten signature in black ink, appearing to read "Sean Coffey".

Sean Coffey CPEng
Geotechnical Engineer

[https://galtgeo.sharepoint.com/sites/wag230419/shared documents/01 jba si jutland pde/03 correspondence/wag230419-01 001 r rev0.docx](https://galtgeo.sharepoint.com/sites/wag230419/shared%20documents/01%20jba%20si%20jutland%20pde/03%20correspondence/wag230419-01%20001%20r%20rev0.docx)

Figures

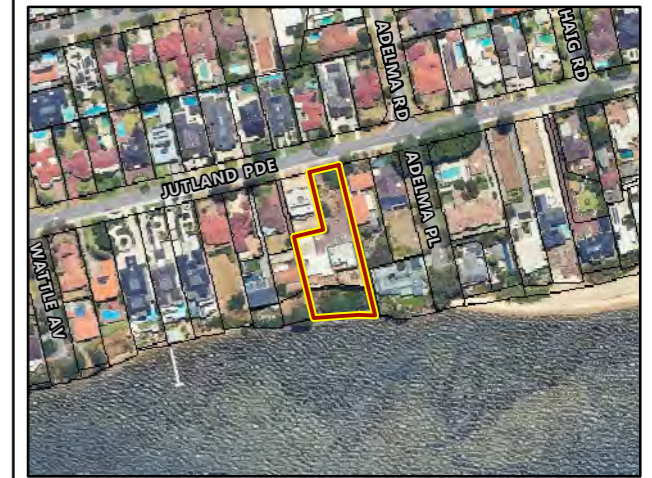

Legend

- Site Boundary
- ▼ Cone Penetration Test
- ◆ Hand Auger Borehole / Perth Sand Penetrometer / Infiltration Test
- Perth Sand Penetrometer

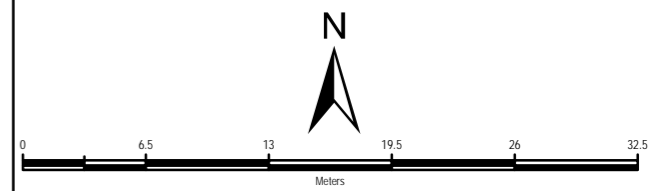

NOTES
Aerial Imagery and Cadastre sourced from Landgate/SLIP



SCALE	1:400	(A3)
DRAWN	DAC	
DATE DRAWN	11/09/2023	
CHECKED	AM	
DATE CHECKED	11/09/2023	
PROJECTION	GDA 1994 MGA Zone 50	

Galt Geotechnics Pty Ltd
 ACN : 138 490 865
 Tel : +61 (0)8 6272-0200
 Address : 50 Edward Street
 Osborne Park WA 6017

COPYRIGHT © 2023 THIS FIGURE AND ITS CONTENTS REMAINS THE PROPERTY OF GALT GEOTECHNICS PTY LTD AND MAY NOT BE REPRODUCED WITHOUT PRIOR APPROVAL. THIS FIGURE SHOULD BE READ IN CONJUNCTION WITH THE ACCOMPANYING REPORT.

CLIENT	JOSH BYRNE & ASSOCIATES		
PROJECT	PROPOSED 4-STOREY BUILDING		
LOCATION	26 JUTLAND PARADE DALKEITH		
TITLE	SITE & LOCATION PLAN		
Job No	WAG230419-01	Fig No	FIGURE 1
			Rev A

Appendices

Appendix A: Site Photographs



Photograph 1: CPT testing at the residence level



Photograph 1: Typical slope vegetation



Photograph 2: Masonry steps along the slope

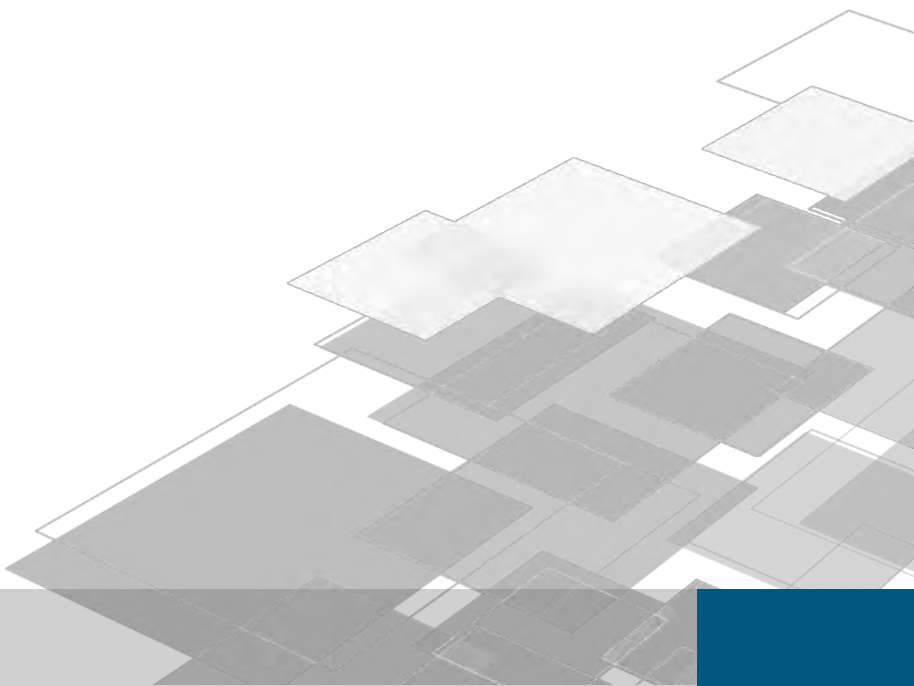

Photograph 3: Arched retaining structure



Photograph 4: Looking west at the rear of the residence



Photograph 5: Looking west towards the Swan River from the residence level



Photograph 6: Limestone outcrop (possibly boulders) along the slope



Appendix B: Cone Penetration Test Results



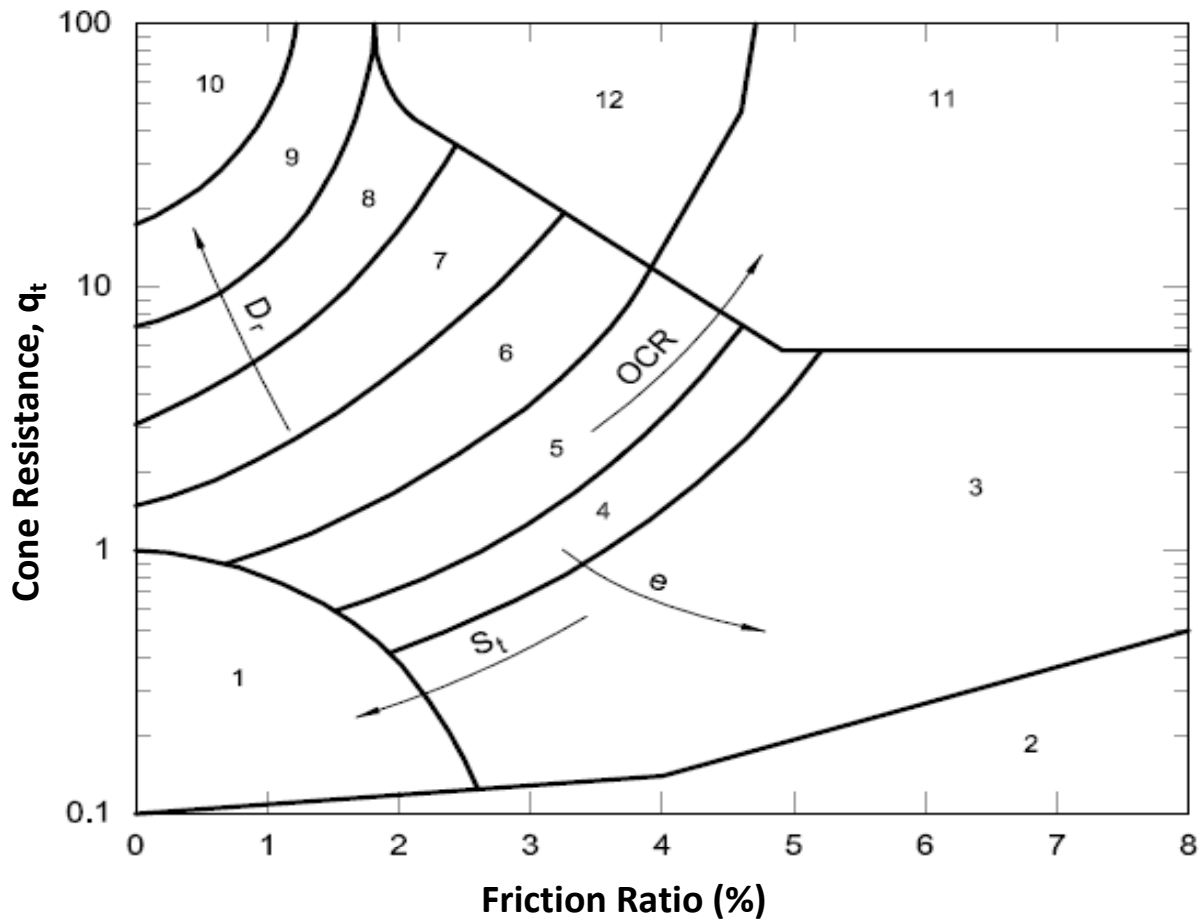

DEFINITIONS

- q_t : Cone tip resistance corrected for pore water pressure
- S_t : Sensitivity
- e : Void ratio
- D_r : Relative density
- OCR : Overconsolidation ratio
- OC : Overconsolidated

SOIL BEHAVIOUR TYPE ZONES

- | | |
|------------------------------|--|
| 1. Sensitive fine grained | 7. Silty sand to sandy silt |
| 2. Organic material | 8. Sand to silty sand |
| 3. Clay | 9. Sand |
| 4. Silty clay to clay | 10. Gravelly sand to sand |
| 5. Clayey silt to silty clay | 11. Very stiff fine grained material (OC/cemented) |
| 6. Sandy silt to clayey silt | 12. Sand to clayey sand (OC/cemented) |

NOTES

- A. Some overlap in type zones is expected
- B. Local correlations are preferred and may indicate soil type boundaries that are different from those shown above

Reference: Robertson, P.K., Campanella, R.G., Gillespie, D. and Grieg, J. (1986) "Use of Piezometer Cone Data". Proceedings of the ASCE Speciality Conference In Situ '86: Use of In Situ Tests in Geotechnical Engineering, Blacksburg, pp 1263-80, American Society of Civil Engineers (ASCE)



CONE PENETRATION TESTING (CPT) SOIL TYPE INTERPRETATION

ELECTRIC FRICTION-CONE PENETROMETER

CLIENT: GALT in support of Josh Byrne and Associates

Job No.: WAG230419-01

PROJECT: Dalkeith Development

Date/s: 4-Sep-2023

LOCATION: 26 Jutland Parade, Dalkeith

ALL DATA

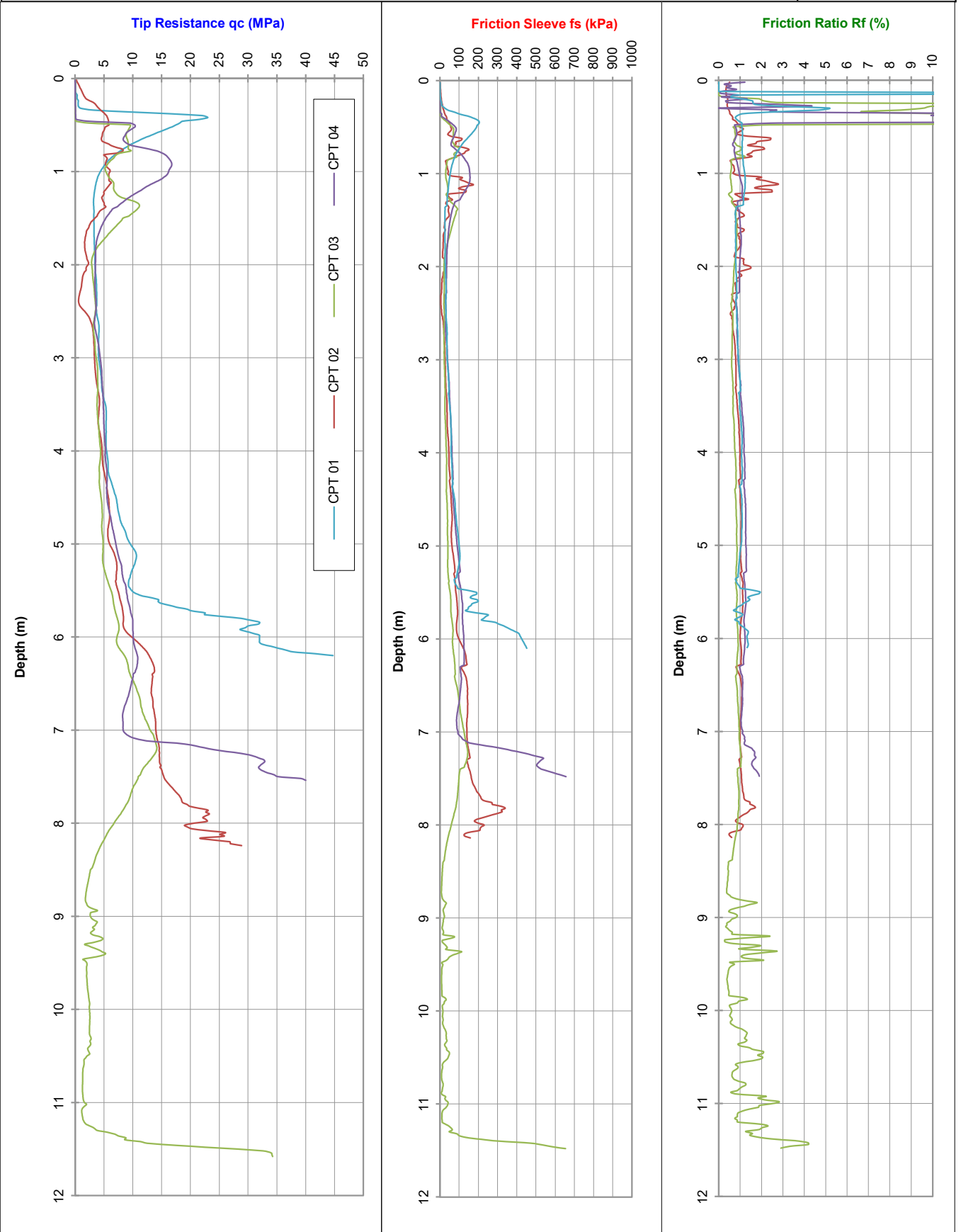

ELECTRIC FRICTION-CONE PENETROMETER

Probe I.D

CLIENT: GALT in support of Josh Byrne and Associates

Job No.: WAG230419-01

PROJECT: Dalkeith Development

RL (m):

CPT 01

LOCATION: 26 Jutland Parade, Dalkeith

Co-ords:

04-Sep-23

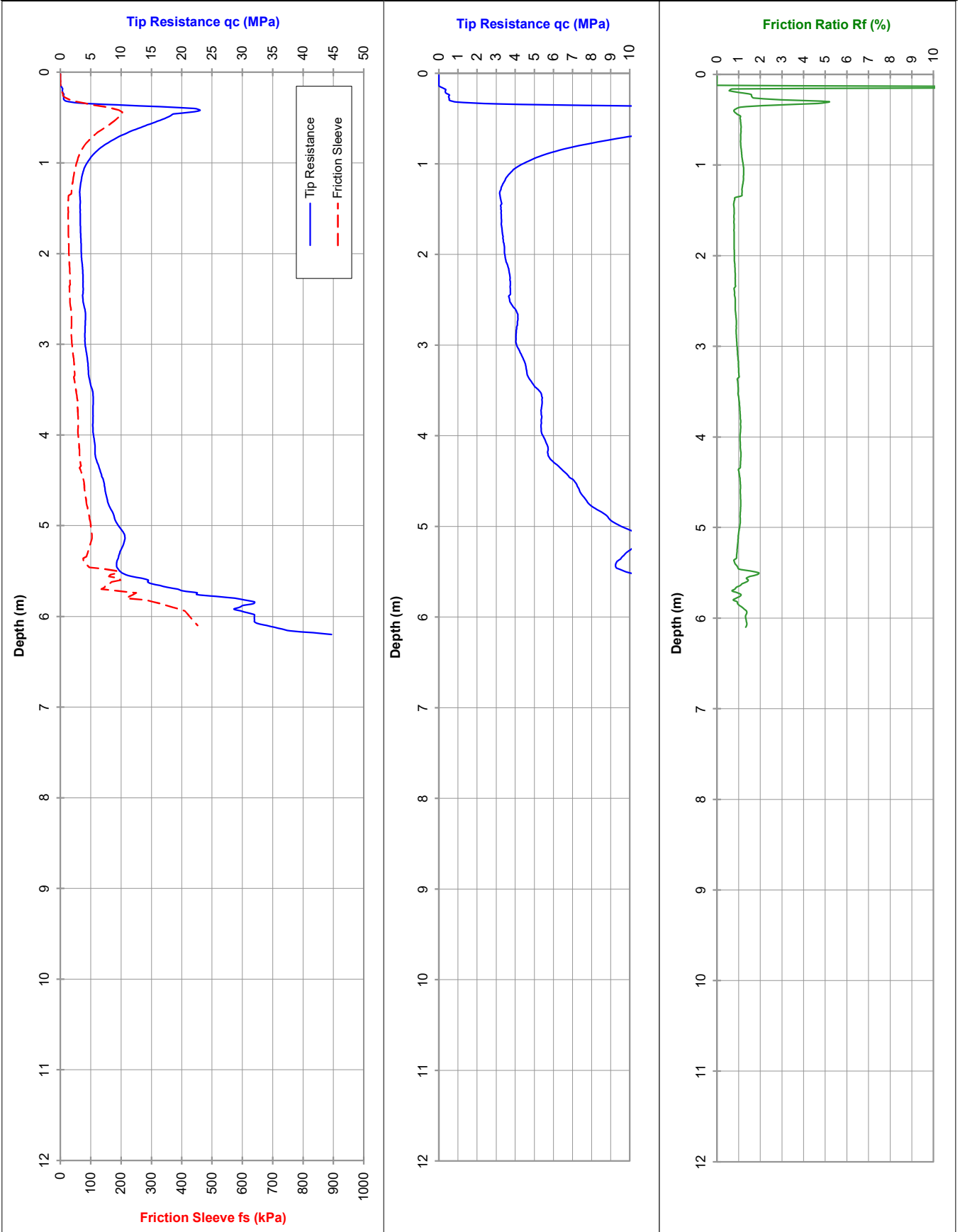

Tested in accordance with AS 1289.6.5.1-1999 and IRTP 2001 for friction reducer

Approx. water (m): -

Dummy probe to (m): 0.4

Refusal: Inclination

Cone I.D.: EC27

File: GL1150T

Rig Type: 7t track

ELECTRIC FRICTION-CONE PENETROMETER

Probe I.D

CLIENT: GALT in support of Josh Byrne and Associates

Job No.: WAG230419-01

PROJECT: Dalkeith Development

RL (m):

CPT 02

LOCATION: 26 Jutland Parade, Dalkeith

Co-ords:

04-Sep-23

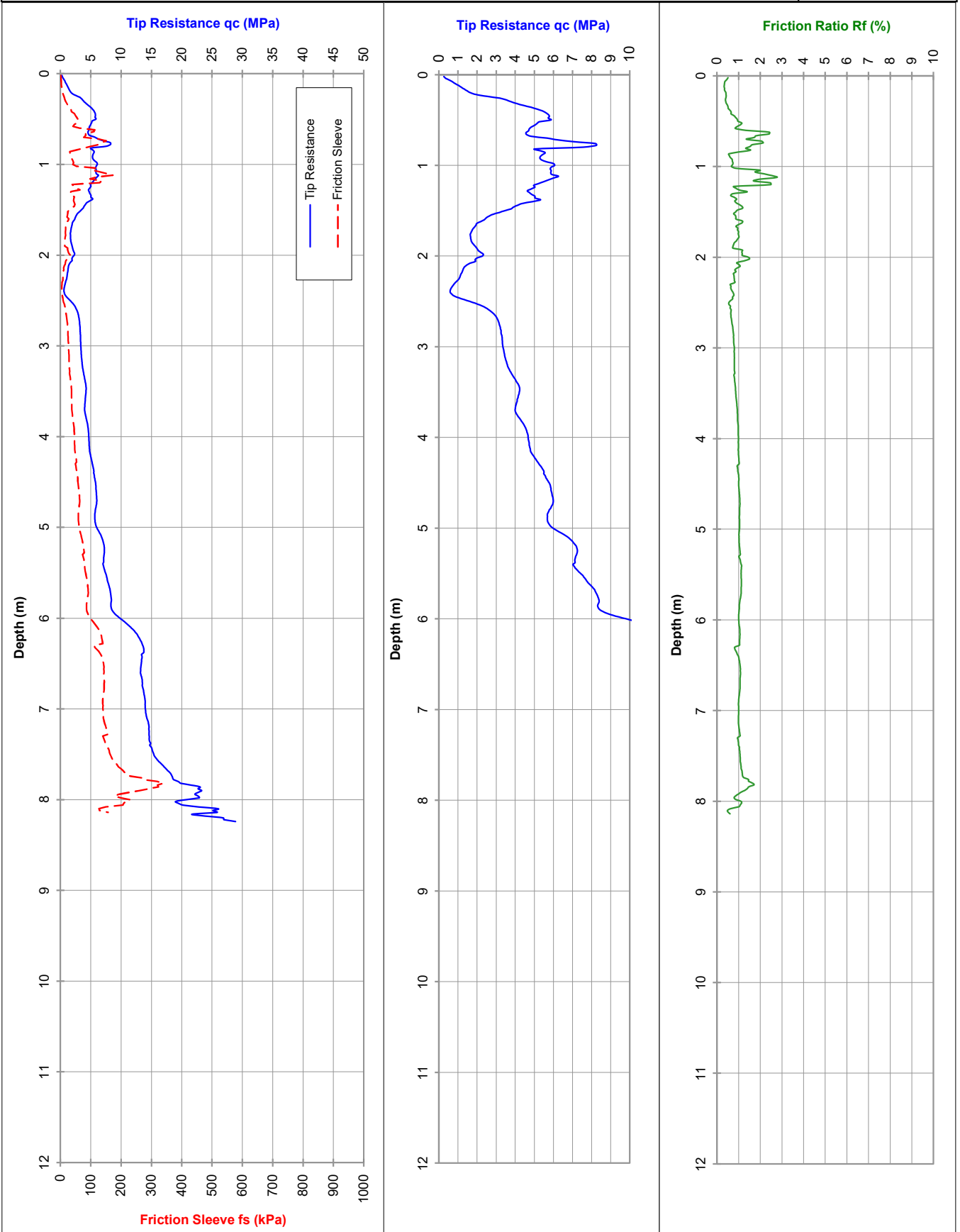

Tested in accordance with AS 1289.6.5.1-1999 and IRTF 2001 for friction reducer

Approx. water (m): Dry to 8.2

Dummy probe to (m):

Refusal: Inclination

Cone I.D.: EC27

File: GL1147T

Rig Type: 7t track

ELECTRIC FRICTION-CONE PENETROMETER

Probe I.D

CLIENT: GALT in support of Josh Byrne and Associates

Job No.: WAG230419-01

PROJECT: Dalkeith Development

RL (m):

CPT 03

LOCATION: 26 Jutland Parade, Dalkeith

Co-ords:

04-Sep-23

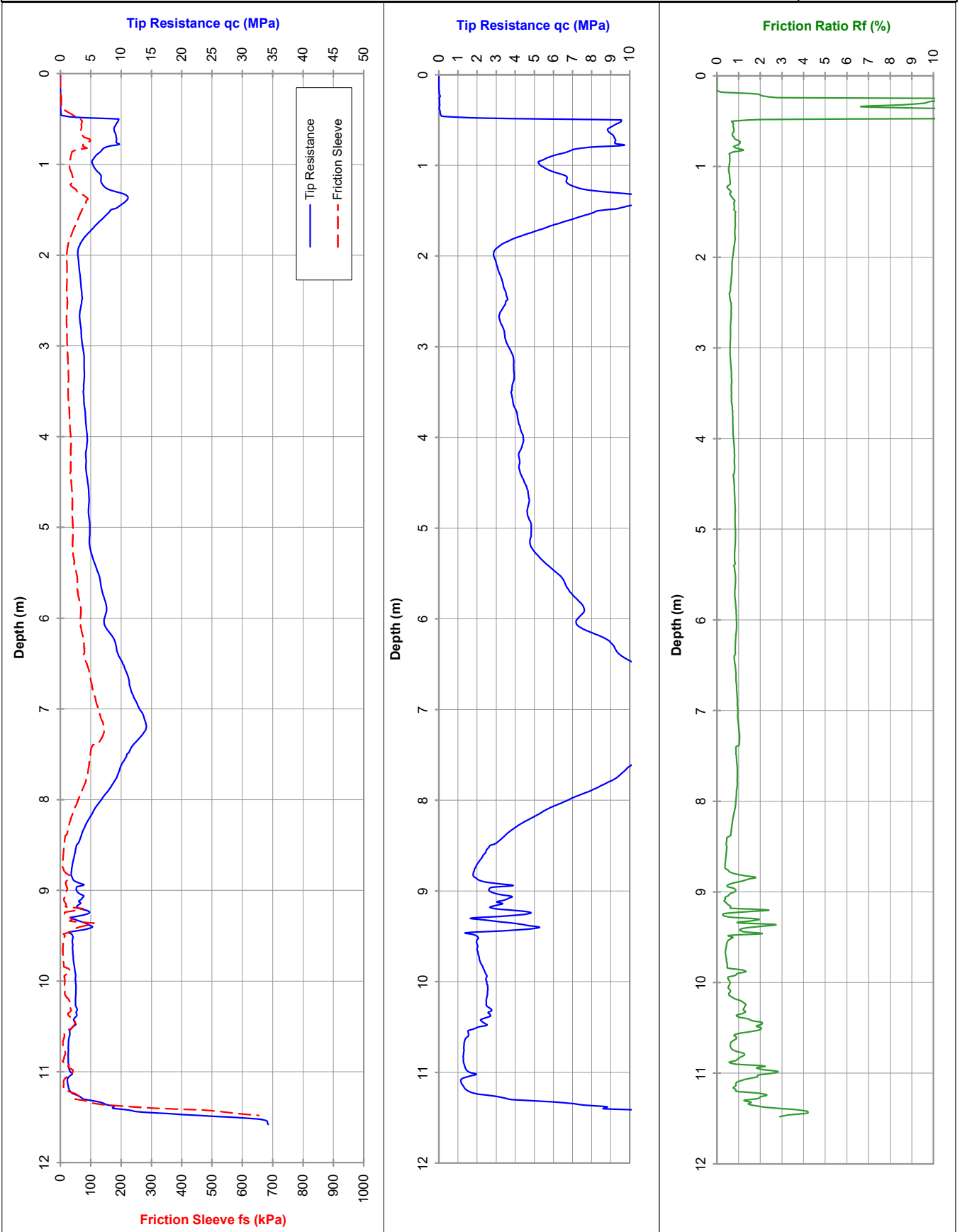

Tested in accordance with AS 1289.6.5.1-1999 and IRTP 2001 for friction reducer

Approx. water (m): Dry to 11.5

Dummy probe to (m): 0.5

Refusal: Inclination

Cone I.D.: EC27

File: GL1148T

Rig Type: 7t track

ELECTRIC FRICTION-CONE PENETROMETER

Probe I.D

CLIENT: GALT in support of Josh Byrne and Associates

Job No.: WAG230419-01

PROJECT: Dalkeith Development

RL (m):

CPT 04

LOCATION: 26 Jutland Parade, Dalkeith

Co-ords:

04-Sep-23

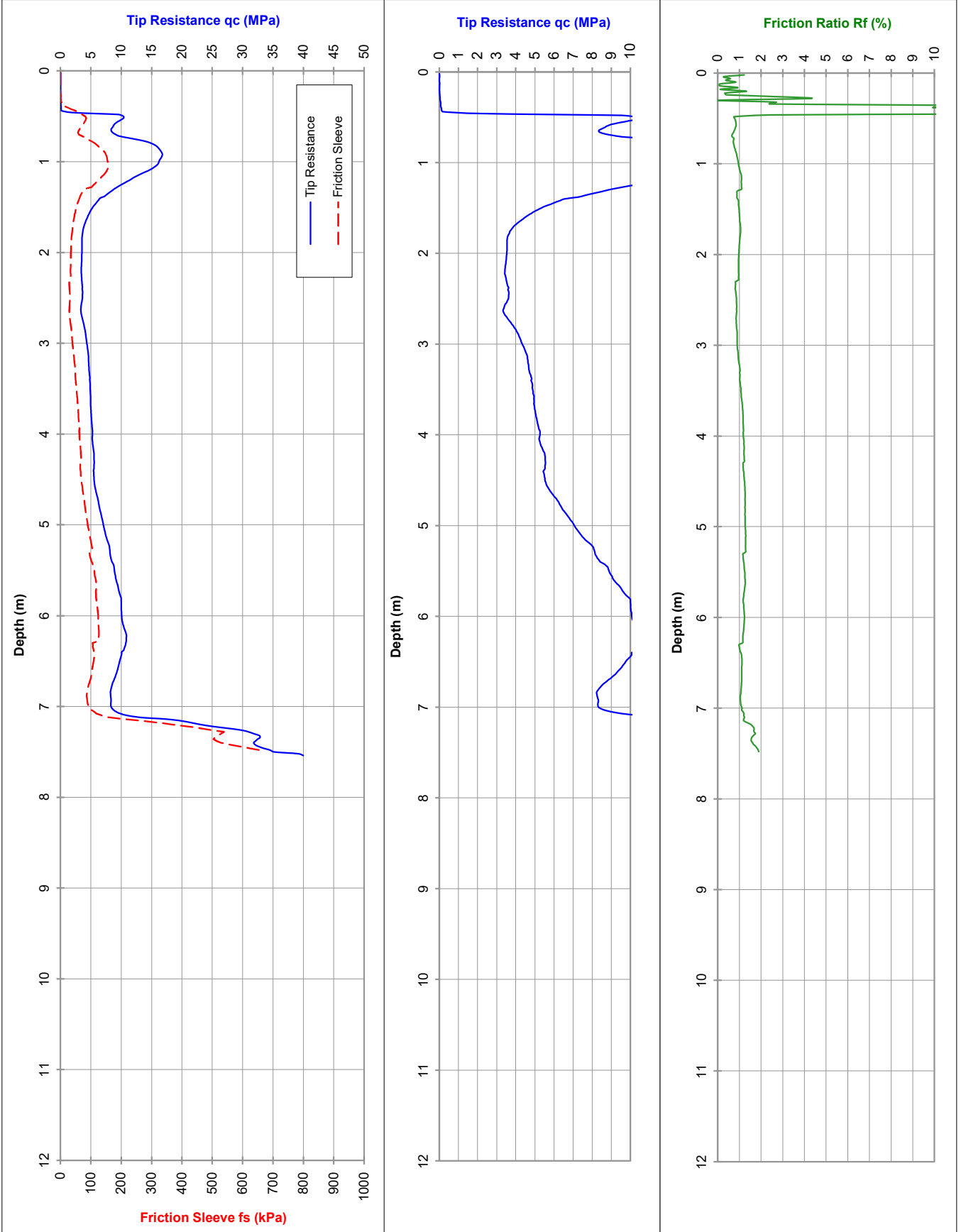

Tested in accordance with AS 1289.6.5.1-1999 and IRTF 2001 for friction reducer

Approx. water (m): Dry to 7.5

Dummy probe to (m): 0.5

Refusal: 40 MPa + Rod Friction

Cone I.D.: EC27

File: GL1149T

Rig Type: 7t track

Appendix C: Borehole Reports

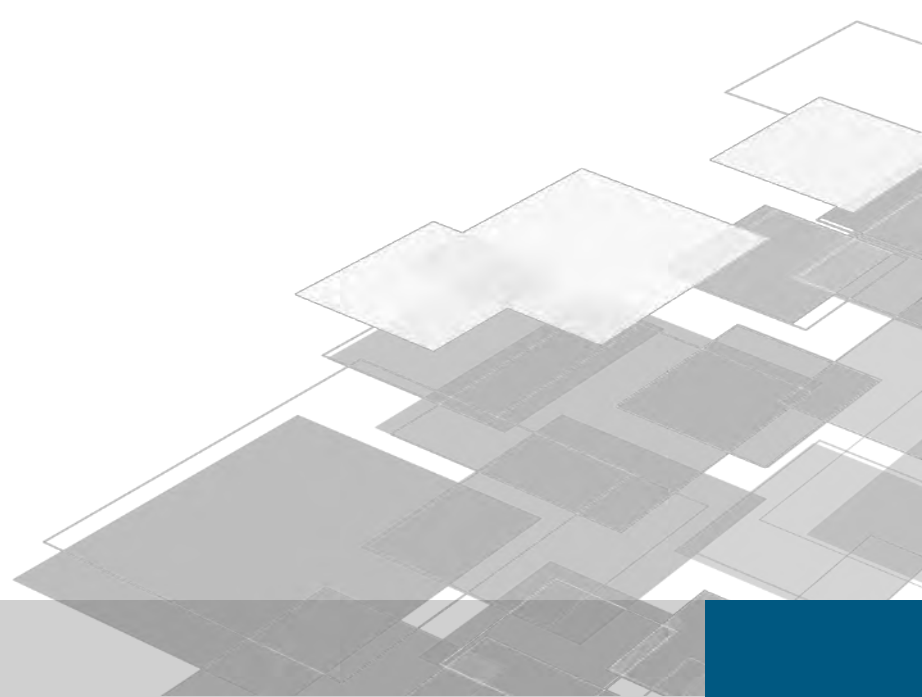

METHOD OF SOIL DESCRIPTION BOREHOLE AND TEST PIT REPORTS



GRAPHIC LOG & SOIL CLASSIFICATION SYMBOLS

Graphic	USCS	Soil Name
		FILL (various types)
		COBBLES / BOULDERS
	GP	GRAVEL (poorly graded)
	GW	GRAVEL (well graded)
	GC	Clayey GRAVEL
	GM	Silty GRAVEL
	SP	SAND (poorly graded)
	SW	SAND (well graded)
	SC	Clayey SAND

Graphic	USCS	Soil Name
	SM	Silty SAND
	ML	SILT (low liquid limit)
	MH	SILT (high liquid limit)
	CL	CLAY (low plasticity)
	CI	CLAY (medium plasticity)
	CH	CLAY (high plasticity)
	OL	Organic SILT (low liquid limit)
	OH	Organic SILT (high liquid limit)
	Pt	PEAT

NOTE: Dual classification given for soils with a fines content between 5% and 12%.

SOIL CLASSIFICATION AND INFERRED STRATIGRAPHY

Soil descriptions are based on AS1726-2017. Material properties are assessed in the field by visual/tactile methods in combination with field and laboratory testing techniques (where used).

NOTE: AS 1726-2017 defines a fine grained soil where the total dry mass of fine fractions (<0.075 mm particle size) exceeds 35%.

PARTICLE SIZE		
Soil Name	Particle Size (mm)	
BOULDERS	>200	
COBBLES	63 to 200	
GRAVEL	Coarse	19 to 63
	Medium	6.7 to 19
	Fine	2.3 to 6.7
SAND	Coarse	0.6 to 2.36
	Medium	0.21 to 0.6
	Fine	0.075 to 0.21
FINES	SILT	0.002 to 0.075
	CLAY	<0.002

PLASTICITY - MODIFIED CASAGRANDE CHART - AS1726-2017

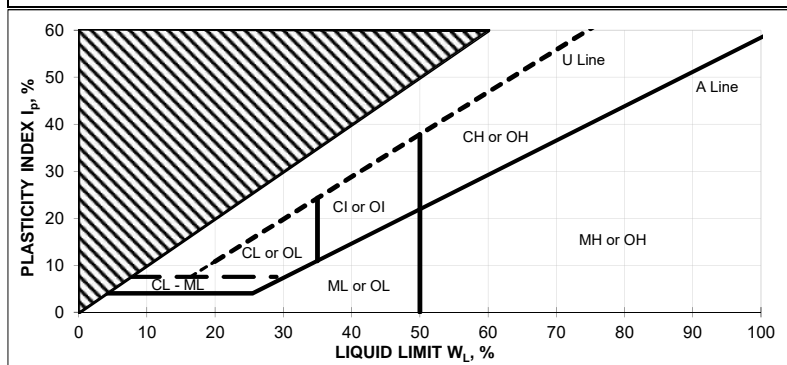

RESISTANCE TO EXCAVATION		
Symbol	Term	Description
VE	Very easy	All resistances are relative to the selected method of excavation
E	Easy	
F	Firm	
H	Hard	
VH	Very hard	

MOISTURE CONDITION	
Symbol	Term
D	Dry
M	Moist
W	Wet

CEMENTATION	
Cementation	Description
Weakly cemented	Soil may be easily disaggregated by hand in air or water
Moderately cemented	Effort is required to disaggregate the soil by hand in air or water

CONSISTENCY		
Symbol	Term	Undrained Shear Strength (kPa)
VS	Very Soft	0 to 12
S	Soft	12 to 25
F	Firm	25 to 50
St	Stiff	50 to 100
VSt	Very Stiff	100 to 200
H	Hard	>200

ORGANIC SOILS	
Material	Organic Content % of dry mass
Inorganic soil	<2%
Organic soil	2% to 25%
Peat	>25%

DENSITY		
Symbol	Term	Density Index (%)
VL	Very Loose	<15
L	Loose	15 to 35
MD	Medium Dense	35 to 65
D	Dense	65 to 85
VD	Very Dense	>85

EXPLANATORY NOTES TO BE READ WITH BOREHOLE AND TEST PIT REPORTS



METHOD OF DRILLING OR EXCAVATION

AC	Air Core	E	Excavator	PQ3	PQ3 Core Barrel
AD/T	Auger Drilling with TC-Bit	EH	Excavator with Hammer	PT	Push Tube
AD/V	Auger Drilling with V-Bit	HA	Hand Auger	R	Ripper
AT	Air Track	HMLC	HMLC Core Barrel	RR	Rock Roller
B	Bulldozer Blade	HQ3	HQ3 Core Barrel	SON	Sonic Rig
BH	Backhoe Bucket	N	Natural Exposure	SPT	Driven SPT
CT	Cable Tool	NMLC	NMLC Core Barrel	WB	Washbore
DT	Diatube	PP	Push Probe	X	Existing Excavation

SUPPORT

T Timbering

PENETRATION EFFORT (RELATIVE TO THE EQUIPMENT USED)

VE	Very Easy	E	Easy	F	Firm
H	Hard	VH	Very Hard		

WATER

▶	Water Inflow	▼	Water Level
◀	Water Loss (complete)		
◁	Water Loss (partial)		

SAMPLING AND TESTING

B	Bulk Disturbed Sample	P	Piston Sample
BLK	Block Sample	PBT	Plate Bearing Test
C	Core Sample	U	Undisturbed Push-in Sample
CBR	CBR Mould Sample		U50: 50 mm diameter
D	Small Disturbed Sample	SPT	Standard Penetration Test
ES	Environmental Soil Sample		Example: 3, 4, 5 N=9
EW	Environmental Water Sample		3,4,5: Blows per 150 mm
G	Gas Sample		N=9: Blows per 300 mm after
HP	Hand Penetrometer		150 mm seating interval
LB	Large Bulk Disturbed Sample	VS	Vane Shear; P = Peak
M	Mazier Type Sample		R = Remoulded (kPa)
MC	Moisture Content Sample	W	Water Sample

ROCK CORE RECOVERY

$$TCR = \text{Total Core Recovery (\%)} = \frac{CRL}{TCL} \times 100$$

$$RQD = \text{Rock Quality Designation (\%)} = \frac{ALC > 100}{TCL} \times 100$$

TCL Length of Core Run

CRL Length of Core Recovered

ALC>100 Total Length of Axial Lengths of Core Greater than 100 mm Long

Job No : WAG230419-01

Easting : 0.0

Sheet : 1 OF 1

Client : Josh Byrne & Associates

Northing : 0.0

Logged : AM

Project : Proposed 4-Storey Building

UTM :

Logged Date : 04/09/2023

Location : 26 Jutland Parade, Dalkeith WA

Drill Rig : Hand Auger

Checked :

Contractor : Galt Geotechnics

Inclination : -90 deg

Checked Date : 10/09/2023

Excavation Resistance	PSP	Depth (m)	Soil Origin	Graphic Log	Classification Code	Material Description	Moisture	Consistency/Density	Remarks
									General Remarks
	SET	0.06			PAR	Pavers			Log Density inferred from Perth Sand Penetrometer (PSP) test adjacent borehole
		0.15	Fill		SP	Fill SAND: dark grey, loose, fine to medium grained, trace fine to medium sized gravel, (trace fines, trace organic fines and rootlets).	D	L	
	1		Fill		SP	Fill SAND: pale grey, dense, fine to medium grained, trace fine to medium sized gravel, (trace fines, possible fill to around 1 m depth).		D	
	1								
	4								
	5								
		0.7							
	9		Natural		SP	Natural SAND: yellow, fine to medium grained, (trace fines).	M-D		
	6								
	5								
	4								
	3								
	4								
	4								
	5								
	4								
		2				HA01 Terminated at 2 m (Target Depth. Groundwater not encountered)			
	5								
	2								
	4								
	4								
	4								
	5								
	4								
		3							
	4								



REPORT OF BOREHOLE: HA02

Job No : WAG230419-01

Easting : 0

Sheet : 1 OF 1

Client : Josh Byrne & Associates

Northing : 0

Logged : AM

Project : Proposed 4-Storey Building

UTM :

Logged Date : 04/09/2023

Location : 26 Jutland Parade, Dalkeith WA

Drill Rig : Hand Auger

Checked :

Contractor : Galt Geotechnics

Inclination : -90 deg

Checked Date : 10/09/2023

Excavation Resistance	PSP	Depth (m)	Soil Origin	Graphic Log	Classification Code	Material Description	Moisture	Consistency/Density	Remarks				
									General Remarks	Sample			
	SET		Fill		SP	Fill SAND: pale yellow brown, loose, fine to medium grained, trace fine to medium sized gravel, (trace fines).	D	L	Density inferred from Perth Sand Penetrometer (PSP) test adjacent borehole				
	1												
	1												
	2	0.45	Fill		SP						As above, dense.	M-D	D
	2												
	6												
	6												
	2	1											
	5					HA02 refusal at 1.2 m (Refusal on unknown obstruction. Groundwater not encountered.)							
	13												
	16												
	11												
	9												
	6	2											
		3											

Appendix D: Perth Sand Penetrometer Test Results

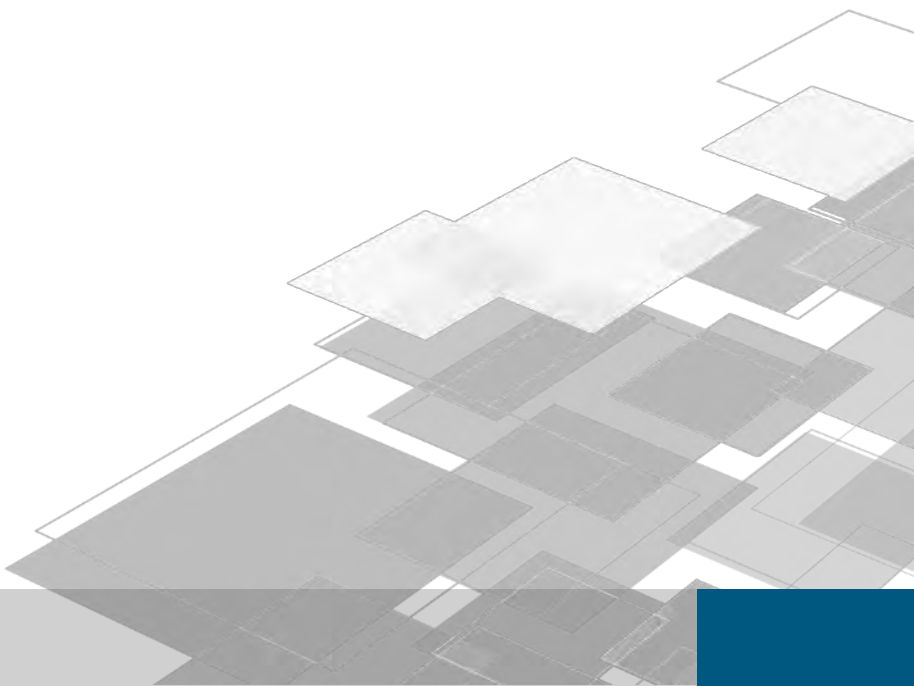

PERTH SAND PENETROMETER FIELD TEST DATA
(AS 1289.6.3.3)

Client: Josh Byrne & Associates
Project: Proposed 4-Storey Building
Location: 26 Jutland Parade, Nedlands

Job No: WAG230419-01
Date: 4-Sep-23
Engineer: AM



Test No:	PSP01	PSP02	PSP03	PSP04	PSP05	PSP06	PSP07	PSP08
Location:	HA01	HA02	refer to Figure 1 - Site and Location Plan					
Depth (mm)	N ^o of Penetrometer Blows per 150 mm Depth Interval							
0-150	SET	SET	SET	SET	SET	SET	SET	SET
150-300	1	1	1	0	0	0	0	0
300-450	1	1	1	1	0	0	0	0
450-600	4	2	1	0	0	0	0	1
600-750	5	2	1	1	1	1	0	2
750-900	9	6	0	1	1	0	0	1
900-1050	6	6	1	1	0	2	1	1
1050-1200	5	2	0	1	1	2	1	2
1200-1350	4	5	1	1	1	2	4	2
1350-1500	3	13	1	1	1	2	3	1
1500-1650	4	16	1	1	2	2	5	3
1650-1800	4	11	4	2	4	1	6	3
1800-1950	5	9	2	1	5	3	8	5
1950-2100	4	6	2	2	4	2	5	5
2100-2250	5		1	2	4	2	4	4
2250-2400	2		1	2	4	2	3	3
2400-2550	4		2	2	4	2	4	3
2550-2700	4		3	3	4	3	3	3
2700-2850	4		3	3	4	2	4	5
2850-3000	5		2	4	5	3	4	8
3000-3150	4		4	3	5	5	3	4
3150-3300			3	3	3	4	4	7
3300-3450			4	3	5	4	4	8
3450-3600			7	4	5	6 HB	5	5
3600-3750			6	4	4		5	4
3750-3900			6	5	6		7	6
3900-4050			6	6	7		6	9
4050-4200			6	6	6		7	9
4200-4350								
4350-4500								
4500-4650								
4650-4800								
4800-4950								
4950-5100								

Perth Sand Penetrometer tests done in accordance with AS 1289.6.3.3 (except blow counts are reported per 150 mm, rather than 300 mm)
 0 = Penetration due to hammer weight only
 R: Refusal



Standard
Geotechnical
Definitions,
Recommendations,
Requirements and
Limitations

GDR1. ABOUT THIS APPENDIX

These technical notes are to be read with the attached report. These notes contain important information regarding the study in the attached report, and the report cannot be considered in isolation without full reading of these notes.

Where there are conflicts between this appendix and the report text, the report text takes precedence.

Unless noted otherwise, geotechnical investigations are conducted in accordance with AS1726-2017, "Geotechnical site investigations".

Unless noted otherwise, the report does not include any assessment (or implied assessment) of karst risk.

GDR2. DEFINITIONS

The following definitions apply:

- **Approved Fill** – fill that has been assessed and approved by the geotechnical engineer or civil designer for a particular purpose.
- **Bulk Fill** – Controlled fill intended to support future infrastructure, but potentially lacking some engineering properties required for upper fill layers or adjacent to structures, where fill with specific properties may be required. Contrast with Select Fill.
- **Civil Design** – the engineering design of the earthworks including surface water and erosion control and subsurface drainage control (where required) to achieve an earthworked, drained site which is capable of supporting the proposed development (including target site classification to AS2870, where relevant). This design is separate to this geotechnical investigation and is a required element of a site development.
- **Clay** – A component of a soil with particles smaller than 0.002 mm in size.
- **Cohesionless (Non-cohesive) Soil** – A soil mass that has does not hold together at low applied stress levels. The strength of the soil depends solely on friction between particles.
- **Cohesive Soil** – A soil mass that has holds together and can adhere to itself.
- **Collapsible Soil** – a soil with high void ratio that is typically strong when dry but loses strength and consolidates under constant stress when wetted, usually due to loss of soil matric suction or dissolving of a chemical cementing agent.
- **Compaction** – The process of increasing the soil density, typically be mechanical means.
- **Competent Person** – A person who has, through a combination of training, education and experience, acquired knowledge and skills enabling that person to correctly perform a specified task.
- **Consistency** – The stiffness of a cohesive soil, at specific moisture contents, to resist mechanical stress or manipulation (remoulding).
- **Controlled (or engineered) Fill** – Any fill for which engineering properties are controlled during placement. Also referred to as structural fill.
- **Dense** – with respect to sandy soils, at a relatively high density index or dry density ratio, exhibiting better engineering parameters with respect to strength and stiffness than the same material at a lower density index.
- **Density** – A measure of the mass of material per unit volume.
- **Eccentric Load** – a load incorporating either a varying vertical load and/or a horizontal load such that the peak vertical stress exceeds the average vertical stress.
- **Fill** – Any material that has been placed by anthropogenic processes.
- **Fines** – A component of a soil with particles smaller than 0.075 mm in size.
- **Groundwater** – Water located beneath the earth's surface in pore spaces, fractures and voids in soil or rock.

- **Gravel** – A component of a soil with particles between 2.36 mm and 63 mm in size.
- **Heavily Loaded** – in reference to mobile plant, particularly intended for equipment where ground bearing pressures exceed 50 kPa and/or equipment has a high centre of gravity and could be prone to toppling. In reference to buildings/structures, where footing pressures exceed 100 kPa and/or footing dimensions exceed 1 m wide.
- **Hydraulic Conductivity** – ratio of volume flux to hydraulic gradient – a quantitative measure of soil's ability to transmit water when subjected to a hydraulic gradient. k_{sat} – saturated hydraulic conductivity, intended for dewatering assessment, subsoil drainage design and other engineering assessments where saturated soils are relevant. k_{unsat} – unsaturated hydraulic conductivity, intended for design of stormwater disposal elements such as soakwells and infiltration basins, where the base of disposal elements is above the groundwater level.
- **In situ** – In the place and condition in which it exists naturally. May also refer to fill that is present at any site prior to an investigation taking place.
- **Limestone** – A sedimentary carbonate rock. The use of the term does not infer a specific strength, carbonate content or grain size. Refer to GDR4.1 for further detail.
- **Loose** – with respect to sand soils, at a relatively low density index or dry density ratio, typically indicating poorer engineering parameters with respect to strength and stiffness than the same material at a higher density index.
- **Material** – Matter that meets the definitions of 'soil', 'rock', other engineered matter (i.e., concrete, bricks etc.) or non-engineered matter (organics, contaminated refuse, deleterious material).
- **May** – Indicates that the statement is an option.
- **Must** – Indicates that the statement is mandatory.
- **Natural** – In the context of soil or rock, material which is present as a result of natural geological processes and has not been subject to anthropogenic engineering processes (such as filling, excavation, replacement, etc).
- **Organic** – In the context of soil, material derived from living matter, primarily plants.
- **Overconsolidated** – a soil that has been subjected to a greater vertical stress than its current state.
- **Permeable Soil** – soil that meets the civil design permeability requirements to allow relatively rapid flow of water through the soil matrix.
- **Rock** – Any aggregate of minerals and/or materials that cannot be disaggregated by hand in air or water without prior soaking.
- **Sand** – a component of soil with particle size between 0.075 mm and 2.36 mm.
- **Select Fill** – a controlled fill which has been chosen for particular engineering characteristics (such as strength, CBR, grading, permeability, etc), commonly for use as a higher-grade capping layer or adjacent to structures. Contrast with Bulk Fill.
- **Shall** – Indicates that the statement is mandatory.
- **Should** – Indicates that the statement is a recommendation.
- **Silt** – A component of a soil with particles between 0.075 mm and 0.002 mm in size.
- **Soil** – Particulate materials that occur in the ground and can be disaggregated or remoulded by hand in air or water without prior soaking.
- **Sand** – A component of a soil with particle between 0.075 mm and 2.36 mm in size.
- **Uncontrolled Fill** – Any material that has been deposited by anthropogenic process, which does not meet the definition of 'controlled fill'.

GDR3. GEOTECHNICAL TEST METHODS AND INTERPRETATION

GDR3.1 Test Pit Excavation

Test pit excavations are formed using mechanical excavation equipment (typically an excavator) or hand dug, with the objective of inspecting (or profiling) the soil exposed in the excavation.

Typical limitations on test pit excavations are:

- Limited depth of excavation – typically governed by reach of the excavator arm.
- Cannot be excavated below groundwater in cohesionless soils, due to collapse and water ingress.
- Cannot be excavated through very stiff / very dense soils (i.e., desiccated clays or cemented soils) or most rock.
- Cannot typically obtain rock samples that are suitable for strength testing.

Test pits are usually mechanically excavated with a toothed bucket (intended for excavation in clay or weak rock) or a flat-edged bucket (typically for sands).

When hand-dug test pits are excavated, it is usually for recovery of near-surface soils or inspection of shallow in-ground elements.

We note that where test pits are excavated on a site, they are only ever loosely backfilled during our studies. They must always be located during site preparation works, over-excavated to their full depth and plan extents and re-filled with approved fill in compacted layers.

GDR3.2 Cone Penetration Tests (CPTs)

Cone penetration testing (CPT) is done by Galt or specialist contractors and typically to AS1289.6.5.1. The test involves pushing an instrumented cone into the soil with a hydraulically operated pushing frame. The test measures tip resistance and sleeve friction on the cone, which are then plotted with depth.

We interpret soil types and associated geotechnical soil parameters from CPT data using the following:

Technical Interpretations and International Guides

- Robertson P.K., Campanella R.G., Gillespie D. and Grieg J. (1986). "Use of piezometer cone data". Proceedings of the ASCE Speciality Conference In Situ '86: Use of In Situ Tests in Geotechnical Engineering, Blacksburg, pp 1263-80, American Society of Civil Engineers (ASCE).
- Robertson, P.K., Cabal K.L. (2016) "Guide to Cone Penetration Testing for Geotechnical Engineering 6th Edition 2015". Gregg Drilling & Testing, Inc., California.
- Baldi G., Bellotti R., Ghionna V.H., Jamiolkowski M., Lo Presti D. C. (1989) "Modulus of sands from CPTs and DMTs". Proc. 12th Int. Conf. on SMFE, Rio de Janeiro, Vol 1, p165-170, Balkema, Rotterdam.

Local (Perth and Western Australia) Research, Interpretation and Guides

- Fahey, M., Lehane, B., Stewart, D. (2003) "Soil stiffness for shallow foundation design in the Perth CBD". Australian Geomechanics Vol. 8 No. 3.
- Main Roads Western Australia (MRWA) (2009) "Structures Engineering Design Manual". Document 3912/03, Perth.
- Lehane B. (2017). "CPT-Based Design of Foundations", E.H. Davis Memorial Lecture, Australian Geomechanics, Vol 54. No. 4' and
- Galt's in-house correlations between CPT data and other geotechnical testing.

GDR3.3 Borehole Drilling

Boreholes are drilled for sampling of the soil and rock, with a small disturbance footprint. Typical techniques are:

- Auger drilling (hand auger or machine auger) – for recovery of soil at relatively shallow depths only. Cannot penetrate cemented soils or rock.
- Push probe drilling – for recovery of soil at relatively shallow depths and below groundwater. Cannot penetrate cemented soils or rock.
- Air core drilling – for recovery of soil, cemented soil and rock (typically up to high strength rock). Not suited to drilling of very high strength rock.
- Diamond coring (or rotary coring) – for recovery of cemented soil, rock and some soil types (typically not sand). Suited to all strengths of rock.

If used, standard penetration tests (SPTs) are done in accordance with AS1289.6.3.1. Correlations for consistency and density are based on:

- Standards Australia (2016), “HB160-2006, Soils Testing”.

GDR3.4 Dynamic Cone Penetrometer (DCP)

The DCP is a hand-held tool for assessing penetration resistance of a soil. This comprises a 16 mm rod equipped with a 20 mm cone, hammered into the ground using a falling 9 kg weight on a 510 mm slide hammer on the top of the rod. This is done in accordance with AS1289.6.3.2 and the blow counts to hammer in the rod are measured in 100 mm penetration increments. Where provided, correlations for consistency and density are based on:

- Standards Australia (2016), “HB160-2006, Soils Testing”.

GDR3.5 Perth Sand Penetrometer (PSP)

The PSP is a variation on a DCP and uses a 9 kg weight on a 600 mm slide hammer to hammer in a 16 mm rod with a blunt (square-faced) end. Testing is done in accordance with AS1289.6.3.3, with the following typical variations:

- Testing is often done to a greater depth than the 450 mm covered in the standard.
- Blow counts are sometimes recorded in 150 mm intervals (compared to 300 mm intervals used in the standard) to provide better resolution on the tests.

Where provided, correlations for density are based on:

- Standards Australia (2016), “HB160-2006, Soils Testing”.

GDR3.6 Dynamic Probing Super Heavy (DPSH)

The DPSH test involves driving a solid cone (20 cm²) into the ground using a 63.5 kg hammer falling 760 mm. Testing is done in accordance with EN ISO 22476-2 – Geotechnical engineering – Field testing – Part 2: Dynamic probing – DPSH-B.

Results may be presented as either:

- N10 (No. of blows required for every 100 mm penetration);
- N30 (No. of blows required for every 300 mm penetration); or
- q_d (dynamic tip resistance, analogous to CPT q_c).

GDR3.7 Inverse Auger Hole Infiltration Test (Falling Head, Unsaturated Soil)

Infiltration tests are carried out using the ‘inverse auger hole’ method described by:

- Cocks, G (2007), “Disposal of Stormwater Runoff by Soakage in Perth Western Australia”, Journal and News of the Australian Geomechanics Society, Volume 42 No. 3, pp 101-114

This test is an unsaturated falling head test, in that it is carried out above the groundwater table and is intended to mimic the behaviour of soak wells and similar drainage elements (i.e. soakage basins), which discharge stormwater into an unsaturated medium.

The hole is wetted only for a short period prior to the testing.

The test is usually repeated three times, with the intention that the second and third tests provide similar results (within about 10%-20%). Tests are done over a short duration, typically 2 minutes to 10 minutes. The focus of the testing is generally when the head is low (200 mm or lower), such that the relevant lateral zone is as saturated as the zone directly below the borehole.

The hydraulic conductivity derived from this test is not to be used for applications where saturated hydraulic conductivity is relevant, e.g.:

- Subsoil drainage design; and
- Dewatering estimations.

Based on Galt’s in-house research, this method does not completely saturate the soil in any reasonable test length, and thus may not be suitable for assessment of soils at sites where the critical drainage condition is a fully saturated soil (i.e., in areas with high groundwater tables). Our research on sand sites indicates that the test does correlate well with actual soak well performance, in unsaturated sand zones without impermeable zones.

GDR3.8 Guelph Permeameter Test (Constant Head, Quasi-Saturated Soil)

The Guelph permeameter test, conducted in accordance with the constant head test method outlined in Appendix G of AS1547, is a constant-head test in nominally “saturated” soil (in that the test is conducted until a “steady state” is reached). However, we note that this test can only be done above the groundwater table and as such, is in an unsaturated zone. Therefore, the hydraulic conductivity derived from this test should be used with caution and evaluated against other test methods (such as saturated, constant-head permeability testing from laboratory samples, or in situ saturated hydraulic conductivity testing below the groundwater table).

GDR4. GEOLOGICAL UNITS

GDR4.1 Limestone

The term ‘Limestone’ is used to describe a carbonate rock. Tamala Limestone is the common limestone in Western Australia, and typically comprises cemented quartz and shell fragments cemented together by calcium carbonate.

Limestone can vary significantly across short distances in composition, strength and cementation. Tamala limestones in Western Australia also have known possible geological features including:

- Caprock/calcrete – The formation of a very hard duricrust, usually due to sun exposure. Caprock may be up to 3 m thick, but typically around 1.5 m thick. Caprock is very difficult to excavate and may require the use of hydraulic rock breakers or rock saws to excavate.
- Solution features/tubes – Often initially formed due to the presence of Eucalypt and Jarrah roots during limestone formation, and often increasing in depth and size due to ongoing weathering. May be up to 500 mm in diameter. These are typically filled with very loose, unconsolidated sand.

- Pinnacles – Pinnacles are usually the limestone that is left around surrounding solution features. Often can comprise very hard limestone/caprock that can be substantially higher than surrounding areas. Pinnacles may have also been formed by surrounding erosion (i.e., wind/water).
- Karst/caves – Karst is caused by the dissolution of limestone, typically where there is interaction in low-lying areas with water and limestone. Karst manifests itself as loose near-surface sand with cavities (caves) in the underlying limestone. This can lead to sinkholes and collapse of overlying structures.

Inline images showing typical pinnacle/solution features and Karstic features follow. These are taken from:

- Gordon, R. (2003). “Coastal Limestones”. Australian Geomechanics Vol.38 No. 4, The Engineering Geology of Perth.
- Waltham, A. & Fookes, P. (2003). “Engineering Classification of Karst Ground Conditions: Quarterly Journal of Engineering Geology and Hydrogeology, Vol 36.

Inline Image GDR 1 - Karstic Sinkhole Features from Waltham and Fookes (2003)

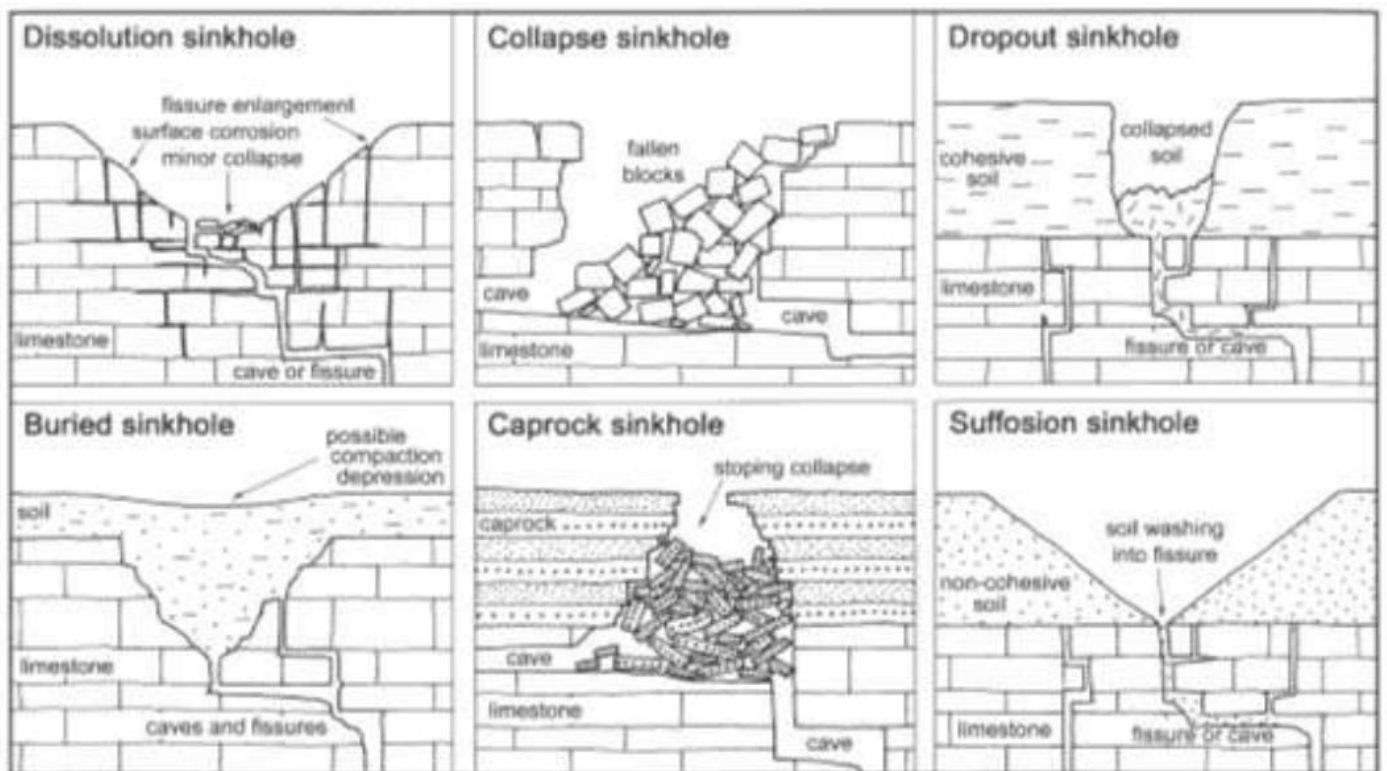

Inline Image GDR 2: Pinnacle/Solution Features from Gordon (2003)

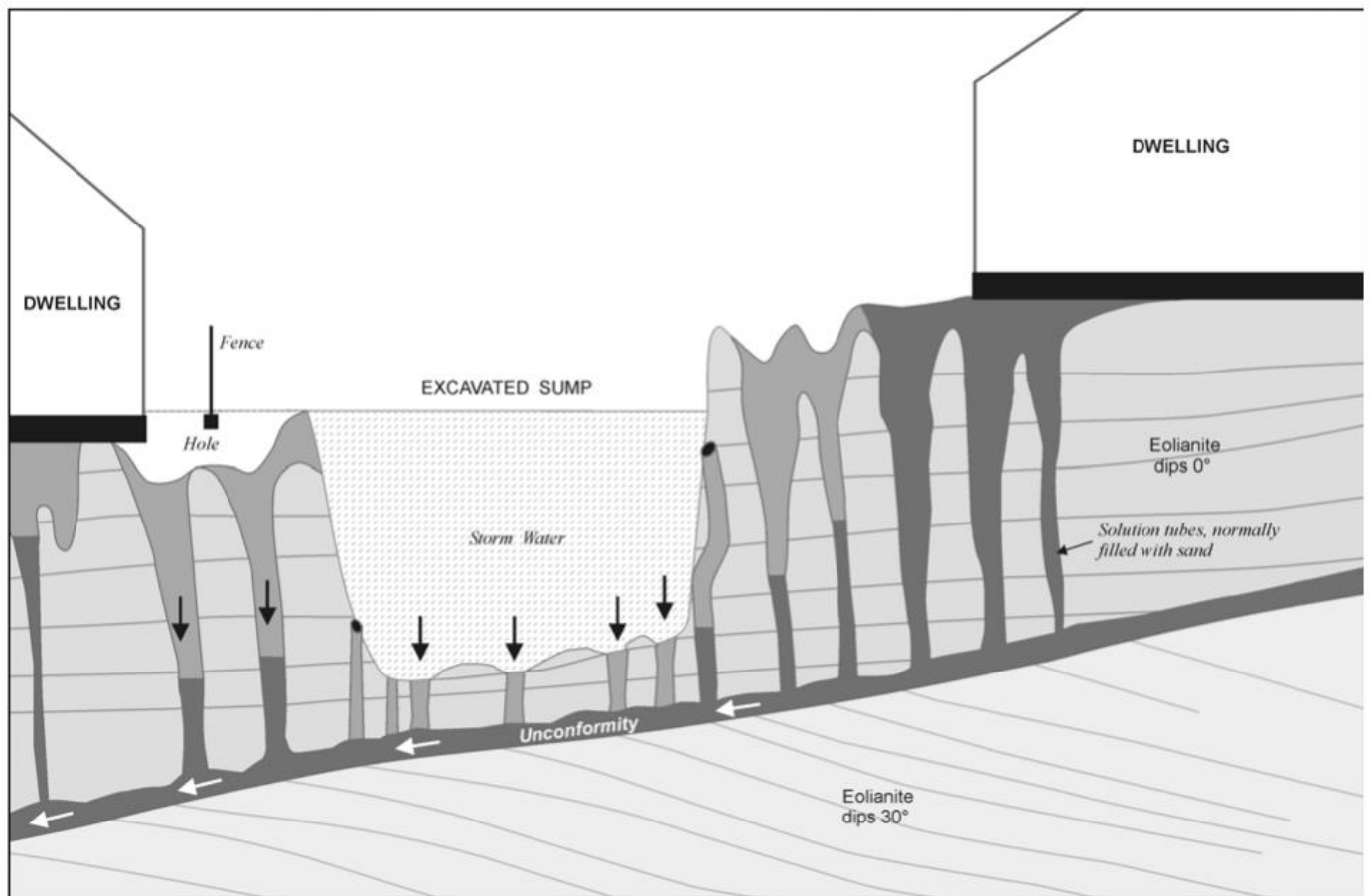

GDR4.2 Pindan Sands and Collapsible Soils

In the Western Australian context, Pindan sands are sandy soils present predominantly across the Pilbara and Kimberley regions. Pindan sands are typically:

- Red brown in colour.
- Between 10% and 40% fines.
- Of aeolian origin, usually resulting in unconsolidated in situ conditions (nuclear density gauge testing often indicates these soils have in situ density ratios of 80%-85% of modified maximum dry density).
- Very strong when dry due to high soil suctions in the fine fraction, which create strong bonds between the sand particles.

As the grains are usually held in place by the dry fine fraction, this can lead to:

- very high settlements (i.e., “collapse”) as the grain-to-grain bonds are weakened as matric suction decreases on soaking; and
- loss of vertical and horizontal strength/stiffness as the grain-to-grain bonds weaken.

The risks associate with Pindan sands are usually quantified in terms of the collapse potential/magnitude of possible collapse events.

Other similar soils are present in Western Australia that may exhibit similar collapse potential and may not strictly be Pindan sands (i.e., have other grain-to-grain bonding mechanisms).

GDR5. SITE CLASSIFICATION

Site classification refers to the assessment of a site in reference to AS2870-2011, “Residential slabs and footings”. The method for assessing the site class is outlined in Section 2 of AS2870-2011, which indicates that this may be done by:

- assessing the characteristic surface movement, due to seasonal moisture changes in the soil profile;
- assessing the performance of existing foundations; or
- assessment of the soil profile (where there are deleterious inclusions, landfill, putrescible waste etc.).

The site classifications based on the expected characteristic surface movement are summarised in Table GDR 1.

Table GDR 1: Summary of Site Classifications (AS2870-2011)

Class	Description	Characteristic Surface Movement (y_s)
A	Most sand and rock site with little or no ground movement from moisture change	Not Defined (typically <5 mm)
S	Slightly reactive clay sites with only slight ground movement from moisture changes	0 – 20 mm
M	Moderately reactive clay sites, which may experience moderate ground movements from moisture change	20 – 40 mm
H1	Highly reactive sites, which may experience high ground movements from moisture change	40 – 60 mm
H2	Highly reactive sites, which may experience very high ground movements from moisture change	60 – 75 mm
E	Extremely reactive sites, which may experience extreme ground movements from moisture change	>75 mm
P	Sites which include soft soils, such as soft clay or silt or loose sands; landslip; mine subsidence; collapsing soils; soils subject to erosion; reactive sites subject to abnormal moisture conditions or sites which cannot be classified otherwise	Not Defined

The calculated characteristic surface movement is predominantly based on:

- the reactivity (i.e., the shrink-swell potential) of the soil (and any proposed fill);
- the design depth of soil suction change, which is the maximum expected depth of soil suction change due to seasonal soil moisture changes; and
- the depth to any bedrock and groundwater table.

The design depth of soil suction change for Western Australia has been refined using the Thornthwaite Moisture Index (TMI). We have carried out assessment using the depths as detailed in:

- Hu Y, Saraceni P, Cocks G, Zhou M (2016). “TMI assessment and climate zones in Western Australia”. Australian Geomechanics Journal, Vol.51 No.3.
- Hu Y, Raj A, Cocks G, Verheyde F (2019). “Re-assessment of TMI based climate zones in metropolitan Perth, WA”. ANZ Geomechanics Conference 2019, Perth Australia.

The design depth of soil suction change for Northern Territory is based on the research presented in:

- Jackson, S (2022), “Thornthwaite moisture index and climate zones in the Northern Territory”, Australian Geomechanics Journal, Vol. 57 No. 3.

We highlight that AS2870-2011 does not make any reference to the fines content of a soil when assessing the site classification.

Where a site classification is provided in our reports, it is always predicated on the requirement that the recommended site preparation procedures are carried out.

We also highlight that the footing performance and shrink-swell movements of a site can be impacted by the planting or removal of trees. This should be considered where appropriate, and we refer to the CSIRO BTF 18-2011 "Foundation Maintenance and Footing Performance: A Homeowner's Guide" for further information.

AS 2870 is limited to single and double storey residential buildings with normal shallow footings with a maximum bearing pressure of 100 kPa and is not applicable where development types other than this are proposed.

GDR6. SITE PREPARATION

GDR6.1 General

The intent of the site preparation guidelines provided in the above report are to ensure that the earthworks can be constructed to meet specific requirements, i.e., minimum compaction, fill requirements, removal of unsuitable material etc. The site preparation guidelines are not exhaustive, and on-site conditions may dictate that other preparation measures may be required to meet geotechnical requirements.

GDR6.2 Site Preparation

Site preparation measures outlined in this section relate to bulk earthworks at the site in preparation for the construction of buildings, pavements and other structures.

The preparation of a site in accordance with outlined measures below or those presented in the report text does not imply that the site is suitable for heavily loaded plant or eccentric loads. This is especially applicable for working platforms for mobile plant including cranes, crawlers or the like. The site surface may still not be trafficable for mobile plant. Individual working platform assessments must be done if heavily loaded mobile plant are proposed.

GDR6.2.1 Common Measures

The common measures outlined below are to prepare standard sites in advance of proof compaction, bulk excavation and filling. These measures are applicable to most sites, however the applicability of these measures is stated in the main report.

Table GDR 2: Common Measures

Measure	Commentary
Demolish and remove structures and pavements	Demolish existing structures and pavements, including removal of all buried services and footings and dispose off-site.
Remove demolition debris and other deleterious material	Remove any demolition debris and other deleterious material from site including old footings, slabs, soak wells, buried services, paving and building rubble.
Strip uncontrolled fill (where present)	Strip any uncontrolled fill from the site (where encountered) and, if suitable, stockpile it for potential re-use as non-structural fill. If contaminated, dispose off-site. Refer to the report text for discussions on the presence of detected uncontrolled fill and its composition. It is important to realise that undetected uncontrolled fill may be present between test locations and the absence of its identification in our report does not preclude its presence. If uncontrolled fill is detected during site works, please contact us for inspection and to provide recommendations.
Remove trees	All tree roots must be removed, this may result in significant excavation in places. Where tree roots and stumps are removed, the disturbed soil must be over-excavated and replaced with controlled, compacted fill. Backfilling of over-excavations is discussed in the following sections .

Measure	Commentary
Strip and stockpile topsoil.	Strip and stockpile topsoil from unpaved areas of the site for potential re-use in non-structural applications. The topsoil strip is only necessary to remove roots and we recommend a topsoil strip as necessary to remove all roots from the soil.
Carry out bulk excavation	Excavate to the required level. Stockpile suitable excavated material for potential re-use as fill (the re-use of spoil as fill, if appropriate, is discussed in the report text) and remove unsuitable or excess material off-site.
Batter edges of excavation	Excavations should be battered to a temporary slope as given in the report text where applicable and not in close proximity to adjacent structures etc. If required, construct temporary/permanent retaining walls where batters cannot be accommodated.

By following these measures, the site should have been prepared to a point where topsoil and vegetation has been removed to expose either natural soil or controlled fill. Over-excavation to the required levels may then be required for some projects. Once complete, the site is now ready for proof compaction and filling.

GDR6.2.2 Sand Sites

The preparation measures outlined below are provided for sand sites meeting the following criteria:

- Site underlain by sand.
- No collapsible soils present.
- No deep loose sand.
- Compaction of a loose upper horizon to maximum 1 m depth.
- No shallow groundwater (<1 m deep).
- No limestone or other rock present at shallow depth.
- “Common Measures” outlined in Section GDR6.2.1 have been completed (as required).

The applicability of these measures is stated in the main report. These measures must be carried out for all areas where structures, footings, pavements and any other settlement-sensitive infrastructure is proposed.

Unless specified otherwise in the report, the **Approved Fill** to be used is outlined in Section GDR8 (**Permeable Sand** where permeable fill is required, else **General Sand**). The specific selection is subject to the requirements of the civil designer.

Table GDR 3: Sand Site Measures

Measure	Commentary
Moisture condition and proof compact.	Moisture condition and compact the exposed sandy ground to achieve the density specified in Section GDR7.1 (“sand”) to a depth of at least 900 mm.
Test proof compaction	Check that the density specified in Section GDR7.1 (“sand”) has been achieved to a depth of at least 900 mm. We note that the applicability of the use of the PSP for compaction control is discussed in the report. Unless specifically approved for use on the subject site, the contractor must not assume that the use of the PSP is appropriate.
Treat areas of loose or unsuitable material	Any areas of loose sand or unsuitable material (including over-excavated areas of former trees and root balls) must be removed and replaced with Approved Fill as outlined in the report or as noted above. The report will explain the suitability of site-derived materials for re-use as approved fill.
Carry out bulk filling	Where fill is required to build up levels, use Approved Fill , placed and compacted in layers of no greater than 300 mm loose thickness. Test compaction to achieve the density specified in Section GDR7.1.

In following this method, shallow/surficial loose sand will be compacted, and the site will be filled (where required) in preparation for supporting footings, ground slabs, pavements and the like.

GDR6.2.3 Deep Loose Sand Sites

The preparation measures outlined below are provided for sand sites meeting the following criteria:

- Site underlain by sand.
- Collapsible soils or deep loose sand present (if applicable, this is discussed in the report).
- Over-excavation, compaction and replacement of loose sand required.
- No shallow groundwater (<1 m deep).
- No limestone or other rock present at shallow depth.
- “Common Measures” outlined in Section GDR6.2.1 have been completed.

The greatest depth of compaction that can be achieved with standard compaction equipment (vibrating roller, etc) is around 1 m (for sands). As such, it is necessary to cut down the site level to a point where this compaction can be done to the lowest level needed to be improved.

The applicability of these measures is stated in the main report. These measures must be carried out for all areas where structures, footings and any other settlement-sensitive infrastructure are proposed. Not typically required for pavement subgrades, however, this is discussed in the report if required.

Unless specified otherwise in the report, the **Approved Fill** to be used is outlined in Section GDR8 (**Permeable Sand** where permeable fill is required, else **General Sand**). The specific selection is subject to the requirements of the civil designer.

Table GDR 4: Deep Loose Sand Site Measures

Measure	Commentary
Over-excavate to the required depth.	Over-excavate sand soil to the depth stated in the report and, if appropriate (discussed in report) retain it for re-use as fill. Over-excavation is likely to be done in stages depending on the site area available for earthworks. Excavations must be battered to a temporary slope as given in the report text where applicable and not in close proximity to adjacent structures etc. If required, construct temporary/permanent retaining walls where batters cannot be accommodated.
Moisture condition and proof compact.	Moisture condition and compact the exposed sandy ground to achieve the density specified in Section GDR7.1 (“sand”) to a depth of at least 900 mm.
Test proof compaction	Check that the density specified in Section GDR7.1 (“sand”) has been achieved to a depth of at least 900 mm. We note that the applicability of the use of the PSP for compaction control is discussed in the report. Unless specifically approved for use on the subject site, the contractor must not assume that the use of the PSP is appropriate.
Treat areas of loose or unsuitable material	Any areas of loose sand or unsuitable material (including over-excavated areas of former trees and root balls) must be removed and replaced with compacted Approved Fill as outlined in the report or as noted above. The report will explain the suitability of site-derived materials for re-use as approved fill.
Carry out bulk filling	Where fill is required to build up levels (including restoration of the site surface level to the original level), use Approved Fill , placed and compacted in layers of no greater than 300 mm loose thickness. Test compaction as specified in Section GDR7.1.

In following this method, deep, loose sand will be compacted to a sufficient depth to reduce settlement impacts and the site will be filled (where required) in preparation for supporting footings, ground slabs, pavements and the like.

GDR6.2.4 Clayey Sites

The preparation measures outlined below are provided for sand sites meeting the following criteria:

- Site underlain by cohesive soils (typically >12% fines, i.e., clayey enough for the fines proportion of the soil to dominate behaviour).
- No collapsible soils present.
- No deep soft soils or organic soils.
- Over consolidated clayey soils present which will not be subject to significant primary or secondary consolidation (settlements expected to be within the limit of typical seasonal movements occasioned by moisture content changes, which would be captured in assignment of an AS2870 site classification).
- No shallow groundwater (<1 m deep)
- No rock present at shallow depth.
- “Common Measures” outlined in Section GDR6.2.1 have been completed.

The applicability of these measures is stated in the main report. These measures must be carried out for all areas where structures, footings, pavement subgrades and any other settlement-sensitive infrastructure is proposed.

Unless specified otherwise in the report, the **Approved Fill** to be used is **Clay** as outlined in Section GDR8.

Table GDR 5: Clay Site Measures

Measure	Commentary
Moisture condition and proof compact.	Moisture condition and compact the exposed clayey ground to achieve the density specified in Section GDR7.1 (“fine grained soils”) to a depth of at least 300 mm.
Test proof compaction	Check that the density specified in Section GDR7.1 (“fine grained soils”) has been achieved to a depth of at least 300 mm. The use of a penetrometer for compaction control of cohesive soils is not an appropriate substitute for in situ NDG testing.
Treat areas of loose or unsuitable material	Any areas of soft clayey soils or unsuitable material (including over-excavated areas of former trees and root balls) must be removed and replaced with compacted Approved Fill . The report will explain the suitability of site-derived materials for re-use as approved fill.
Carry out bulk filling	Where excavations are done into clayey soils (e.g. to treat soft zones, remove root balls and the like), they must not be backfilled filled with sand fill (even where a sand topping layer is proposed). Where fill is required (including backfilling of excavations to remove trees), only use Approved Fill , moisture conditioned, placed and compacted in layers of no greater than 300 mm loose thickness. Test moisture and compaction as specified in Section GDR7.1.
Grade completed clayey surface	Surface water control is essential for clayey sites. This also applies to control of infiltrated water into sand topping layers or the like. The surface of clayey ground must be graded at a minimum of 1% crossfall to drain. This is a general recommendation and an appropriate civil design must be done to account for surface and subsoil drainage.
Install sand topping layer	Where a sand topping layer is proposed, this should be done as outlined in Section GDR6.2.5.

These measures do not take into account the objectives of the civil design for the site, particularly with regard to surface water drainage and groundwater control (including clay grading, subsoil drainage, thickness and composition of a sand topping layer and the like). This must be taken into account by the civil designer. General commentary on drainage control measures is presented in Section GDR14.

GDR6.2.5 Sand Topping Layer

Where a sand topping layer is required:

Unless specified otherwise in the report, the **Approved Fill** to be used is outlined in Section GDR8 (**Permeable Sand** where permeable fill is required, else **General Sand**). The specific selection is subject to the requirements of the civil designer.

Table GDR 6: Sand Topping Layer Measures

Measure	Commentary
Prepare Substrate	Prepare the clayey or other substrate as separately outlined prior to installing the topping layer.
Build up sand topping layer	Build up level to the required level with Approved Fill , placed and compacted in layers of no greater than 300 mm loose thickness to achieve the density specified in Section GDR7.1.

For the purposes of achieving the allowable bearing pressures and site classification discussed in the report, it is not necessary to have the bases of slabs and footings in the sand topping layer, i.e. if required, they may extend through the sand topping layer into clayey soil below.

GDR6.2.6 Limestone Sites

The preparation measures outlined below are provided for sites underlain by limestone (refer to Section GDR4.1), meeting the following criteria:

- Site underlain by sand overlying limestone.
- Compaction of a loose upper horizon to maximum 1 m depth, with localised deeper treatments between pinnacles if required.
- No shallow groundwater (<1 m deep)
- “Common Measures” outlined in Section GDR6.2.1 have been completed.

The site preparation measures outlined below are aimed at improvement of the site in preparation for construction of the structures including on-ground slabs, shallow footings, retaining walls and pavements.

Unless specified otherwise in the report, the **Approved Fill** may comprise one of the following as specified in Section GDR8 (the specific selection is subject to the requirements of the civil designer):

- **Permeable Sand** where permeable fill is required
- **General Sand** where permeable fill is not required
- **Mixed Sand/Limestone Fill** where permeable fill is not required

The re-use of any limestone for fill is subject to the requirements of the civil design and discussions in the report text. The use of **Mixed Sand/Limestone Fill** is discussed in Section GDR6.2.7. The preparation measures outlined in Table GDR 7 assume sand fill.

Table GDR 7: Standard Limestone Site Measures (Bulk Earthworks)

Measure	Commentary
Treat zones of loose sand	Where deep loose sand is present (particularly, but not exclusively, between limestone pinnacles), over-excavate to the depth as noted in the report. Sand should be retained for re-use as fill if recommended in the report. Limestone debris and pinnacles should be separated and only re-used if recommended in the report.
Moisture condition and proof compact.	Moisture condition and compact the exposed sandy ground to achieve the density specified in Section GDR7.1 (“sand”) to a depth of at least 900 mm. Proof compaction of intact limestone is not required.
Test proof compaction	Check that the density specified in Section GDR7.1 (“sand”) has been achieved to a depth of at least 900 mm. We note that the applicability of the use of the PSP for compaction control is discussed in the report. Unless specifically approved for use on the subject site, the contractor must not assume that the use of the PSP is appropriate.

Measure	Commentary
	If refusal to the test method is encountered within the target test depth on limestone and the results to the refusal depth are acceptable, it is not necessary to repeat compaction testing at that location. Compaction control of intact limestone is not required.
Treat areas of loose or unsuitable material	Any areas of loose sand or unsuitable material (including over-excavated areas of former trees and root balls) must be removed and replaced with compacted Approved Fill as outlined in the report or as noted above. The report will explain the suitability of site-derived materials for re-use as approved fill.
Carry out bulk filling	Where fill is required to build up levels, use Approved Fill , placed and compacted in layers of no greater than 300 mm loose thickness. Test compaction to achieve the density specified in Section GDR7.1.

These measures do not take into account the specifics of the civil design, including the requirement (if any) for excavatable and/or free draining layers to achieve construction and drainage objectives. The civil design must take precedence and is not specifically considered in this advice.

Soakwells can perform poorly in limestone and specific advice may apply to the installation of soakwells in limestone areas. If not discussed in our report, please contact us for further advice.

Without further consultation with the structural designer, footings for any one structure must not be founded on a mixture of sand and intact limestone. This is due to potential differential settlements between limestone zones (relatively stiff) and soil zones (relatively soft). Where this is the case, the measures outlined in Table GDR 8 must be followed, only with guidance from the structural designer and Galt.

Table GDR 8: Standard Limestone Site Measures (Footing and Slab Preparation)

Measure	Commentary
Excavate and compact for slabs, subgrades, pad or strip footings	Excavate for pad and strip footings. Where a mix of soil and limestone is present below any one structure, one of the following must be done (to be agreed with structural designer and us): <ul style="list-style-type: none"> ▪ Over-excavate limestone and replace with compacted soil: Typically where the foundation largely comprises soil and a relatively small amount of limestone is present. Where footings and slabs are founded partly on soil and partly on limestone, over-excavate the limestone by at least 300 mm below the base of footing or slab and replace the excavated material with compacted Approved Fill. ▪ Remove soil from over limestone and replace with concrete: Typically where the foundation largely comprises limestone and a relatively small amount of soil is present. Localised zones of sand and mixed sand/limestone rubble must be removed and replaced with lean-mix concrete, e.g. 10 MPa blinding concrete. ▪ Design the structure to accommodate differential foundation movements: For example, include construction joints or use a more heavily reinforced footing (subject to the structural designer's requirements).
Test compaction of footing bases, slabs or subgrades.	Compact the exposed bases to achieve the density specified in Section GDR7.1 ("sand"), to a depth of at least 900 mm, or to the depth where limestone is intersected. If refusal to the test method is encountered within the target test depth on limestone and the results to the refusal depth are acceptable, it is not necessary to repeat compaction testing at that location. Compaction control of intact limestone is not required. Remove, replace and compact as required with approved fill any zone not achieving the density specified in Section GDR7.1 ("sand")

GDR6.2.7 Mixed Sand/Limestone Filling

On sites where deemed appropriate by the Civil Design, **Approved Fill** may comprise limestone rubble fill (**Mixed Sand/Limestone**, as specified in Section GDR8).

The preparation measures outlined below are provided for sites meeting the following criteria:

- No shallow groundwater (<1 m deep)
- “Common Measures” outlined in Section GDR GDR6.2.1 have been completed.
- Substrate preparation for the relevant site type has been done in preparation for further filling (as relevant for sand, limestone or clayey sites discussed in the preceding sections).

The site preparation measures outlined below are required prior to construction of structures including on-ground slabs, shallow footings, retaining walls and pavements.

Table GDR 9: Mixed Sand/Limestone Fill Measures

Measure	Commentary
Develop a method specification for the filling	A performance specification is not appropriate for compaction control in Mixed Sand/Limestone fill, due to oversized limestone particles and the limitations of test methods. Therefore, a method specification is required. Development of a method specification is discussed in Section GDR7.5. A tentative method specification for Mixed Sand/Limestone Fill preparation is also provided.
Carry out bulk filling	Where fill is required to build up levels, use Approved Fill , placed and compacted in accordance with the developed method specification.
Maintain Construction Records	As performance testing cannot be done, quality assurance records are limited. Therefore, the parameters mentioned in Section GDR7.5.1 must be kept in a comprehensive record of the earthworks done to the developed method specification. The use of the PSP is possible <u>only to check for loose sand zones between limestone particles</u> . High PSP blow counts, where limestone particles are intersected, are meaningless in terms of assessing density of the prepared fill. The primary means of validation of the earthworks is conformance with the developed method specification.
Install sand topping layer	Where a sand topping layer is proposed, this should be done as outlined in Section GDR6.2.5.

These measures do not take into account the specifics of the civil design, including the requirement (if any) for excavatable and/or free draining layers to achieve construction and drainage objectives. The civil design must take precedence and is not specifically considered in this advice.

Soakwells can perform poorly in limestone fill and specific advice may apply to the installation of soakwells in limestone fill areas. If not discussed in our report, please contact us for further advice.

GDR6.3 Guidance on Sites with Cohesive Soils

Cohesive soils (most commonly, “clayey” soils) require careful moisture conditioning to facilitate compaction. We recommend that the moisture content of the material is between optimum moisture content (OMC) and 2% wet of OMC at the time of placement and compaction. We note that compaction to the densities specified in Section GDR7.1 can be difficult to achieve for clayey material when not appropriately moisture conditioned.

Vibratory padfoot rollers are preferred for compacting cohesive fill to promote proper kneading and interlocking of subsequent layers.

Clayey soils will drain poorly when inundated following rain events and result in saturated conditions that may inhibit compaction of the soil. In general, it is preferable to avoid trying to re-work clayey sites within several days of any substantial rainfall.

We recommend that the surfaces of clayey sites are sealed by compaction (i.e., final compaction should be with a smooth drum roller) and graded to drain (to avoid low spots where water can pond and cause softening) prior to any

rain events. Stripping back of softened materials to expose competent natural or compacted clayey soil is required before continuing earthworks.

If difficulties are experienced during compaction due to water, further advice should be sought from a geotechnical engineer.

GDR6.4 Preparation and Testing of Shallow Footings

It is preferable to dig all footing excavations carefully with a flat-edged bucket to minimise the disturbance of underlying foundation soil.

Where the footing base is disturbed, or compaction is required, this must be done using appropriate compaction equipment particular to the task (as evaluated by the contractor) – typically a ‘jumping jack’, self-propelled plate compactor or an excavator-mounted plate compactor.

All footing bases must be tested to achieve the density requirements of Section GDR7.1. PSP testing of sand foundations is only applicable where the use of the PSP is specifically approved in the report, otherwise all testing is to be done using the NDG.

Sand Topping Layer - Where a sand topping layer is present over a different soil (i.e., clay, limestone etc.), testing of the density of the sand topping layer is only necessary within the thickness of the sand topping layer. Testing does not need to extend into the underlying compacted substrate, which is separately subjected to compaction control.

Mixed Sand/Limestone Fill – Where mixed sand/limestone fill has been installed to a method specification, no compaction control testing is required, however re-compaction of the base must be done as noted above.

In situ limestone – where in situ limestone (weakly or more cemented limestone, with no sand zones or voids) is present at a footing base and no over-excavation has been done (refer to Section GDR6.2.6 regarding over-excavation of footing bases in limestone), then no compaction control testing is required.

Where loose or soft material is encountered, one of the following actions must be taken:

- Over-excavate the loose / soft layer to expose a suitable layer that does meet the required density (Section GDR7.1) and either:
 - Place and compact Approved Fill (relevant to the appropriate preparation measures outlined in Section GDR6.2) to achieve the required density (Section GDR7.1); or
 - Pouring blinding concrete ($f_c > 15$ MPa at 28 days) from the competent layer up to the underside of the footing.

All foundations must be assessed by a competent person prior to blinding.

Measures must be taken to minimise moisture changes in clayey foundation soils at the base of footing excavations. Concrete footings are to be poured soon after excavation to minimise the potential for excessive moisture change. The use of a concrete blinding layer following foundation preparation should be considered.

GDR7. COMPACTION AND MOISTURE CONDITIONING

GDR7.1 Requirements

Any soil within the significant founding zone of structures (buildings, slabs, pavements, etc.) must be suitably moisture conditioned and compacted. These soils must be compacted to the requirements as outlined below.

Table GDR 10: Compaction and Moisture Requirements

Soil Description	Soil Particle Limits	Moisture Requirement	Density Requirement (DDR)	Possible QA/QC Test Methods
Sand	<5% fines <5% gravel <i>Maximum particle size 9.5 mm</i>	MOMC $\pm 2\%$	95% MMDD	PSP NDG
Gravel	<5% fines >50% gravel <i>Maximum particle size 19.0 mm</i>	MOMC $\pm 2\%$	95% MMDD	NDG
Clayey/Silty Gravel	5-35% fines >50% gravel <i>Maximum particle size 19.0 mm</i>	MOMC $\pm 2\%$	95% MMDD	NDG
Sand with fines or gravel	5-35% fines; and/or 5-50% gravel <i>Maximum particle size 19.0 mm</i>	MOMC $\pm 2\%$	95% MMDD	NDG Method Specification
Fine grained soils (Clayey or Silty)	>35% fines <i>Maximum particle size 19.0 mm</i>	MOMC $\pm 2\%$; or SOMC $\pm 2\%^2$	92% MMDD; or 95% SMDD	NDG Method Specification
Oversize/rubblly soil	Any soils with particles >19.0 mm	MOMC $\pm 2\%$	95% MMDD (Or equivalent to)	Method Specification Detailed Assessment Based on Specific Material

- NOTES:**
1. DDR – Dry Density Ratio
MMDD – Modified maximum dry density (AS1289.5.2.1)
MOMC – Modified optimum moisture content (AS1289.5.2.1)
SMDD – Standard maximum dry density (AS1289.5.1.1)
SOMC – Standard optimum moisture content (AS1289.5.1.1)
PSP – Perth Sand Penetrometer
NDG – Nuclear Density Gauge
 2. Preferably OMC to OMC +2%, for ease of compaction and producing a homogenous fill
 3. Test frequencies are specified in Section GDR7.6.

The soil groups and definitions outlined above are generally based on AS1726-2017. Test methods are discussed in subsequent sections.

GDR7.2 Construction Recommendations

Over-excavation and replacement of loose material must be done where the minimum DDR cannot be achieved.

Fill must be placed in horizontal layers of not greater than 300 mm loose thickness. Each layer must be compacted by suitable compaction equipment, and carefully controlled to ensure even compaction over the full area and depth of each layer.

Care will need to be taken if compacting in the vicinity of existing structures, such as the adjacent properties. This is particularly important if vibratory compaction is being carried out.

- Tynan (1973), "Ground Vibration and Damage Effects on Buildings", Australia Road Research Board, Special Report No. 11.

Tynan (1973) provides guidance on the selection of compaction equipment for use adjacent to structures. The distance of influence (i.e., the definition of “vicinity”) will vary depending on the size of compaction plant proposed for use. Where there is concern regarding the impact on nearby structures, a dilapidation study should be done.

GDR7.3 Nuclear Density Gauge

Where applicable, a nuclear density gauge (NDG) must be used in accordance with AS1289.5.8.1. NDG tests must be done to a depth of 300 mm or as otherwise indicated in the text of the attached report.

GDR7.4 Perth Sand Penetrometer

Where clean sand is used (<5% fines and <5% gravel), a Perth sand penetrometer (PSP) may be used for compaction control in accordance with AS1289.6.3.3. Refer to the report for recommended blow counts correlating to the specified density.

Where the fines or gravel contents of a sand soil exceed the maximum contents noted above, a PSP must not be used exclusively for compaction control. As a minimum, ongoing confirmation testing with an NDG is required. If not specified in our report, please contact us for further advice regarding test frequencies.

If difficulties are experienced recording the required blow counts, a site-specific PSP correlation should be carried out to determine the PSP blow count correlating to a DDR of 95% MMDD. In addition, a particle size distribution (PSD) test should be carried out to verify that the use of a PSP is suitable for the sands being tested. A site-specific PSP correlation must:

- be done on site;
- use the nuclear density gauge (NDG) to determine density at a minimum of 5 points with varying density to a depth of 300 mm below surface;
- include at least 1 point where the dry density ratio is in excess of 95% MMDD;
- use a calibrated PSP to determine the PSP blow count from 150 mm to 450 mm at each NDG test point; and
- be plotted on a chart of PSP blow count vs DDR.

Only where specifically stated as applicable in the report and where the use of the PSP is relevant as noted above, the following values may be taken as deemed to conform to a dry density ratio of 95% MMDD for the relevant sand type.

Table GDR 11: Deemed-to-comply Values for PSP Results in Perth Sands

Depth Interval (mm)	Bassendean	Tamala	Calcareous
0-150	SET	SET	SET
150-450	7	8	12
450-750	9	10	14
750-1050	11	12	16

- NOTES:**
1. Blows per 300 mm interval
 2. Bassendean Sand is typically a white - grey, low-fines quartz sand found on the eastern part of the Perth coastal plain
 3. Tamala / Spearwood sand is typically yellow or orange, low-fines quartz sand found on the western part of the Perth coastal plain
 4. Calcareous sands are typically white or yellow, calcareous sand found in low-lying areas on the western fringe of the Perth coastal plain
 5. Values derived from Galt experience on PSP correlations done on sites across Perth for the 150-450 mm interval.

GDR7.5 Method Specifications

GDR7.5.1 General

Where proposed, a method specification should be developed by a geotechnical engineer or similarly qualified person and ratified by us (including a site visit by us). The method specification should be confirmed by the construction of a trial pad or trial area and the compaction methodology should be checked against either:

- density, as assessed using a nuclear density gauge; or
- settlement, as assessed using a dGPS.

Specific advice should be requested for the development of a method specification, taking into consideration the material being compacted.

Method specification compliance should be maintained for all areas on a minimum 20 m grid, with the compliance to include:

- Roller used (weight, style, vibration);
- Water application rate (per lift);
- Layer thickness placed; and
- Number of passes with roller.

GDR7.5.2 Indicative Method Specification – Sand/Limestone Rubble Mix

Where mixed sand/limestone is used as structural fill, a performance specification is not appropriate due to the inaccuracies of standard test methods (NDG/PSP etc.) in this type of material. A method specification can be used instead. The following indicative method specification is provided for evaluation and trial but must be trialled and ratified by us prior to widespread employment on site. The following would be typically adopted:

- Maximum particle size: 250 mm
- Maximum loose layer thickness: 350 mm
- Minimum watering rate: 10 L/m²/100 mm thickness of loose material (e.g. 35 L/m² for a 350 mm thick layer)
- Minimum 8 passes with a vibrating padfoot roller, minimum static weight 10 tonnes.
- The compacted fill must comprise closely packed particles without any significant voids between the larger particles.

GDR7.6 Testing Frequency

After compaction, verify that the required density has been achieved by testing at the base of excavation and through the full depth of any fill, and to a minimum depth of:

- 900 mm where a PSP is used; or
- 300 mm where a NDG is used.

The frequency of testing (when a method specification is not used) should be as follows:

Table GDR 12: Compaction Testing Frequency Requirements

Area	Minimum Testing Frequency	Minimum Tests Per Lot
Proof Compacted Area	1 test per 1,000 m ² (30 m grid)	2
Structural Fill Outside of Building and Pavement Footprints	1 test per 500 m ³ 2 tests per layer <i>Whichever is greater</i>	2
Structural Fill Within Building and Pavement Footprints	1 test per 500 m ³ 4 tests per layer <i>Whichever is greater</i>	4
Spread/Pad Footings	1 test per 9 m ² per footing	1
Strip Footings/Retaining Wall Foundations	Minimum 2 tests At 5 m centres <i>Whichever is greater</i>	2
On-ground slabs, pavements and rafts	Minimum 2 tests At 10 m centres 1 test per 100 m ² <i>Whichever is greater</i>	2

- NOTES:**
1. A 'lot' is defined in the context of this section as a section of earthworks that is undertaken in one operation where the equipment, personnel, materials and methodology are consistent throughout the entire process. This would typically be limited to operations done in one day, but this is not mandatory.
 2. There will frequently be multiple 'lots' in an earthworks process, therefore the number of tests must be adjusted according to the minimum number per lot in this table (where this is more than the frequency specified in 'testing requirements').

GDR7.7 Bulking and Compaction Factors

All soils will "bulk" when excavated to stockpile, and "compact" when placed from stockpile to earthworks layers. Published bulk and compaction factors are presented below for conventional materials, taken from:

- Forssblad, L (1981), "Vibratory Soil and Rock Fill Compaction", Dynapac Maskin AB

Inline Image GDR 3: Volumes of Different Types of Fill Materials in Natural, Loose and Compacted State

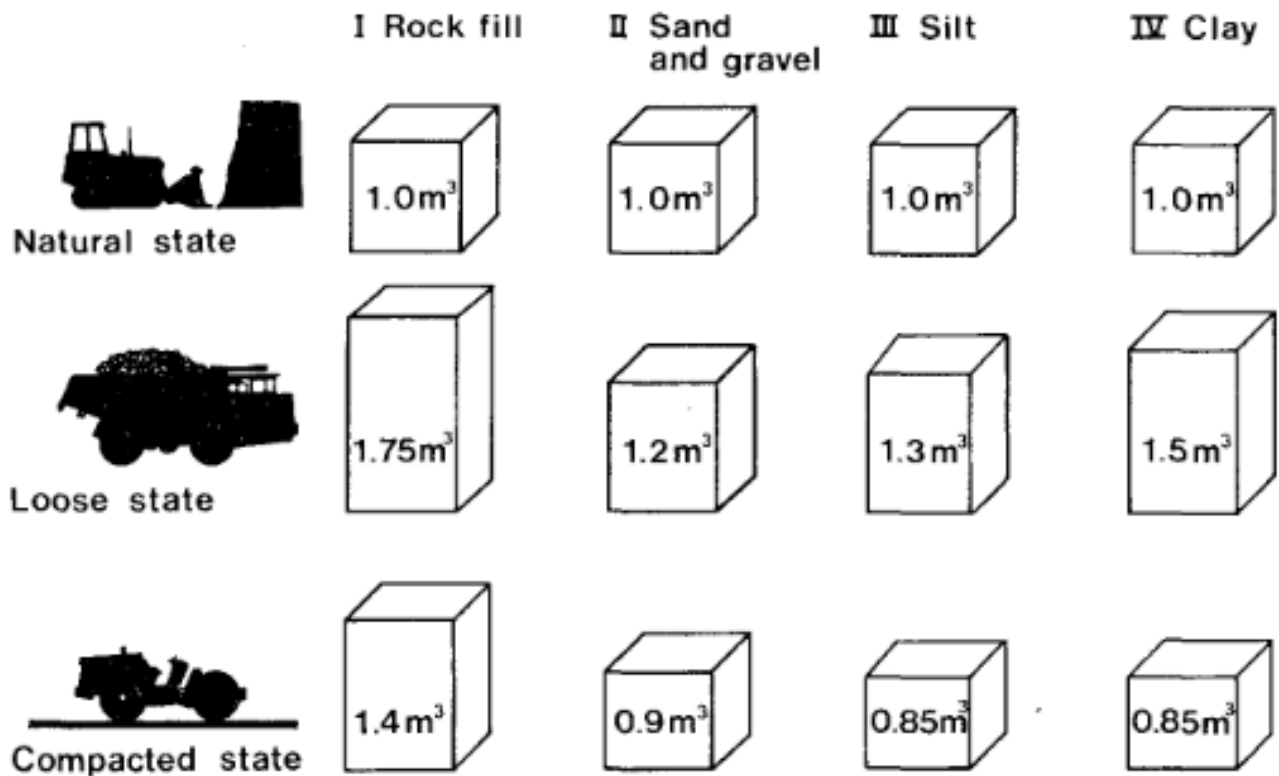

These values are indicative only and will vary according to site specific conditions. The values provided here must not be used for commercial volume estimates or settling disputes regarding volumes.

GDR8. APPROVED FILL AND CONFORMANCE TESTING

Imported fill must comply with the material requirements as stated in AS 3798-2007, “Guidelines on Earthworks for Commercial and Residential Developments”.

Where doubt exists, a geotechnical engineer must be engaged to inspect and approve the use of potential fill materials.

The following table presents recommended material parameters for standard fill types. This does not take account of availability of materials either on site or in the local area. Refer to the report text for specific advice on fill at the subject site.

Table GDR 13: Standard Fill Recommendations

Soil Description	Application	Soil Particle Limits (%) ³				k_{min} ¹ (m/d)	OC ² (%)	Atterberg Limits		CBR ⁶ (%)	Test Method ⁴
		Fines	Sand	Gravel	Max.			LL (%)	PI (%)		
Permeable Sand	Permeable bulk fill Retaining wall backfill Permeable select fill	≤5	≥90	≤5	9.5	5	≤2	NP	NP	≥12	PSP NDG
General Sand	Bulk fill Select fill (permeability not required)	≤5	≥90	≤5	9.5	N/A	≤2	NP	NP	≥12	PSP NDG
Silty Sand	Bulk fill Select fill	≤35	≥55	≤10	9.5	N/A	≤2	<35	<11	≥12	NDG
Clayey Sand	Bulk fill Select fill	≤35	≥55	≤10	9.5	N/A	≤2	<40	N/A	≥12	NDG
Mixed Sand/Limestone	Bulk fill (permeability not required)	≤5	≥20	≤80	250	N/A	≤2	NP	NP	N/A	NDG Method
Blue Metal Gravel ⁸	Retaining wall backfill Drainage trench backfill	≤3	≤5	≥90	37.5	5	≤1	NP	NP	N/A	NDG
Clay ⁷	Reinstatement of localised excavations in clay Bulk fill	≥12	Varies	≤30	19	N/A	≤2	Varies			NDG

- NOTES:**
- k_{min} – minimum saturated hydraulic conductivity (AS1289.6.7.1, remoulded to minimum DDR 100% MMDD).
 - OC – organic content (Walkley-Black method recommended, AS1289.4.1.1 – not loss on ignition methods)
 - % by mass.
 - Test method indicates possible compaction control methods for this material.
PSP – Perth sand penetrometer (AS1289.6.3.3). Where a PSP is used, a site-specific correlation must be done unless otherwise noted in the report.
NDG – Nuclear density gauge (AS1289.5.8.1)
Method – method specification
 - Atterberg Limits: LL – liquid limit PI – plasticity index NP – non-plastic
 - CBR: California bearing ratio (for sand - remoulded to DDR 95% MMDD @ OMC, 4.5 kg surcharge). CBR values may be changed depending on the design pavement requirements.
 - “Clay” fill type is included for broad reference only and to illustrate preferred applications, particle size limits and recommended test method. Specific discussion on the use of clayey fills is included in the report text if applicable. Atterberg limit and CBR testing of clayey fills may be required and advice must be sought from us if not stated in the report.
 - “Blue metal” gravel refers to single sized, crushed, washed igneous rock gravel used for drainage purposes.
 - In the absence of specific test frequencies by the civil designer, the testing shown in Table GDR 14 must be done (highlights in Table GDR 13 show where the test is required).

Table GDR 14: Conformance Testing Frequency Requirements

Parameter	Frequency (m ³)	Minimum Tests per Source	AS1289 Reference
Particle size distribution	5,000	1	3.6.1
Hydraulic conductivity (permeability)	10,000	2	6.7.1
Organic content	5,000	1	4.1.1
Atterberg limits	5,000	1	3.1.1, 3.2.1, 3.3.1
CBR	10,000	2	6.1.1

- NOTES:**
1. Frequency is for the nominal number of cubic metres of compacted fill.
 2. Unless stated otherwise in the report text, the conformance testing must also be carried out on site-derived materials to confirm suitability.

GDR9. SHALLOW FOUNDATIONS

GDR9.1 Design

Footings and slabs may be designed in accordance with the assigned site classification in accordance with AS2870-2011. We note that AS2870-2011 is limited to single and double storey residential and commercial developments and may not be strictly applicable.

Where the report provides tables for shallow footing design, custom footings may be designed by the structural engineer using the data provided therein.

GDR9.2 Interpretation of Provided Values

BEARING PRESSURES

All settlement and bearing pressures estimates are provided on the assumption that the site preparation requirements outlined in the report are completed below all structures plus a minimum distance of 1 m beyond the outside edge of any footing or slab. It is essential that the soil below all foundations is appropriately prepared as outlined and meets the relevant compaction requirements.

Allowable bearing pressures for footings of intermediate plan dimensions (to any tabulated) can be interpolated. Footings that have a plan dimension either smaller or larger than those presented in the report will need to be considered individually along with other embedment depths.

Allowable bearing pressures, where provided, are considered to be the upper limit for shallow footings to limit total and differential settlements. Footings carrying eccentric loading, such as below retaining walls, must be assessed separately.

SETTLEMENTS

The reporting of settlements to any precision level is not intended to imply a high accuracy of settlement prediction. Settlements as reported should be considered 'order of magnitude'.

Estimated settlements represent vertical downwards movement due to loading and do not take into account potential additional movement associated with the characteristic surface movement of the soil (which must be taken in addition to these settlements from loading, refer Section GDR5). The site classification is discussed in the report.

The actual settlement of any proposed structure will depend upon a number of factors including the applied pressures, footing size and base preparation. The estimated settlement(s) provided in this report are for the working bearing pressures as indicated. Differential settlements are likely between footings of similar sizes, loads and elevations (as stated in the report text). A proportion of the settlement is expected to occur during construction (i.e., during initial loading).

The provided settlement estimates (unless otherwise stated) do not include interaction effects from footings founded near other footings (i.e., groups of footings). Interaction effects will need to be considered if the spacing between adjacent footings is smaller than the dimension of the footings (i.e., the centre-to-centre spacing between footings is less than twice the width of the footing). This could act to double provided settlements, dependent on the footing configuration. Where an assessment of footing groups is required, a more detailed numerical or finite-element modelling analysis would need to be undertaken.

CREEP AND CONSOLIDATION

Creep settlement is an irreversible component of long-term soil settlement caused by sustained vertical stress. Consolidation is a time-dependent irreversible compression in a soil layer caused by a reduction in pore pressure between soil particles. Both creep and consolidation can occur in natural materials as a result of earthworks or the placement of loads on to soil layers. The settlements as presented for short-term loading do not include consideration for creep and consolidation settlements unless specifically stated.

GDR9.3 Raft Foundations

Where moduli of subgrade reactions are provided for the design of raft foundations, we highlight that these are an estimate of the elastic reaction of the soil. The values are provided based on an expected load and loaded area size. Soils are typically non-linear in their response and will have different stiffnesses at different levels of strain and load repetitions. This is due to the physical interaction of soil particles under different levels of stress.

The possibility of a non-linear response must be considered by the designer of any raft foundation.

GDR10. PILED FOUNDATIONS

Piles must be designed and tested in accordance with AS2159-2009, "Piling – Design and Installation". We use the following interpretation/design methods to provide pile design parameters:

- Franki Africa Pty Ltd (2008) "A Guide to Practical Geotechnical Engineering in South Africa". 4th ed.
- AFNOR (2012) "NF P 94-262 – Justification des ouvrages géo-techniques, Normes d'application nationale de l'Eurocode 7", Afnor, Paris, July 2012.
- Lehane, B. (2017) "CPT-Based Design of Foundations". E.H Davis Memorial Lecture, Australian Geomechanics Vol 54. No. 4.
- Lehane, B. et al. (2020) "A New 'Unified' CPT-Based Axial Pile Capacity Design for Drivel Piles in Sand". Proceedings of the Fourth International Symposium on Frontiers of Offshore Geotechnics.
- Doan., Lehane, B. (2021) "CPT-Based Design Method for Axial Capacities of Drilled Shafts and Cast-in-place Piles." American Society of Civil Engineers (ASCE), Journal of Geotechnical and Geoenvironmental Engineering.

The pile designer must:

- consider the possible variation in subsurface conditions at each pile location;
- consider any pile group effects based on the final piling configuration;

- assume that the unit shaft resistance in tension is less than 80% of the unit shaft resistance in compression to account for Poisson's effect in sand.

The piling contractor must:

- make their own assessment on the suitability of their equipment to install any piles at the subject site; and
- carry out or appoint a suitably experienced contractor to test the piles in accordance with AS2159.

Where dynamic or static testing of the piles does not occur, we consider that a design geotechnical reduction factor (ϕ_g) of 0.4 is applicable for the pile design. If testing of the piles is proposed by the piling contractor, a higher ϕ_g could be adopted.

Unless otherwise stated, providing pile design parameters does not specifically indicate the driveability of any piles into soil units.

A separate driveability study may be required and must be considered by the pile designer and installer. The given pile design parameters must not be used for driveability assessments as these parameters are likely to be un-conservative.

GDR11. EARTH RETAINING STRUCTURES

GDR11.1 General

Retaining structures may be designed in accordance with AS4678 (2002) "Earth Retaining Structures". Unless otherwise specifically stated, we recommend that all retaining walls are backfilled with free-draining soil (Permeable Sand or Blue Metal Gravel as defined in Section GDR8).

Where the cohesive soil is used as retaining wall backfill, a suitable, permanent drainage system must be placed behind the wall such that a build-up of pore pressure is prevented. A separator geotextile (Bidim A24, or similar, or heavier) must be used between the interface of any granular backfill and the cohesive soil.

Where drainage is not provided, the retaining wall must be designed to accommodate water pressure behind the wall (10 kPa per metre height).

GDR11.2 Earth Pressure Coefficients and Strength Parameters

Where earth pressure coefficients are provided for retaining walls, the wall designer must make an independent assessment of the parameters appropriate to the construction method to be used, including alternative values of wall friction. Unless otherwise stated, we have assumed a horizontal ground surface behind and in front of the retaining wall for provided parameters.

GDR11.2.1 Cohesionless Soils

Where cross-referenced for suitability in the report, the following parameters may be adopted for design of earth retaining structures in cohesionless soils (sand and gravel).

Table GDR 15: Retaining Wall Geotechnical Parameters (Cohesionless Soils)

Density	γ (kN/m ³)	ϕ' (°)	k_0	Wall Friction=0		Wall Friction=0.5 ϕ		Wall Friction=0.67 ϕ	
				k_a	k_p	k_a	k_p	k_a	k_p
Very Loose	17	30	0.44	0.33	3.00	0.29	4.81	0.28	5.74
Loose	17	32	0.42	0.31	3.25	0.27	5.55	0.26	6.83
Medium Dense	18	34	0.39	0.28	3.54	0.25	6.47	0.23	8.26
Dense	19	36	0.36	0.26	3.85	0.22	7.63	0.21	10.18
Very Dense (1)	19	38	0.34	0.24	4.20	0.21	9.11	0.20	12.85
Very Dense (2)	19	40	0.31	0.22	4.60	0.19	11.06	0.18	16.73

- NOTES:**
1. Earth pressure coefficients are provided in this table for conditions of zero friction between the wall and the soil and with wall friction of 0.5 ϕ' or 0.67 ϕ' .
 2. A horizontal ground surface behind and in front of the wall has been assumed.
 3. The retaining wall designer should make an independent assessment of the parameters appropriate to the construction method to be used, including alternative values of wall friction.
 4. γ – bulk unit weight
 ϕ' – effective friction angle
 k_a – coefficient of active earth pressure (Coulomb – AS4678-2002, Appendix E)
 k_p – coefficient of passive earth pressure (Coulomb – AS4678-2002, Appendix E)
 k_0 – coefficient of at-rest earth pressure (Jaky)
 5. Maximum fines content 12% for applicability of this table for design purposes.
 6. Unit weights based on Table D1 of AS4678-2002, for moist bulk weight.
 7. Friction angle based on Equation D1 and Table D2 of AS4678-2002, based on rounded, moderately graded siliceous sand.

GDR11.2.2 Cohesive Soils

Where cohesive soils (i.e. clayey or silty soils) are proposed for backfill, geotechnical design parameters may be provided in the form of effective strength and undrained strength parameters. We note that:

- Undrained strength parameters should be used for analysis of short-term stability, or stability under sudden loading of cohesive soils.
- The effective strength parameters should be used for analysis of free-draining soils and the long-term stability of cohesive soils.

Table GDR 16: Retaining Wall Geotechnical Design Parameters (Cohesive Soils – Undrained)

Consistency	γ_b (kN/m ³)	c_u (kPa)
Soft	17	12
Firm	18	25
Stiff	19	50
Very Stiff	20	100
Hard	20	200

- NOTES:**
1. γ_b – bulk unit weight
 c_u – undrained cohesion
 $\phi_u = 0^\circ$ (undrained friction angle)
 2. Unit weights based on Table D1 of AS4678-2002
 3. Undrained cohesion based on lower end of shear strengths as define in AS1726-2017, Table 11

Table GDR 17: Retaining Wall Geotechnical Design Parameters (Cohesive Soils – Drained)

Fines Content	PI (%)	γ_b (kN/m ³)	ϕ' (°)	c' (kPa) ⁵
12-35%	All	19	32	0
>35%	10	20	30	0 – 5
>35%	20	20	26	0 – 5
>35%	30	20	23	0 – 5
>35%	40	20	21	0 – 5

- NOTES:**
- γ_b – bulk unit weight
 c' – drained cohesion
 ϕ' – effective friction angle
PI – plasticity index
 - Unit weights based on Table D1 of AS4678-2002, assuming generally stiff to hard overconsolidated soils.
 - For fines contents <35% (silty sand and clayey sand), strength parameters based on:
 - Lehane, B. et al (2007) "A Laboratory Investigation of the Upper Horizons of the Perth/Guildford Formation in Perth CBD", Australian Geomechanics Vol 42. No. 3.
 - For fines content >35% (sandy clay), strength parameters based on:
 - CIVL5503 course notes (2004), "Underground Construction", University of Western Australia
 - $c' = 0$ recommended for long-term design. Table D4 of AS4678 suggests c' up to 5 kPa for 'poor' fine grained soils and 10 kPa for 'average' fine-grained soils. The use of c' for design is subject to the designer's judgement but recommended by us only for temporary works.

Per AS4678-2002 Appendix E, horizontal earth pressures for frictional-cohesive soils may be calculated in accordance with the Rankine-Bell design model (illustrated in Figure E2 of AS4678). The earth pressures are as follows (Z = depth, all other terms have the meanings given in the above tables):

- Active: $p_a = \gamma Z \tan^2 \left(45 - \frac{\phi}{2} \right) - 2c \tan \left(45 - \frac{\phi}{2} \right)$
- Passive: $p_p = \gamma Z \tan^2 \left(45 + \frac{\phi}{2} \right) + 2c \tan \left(45 + \frac{\phi}{2} \right)$

GDR11.3 Design and Construction Considerations

Compaction plant can augment the lateral earth pressure acting on retaining walls. Hand operated compaction equipment is recommended within 2 m of any retaining walls to minimise compaction pressures.

Retaining walls can move and rotate under imposed soil loading resulting in settlement behind the wall. This must be considered in the design and during construction of the retaining walls in order that adjacent infrastructure is not adversely affected.

It is important to note that some ground movement will occur behind any soil retaining system, including gravity retaining walls.

GDR12. EXCAVATIONS, BATTERS AND SLOPES

GDR12.1 Excavatability

Our assessment of the excavatability of rock is based on a combination of:

- Our experience on earthworks and construction projects across Australia; and
- Figure 10 of the revised graphical method of assessing excavatability of rock by:

- Pettifer, G.S. & Fookes, P.G., “A revision of the graphical method for assessing the excavatability of rock”, Quarterly Journal of Engineering Geology, 27, pp145-164, 1994.

GDR12.2 Safety

All excavations must be carried out in accordance with:

- Commission for Occupational Safety and Health (2022). “Excavation: Code of Practice”, Department of Mines, Industry Regulation and Safety, 89pp, Perth.

Excavations in cohesionless soils are particularly prone to instability unless support is provided. Care must be exercised in such excavations and appropriate safety measures adopted where necessary, particularly in the vicinity of existing buildings, structures and infrastructure.

The toe of any batter must be at least 500 mm above groundwater (including perched groundwater).

Unless a specific slope stability assessment or retention design has been done, the toe of any excavation should not encroach within a line of 1V:3H to any nearby footings, pavements or other settlement-sensitive structures.

Surcharges (such as structures, plant and soil stockpiles) must not be placed at or close to the crest of unsupported excavations, without a specific slope stability assessment.

A geotechnical engineer must be consulted where there is any doubt regarding the stability or safety of unsupported excavations.

GDR12.3 Batters

Temporary batter slopes provided in the report are subject to the following conditions, unless otherwise stated:

- The maximum slope height is 2 m without specific advice and slope stability analysis.
- The groundwater level for the duration of the excavation must be at least 500 mm below the toe of the slope.
- No surcharges are present in the vicinity of the slope (i.e. must be outside a line of 1V:3H from the toe of the slope).

Unless noted specifically in the report, the following batters may be adopted (maximum height: 2 m):

Table GDR 18: Default Batter Angles

Situation	Material	Batter
Temporary	Cohesionless Soils (Sand/Gravel)	1V:2H
Temporary	Cohesive Soils – Soft	1V:2H
Temporary	Cohesive Soils – Firm, Stiff, Very Stiff or Hard	1V:1H
Temporary	Limestone – Variably Cemented	1V:1H
Temporary	Limestone – Well Cemented	1V:0.5H
Permanent	All Soils	1V:3H
Permanent	Limestone – Variably Cemented	1V:2H
Permanent	Limestone – Well Cemented	1V:1H

Where specified batters cannot be accommodated in the vicinity of existing footings, roads and services, temporary or permanent lateral support will be required.

Specific advice is required for batters higher than 2 m.

Erosion control must be considered for permanent slopes.

Rock slopes must be inspected, and all loose cobbles / boulders removed. Permanent rock slopes may require dentition works or possibly rock catch drains.

GDR12.4 Grouting

Permeation or jet grouting involves injecting a microfine cement into soil to form a grouted soil block (soilcrete) to support excavation and structures. Grouting is typically only effective where the soil has the capacity to “take” the grout and form a uniformly cemented soil mass. Permeation grouting is generally limited to relatively permeable, coarse-grained cohesionless soils (sands and gravels with <5% fines).

If grouting is proposed, we recommend the following:

- Grouting must be carried out by a suitably experienced contractor.
- Only microfine cement grout should be used (not GP or coarse cement blends) to ensure adequate penetration into the soil matrix.
- Grouting should be done on a grid of not greater than 300 m.
- Application rates must be discussed with the contractor.
- The grouted soil mass must have intimate contact with any structures it is intended to support.
- The contractor must satisfy themselves that the proposed grouting can be installed with their equipment and into the subsurface conditions encountered at the site, considering possible obstructions, groundwater, cemented layers, loose sands etc.
- Testing of the grouted soil mass must be done to ensure that the grout has adequately permeated through the soil matrix. This can be done by drilling into the soil mass to ensure the cementation is continuous.

Grouting is most effective on permeable, relatively loose natural sand. Where historical filling or other ground disturbances have occurred, the grouting process can be less effective due to the tendency of grout (or other liquids) to follow more permeable paths / zones through the disturbed soil.

GDR13. STORMWATER DISPOSAL AND DRAINAGE DESIGN

GDR13.1 Groundwater Separation – Controlled Groundwater

These recommendations ONLY apply to where regional controls on groundwater (primarily: subsoil drainage, but also surficial ‘main drains’) exist, i.e. only to areas where groundwater is actively controlled.

The following reference:

- IPWEA (2016), “Specification: Separation Distances for Groundwater Controlled Urban Development”, Institute of Public Works Engineering Australasia

recommends the following separation distances from drainage infrastructure to groundwater:

- Underground infiltration systems: 0 mm from the 50% AEP (annual exceedance probability) phreatic surface.
- Surface infiltration systems (vegetated): 300 mm from the 50% AEP phreatic surface.

The above IPWEA reference also states that performance measures for underground infiltration systems are to have a: *demonstration of acceptable volumetric capacity when groundwater is elevated above base of system and that the groundwater recedes below the invert of the system during mosquito breeding seasons (grated or partially open systems).*

GDR13.2 Groundwater Separation – Uncontrolled Groundwater

These recommendations apply where regional controls on groundwater levels are not present. For infiltration into soakwells and soakage basins to be the full theoretical value, an adequate separation to groundwater must be achieved, because otherwise performance is hindered by inadequate separation to groundwater or partial submergence of the infiltrative element.

We recommend a minimum separation of 500 mm from the underside of infiltrative elements to maximum groundwater level.

- To average annual maximum groundwater level (AAMGL), where this has been defined for the site; or
- To historical maximum groundwater level, where this has been defined to the site.

GDR13.3 Design Hydraulic Conductivity Values

Where provided, the values of hydraulic conductivity (k) should be considered the maximum/upper limit design values. As discussed in Section GDR3.7, the inverse auger hole test is an unsaturated field test carried out above the groundwater table and, as such, presents the best-case conditions for drainage.

For soak wells in sand, we provide the design value taking into consideration the variability in materials and reduced permeability as a result of:

- Densification of sand during site preparation works; and
- Natural variation in sands.

Design k_{unsat} values provided for soak wells are only appropriate for the design of unsaturated soils where the base of disposal area is at least 500 mm above groundwater and 500 mm above any impermeable layer.

Where design values of k_{unsat} have been provided, clogging of the base of the soakwell / drainage basin has not been considered. Clogging will need to be controlled with maintenance over the life of the soakwell / drainage basin.

For the design of subsoil drains or modelling of saturated soil performance, a k_{sat} value must be given (in the report text or assessed by laboratory testing (or a combination of field and laboratory testing)). Unless specifically stated, k_{unsat} values presented in our report are for unsaturated conditions and intended for design of stormwater disposal elements above groundwater. If no k_{sat} value has been provided, do not use the provided k_{unsat} value for saturated drainage design. Please contact us for further advice.

For saturated or semi-saturated sands, the hydraulic conductivity must be assessed by testing of representative soil samples at a NATA accredited laboratory to determine:

- The modified maximum dry density (MMDD); and

- The constant-head permeability (AS1289.6.7.1) on a sample remoulded to at least 5% greater than the proposed specification density (i.e., sample should be remoulded to 100% MMDD if the earthworks specification requires a density ratio of 95% MMDD).

For saturated or semi-saturated clayey or silty soils, the hydraulic conductivity must be assessed by testing of representative soil samples at a NATA accredited laboratory to determine:

- The standard maximum dry density (SMDD); and
- The falling-head permeability (AS1289.6.7.2) on a sample remoulded to at least 3% greater than the proposed specification density (i.e., sample should be remoulded to 101% SMDD if the earthworks specification requires a density ratio of 98% SMDD).

GDR13.4 Soakwells

In uncontrolled groundwater environments, the base of any soakwell must be the higher of:

- At least 500 mm above the average annual maximum groundwater level (AAMGL).
- At least 500 mm above any low permeability/impermeable layers (clay, rock or otherwise).

In controlled groundwater environments (refer to Section GDR13.1), the base of any soakwell may be 0 mm above the controlled groundwater level at the location of the soakwell (as determined by the civil engineer).

Soak wells must be placed outside a line of 1V:2H extending below the edge of the nearest footing, subject to local council regulations. Discharge from soak wells has been known to promote densification of loose sandy soils, leading to settlements of footings and slabs. Soak wells should be carefully wrapped with geotextile to prevent migration of sand and fines into the soak well.

Where soak wells are proposed to dispose of water within a line of 1V:2H from any basement walls or similar, the walls must be waterproofed to prevent seepage or damp within the basement wall.

In potentially karstic terrain or areas of potentially collapsible soils, soakwells should typically be located 10 m from the nearest footing, slab or pavement.

GDR13.5 Design Groundwater Elevation

Where applicable, a recommended design groundwater elevation will be provided in the report and will be identified as such.

In the absence of a specific statement on design groundwater elevation, **do not assume** that:

- Absence of comments about groundwater indicates an absence of groundwater (in particular, sites that are dry in the dry season to the investigated depth may well become waterlogged in the rainy season).
- Where groundwater depths/levels are noted, that these are fixed (groundwater fluctuations occur over the course of the year and between wetter and drier years).

Where groundwater elevations are likely to be critical for a development (particularly where large-scale subdivision or large developments are proposed with substantial channelling of stormwater into on-site disposal by infiltration), a site-specific hydrology study is likely to be required to confirm design groundwater elevations.

GDR14. DRAINAGE CONTROL

In addition to the site preparation measures outlined for cohesive soils (refer Section GDR6.2.4), careful control of surface water and stormwater is essential to minimise the likelihood of cohesive soils decreasing in strength and affecting the installed infrastructure. These measures include:

- The ground surface of clayey soils should be graded to drain any seepage away from structures and prevent standing water over the cohesive soils. A grade of at least 1% is recommended.
- Pavements should be sealed to minimise water ingress.
- Stormwater disposal swales should be located at least 10 m away from buildings, retaining walls and pavements.
- Runoff from hardstandings and pavements must either be collected and discharged via pipes into discrete locations (via swales or soakage basins) at least 10 m away from structures and pavements or, alternatively, discharged over a wide area, but not allowed to collect and discharge into concentrated areas, particularly near structures and pavements.
- Spoon drains should be used to collect water at the crest of slopes to capture surface runoff and direct it away from running directly down slopes or seeping into the ground behind slopes.

These measures are general in nature only and do not take into account the civil design objectives, which must be addressed separately by the civil designer.

GDR15. DEWATERING

Dewatering may be required for excavations and construction below groundwater or perched groundwater tables. Common dewatering methods are summarised below:

Table GDR 19: Dewatering Recommendations

Material	Recommended Methods
Sandy Soils	Spears Deep Well Point
Impermeable Clay	Sump Pumping

Dewatering spears are typically suitable for small scale excavations below groundwater, with a typical recommendation for spears to be installed at 1 m below the base of any excavation. Dewatering spears may not be suitable where there are impermeable/cemented/strong transition layers, i.e., it may not be possible to extract water near an impermeable layer (rock/clay), or the spear may not be readily driven through a hard clay/cemented layer (i.e., coffee rock).

Sump pumping can be done by grading a clayey excavation to drain (i.e., by using spoon drains), and excavating a sump in the excavation. A sump can typically be backfilled with a blue metal gravel, with a pump wrapped in a geofabric (i.e., Bidim A14 or similar), with disposal of water away from the excavation.

Deep well point dewatering is typically suitable for larger excavations, where there are transitional layers or where the aquifer is confined. It may not be suitable where there are impermeable layers within the profile. It involves the installation of a deep filtered well to a depth required to draw down the groundwater level at the entire site. A deep well dewatering system must be designed by a suitable designer to provide design flow rates, draw down depths etc.

GDR16. PAVEMENT SUBGRADES

Unless otherwise specified, the provided subgrade California bearing ratio (CBR) is not a pavement design, but an assessment of the subgrade as an input into any required pavement designs.

Provided design values are based on the assumption that the relevant site preparation measures are completed for all pavement subgrades, including the use of appropriate approved fill and adequate compaction. We highlight that specific requirements such as those outlined by Main Roads WA (MRWA) or the local council in their construction specifications may have different requirements.

The provided design value is based on laboratory testing (where done), local experience, and the advice as outlined in:

- Main Roads Western Australia (2013). "Engineering Road Note 9 – Procedure for the Design of Road Pavements". Western Australia Supplement to the Austroads Guide to Pavement Technology Part 2: Pavement Structural Design, East Perth.

Where the subgrade differs from that described in the text, the subgrade CBR must be confirmed.

The performance of any pavement is highly dependent on the surface and subsurface drainage provided (also considering factors like capillary rise from seasonally high groundwater tables). Adequate drainage must be provided to any pavements, and capillary rise must be considered by the designer.

GDR17. SOIL CORROSIVITY AND AGGRESSIVITY

The relevant exposure classifications for concrete and steel piles in soils based on the exposure conditions are presented in Table GDR 20 and Table GDR 21 respectively.

The relevant exposure classifications for concrete in sulfate soils based on the exposure conditions are presented in Table GDR 22.

Table GDR 20: Exposure Classification for Concrete Piles in Soil

Exposure Conditions				Exposure Classification	
Sulfates (expressed as SO ₄) ¹				Soil Conditions A ²	Soil Conditions B ³
In Soil (ppm)	In Groundwater (ppm)	pH	Chlorides in Groundwater (ppm)		
< 5,000	< 1,000	> 5.5	<6000	Mild	Non-aggressive
5,000 – 10,000	1,000 – 3,000	4.5 – 5.5	6,000-12,000	Moderate	Mild
10,000 – 20,000	3,000 – 10,000	4 – 4.5	12,000-30,000	Severe	Moderate
> 20,000	> 10,000	< 4	>30,000	Very Severe	Severe

- NOTES:**
1. Approximately 100 ppm SO₄ = 80 ppm SO₃
 2. Soil Conditions A – high permeability soils (e.g. sands and gravels) which are in groundwater
 3. Soil Conditions B – low permeability soils (e.g. silts and clays) or all soils above groundwater
 4. Table reproduced from Table 6.4.2(C) of AS2159-2009

Table GDR 21: Exposure Classification for Steel Piles in Soil

pH	Chlorides		Resistivity (ohm.cm)	Exposure Classification	
	In Soil (ppm)	In Water (ppm)		Soil Conditions A ²	Soil Conditions B ³
> 5	< 5,000	< 1,000	> 5,000	Non-aggressive	Non-aggressive
4–5	5,000–20,000	1,000–10,000	2,000 – 5,000	Mildly aggressive	Non-aggressive
3–4	20,000–50,000	10,000–20,000	1,000 – 2,000	Moderately aggressive	Mildly aggressive
< 3	> 50,000	> 20,000	< 1,000	Severely aggressive	Moderately aggressive

- NOTES:**
- 1 ppm (parts per million) is equivalent to 1 mg/kg
 - Soil Conditions A – high permeability soils (e.g. sands and gravels) which are in groundwater
 - Soil Conditions B – low permeability soils (e.g. silts and clays) or all soils above groundwater
 - Table reproduced from Table 6.5.2(C) of AS2159-2009

Table GDR 22: Exposure Classification for Concrete in Sulfate Soils

Exposure Conditions			Exposure Classification	
Sulfates (expressed as SO ₄) ¹			Soil Conditions A ²	Soil Conditions B ³
In Soil (ppm)	In Groundwater (ppm)	pH		
< 5,000	< 1,000	> 5.5	Mild	Non-aggressive
5,000 – 10,000	1,000 – 3,000	4.5 – 5.5	Moderate	Mild
10,000 – 20,000	3,000 – 10,000	4 – 4.5	Severe	Moderate
> 20,000	> 10,000	< 4	Very Severe	Severe

- NOTES:**
- Approximately 100 ppm SO₄ = 80 ppm SO₃
 - Soil Conditions A – high permeability soils (e.g. sands and gravels) which are in groundwater
 - Soil Conditions B – low permeability soils (e.g. silts and clays) or all soils above groundwater
 - For disturbed soils, the assumption of soil A conditions where accelerated corrosion is possible should be considered.
 - Table reproduced from Table 4.8.1 of AS3600-2018

GDR18. LIQUEFACTION

Soil liquefaction can occur when loose, granular, Holocene age material below the groundwater table is subjected to a seismic event (typically within 15 m of the ground surface). This can cause a loss of strength and result in vertical and lateral movements of the site surface.

Where a liquefaction analysis is carried out and outlined in the report, this has been done in accordance with consideration to the design earthquake details as presented in AS1170.4-2007:

- The hazard factor is taken from Figure 3.2 (C) and Table 3.2. The Hazard Factor (Z) for Western Australia represents the 1 in 500-year annual probability of exceedance of ground motions measured in gravity (g).

- The probability factor (k_p) is taken from Table 3.1.

Unless otherwise stated, an earthquake magnitude of 7.5 for the south-west of WA is based on research by:

- Dhu T., Sinadinovski C., Edwards M., Robinson D., Jones T., Jones A. (2004) "Earthquake Risk Assessment for Perth, Western Australia". 13th World Conference on Earthquake Engineering, Vancouver, B.C., Canada. Paper No. 2748.

GDR19. EXPECTATIONS OF THE REPORT

The following sections have been prepared to clarify what is and is not provided in your report. It is intended to inform you of what your realistic expectations of this report should be and how to manage your risks associated with the conditions on site.

Geotechnical engineering and environmental science are less exact than other engineering and scientific disciplines. We include this information to help you understand where our responsibilities begin and end. You should read and understand this information. Please contact us if you do not understand the report or this explanation. We have extensive experience in a wide variety of projects and we can help you to manage your risk.

GDR20. THIS REPORT RELATES TO PROJECT-SPECIFIC CONDITIONS

This report was developed for a unique set of project-specific conditions to meet the needs of the nominated client. It took into account the following:

- the project objectives as we understood them and as described in this report;
- the specific site mentioned in this report; and
- the current and proposed development at the site.

It should not be used for any purpose other than that indicated in the report. You should not rely on this report if any of the following conditions apply:

- the report was not written for you;
- the report was not written for the site specific to your development;
- the report was not written for your project (including a development at the correct site but other than that listed in the report); or
- the report was written before significant changes occurred at the site (such as a development or a change in ground conditions).

You should always inform us of changes in the proposed project (including minor changes) and request an assessment of their impact.

Where we are not informed of developments relevant to your report, we cannot be held responsible or liable for problems that may arise as a consequence.

Where design is to be carried out by others using information provided by us, we recommend that we be involved in the design process by being engaged for consultation with other members of the project team. Furthermore, we recommend that we be able to review work produced by other members of the project team that relies on information provided in our report.

GDR21. DATA PROVIDED BY THIRD PARTIES

Where data is provided by third parties, it will be identified as such in our reports. We necessarily rely on the completeness and accuracy of data provided by third parties in order to draw conclusions presented in our reports. We are not responsible for omissions, incomplete or inaccurate data associated with third party data, including where we have been requested to provide advice in relation to field investigation data provided by third parties.

GDR22. SOIL LOGS

Our reports often include logs of intrusive and non-intrusive investigation techniques prepared by Galt. These logs are based on our interpretation of field data and laboratory results. The logs should only be read in conjunction with the report they were issued with and should not be re-drawn for inclusion in other documents not prepared by us.

GDR23. THIRD PARTY RELIANCE

We have prepared this report for use by the client. This report must be regarded as confidential to the client and the client's professional advisors. We do not accept any responsibility for contents of this document from any party other than the nominated client. We take no responsibility for any damages suffered by a third party because of any decisions or actions they may make based on this report. Any reliance or decisions made by a third party based on this report are the responsibility of the third party and not of us.

GDR24. CHANGE IN SUBSURFACE CONDITIONS

The recommendations in this report are based on the ground conditions that existed at the time when the study was undertaken. Changes in ground conditions can occur in numerous ways including anthropogenic events (such as construction or contaminating activities on or adjacent to the site) or natural events (such as floods, groundwater fluctuations or earthquakes). We should be consulted prior to use of this report so that we can comment on its reliability. It is important to note that where ground conditions have changed, additional sampling, testing or analysis may be required to fully assess the changed conditions.

GDR25. SUBSURFACE CONDITIONS DURING CONSTRUCTION

Practical constraints mean that we cannot know every minute detail about the subsurface conditions at a particular site. We use professional judgement to form an opinion about the subsurface conditions at the site. Some variation to our evaluated conditions is likely and significant variation is possible. Accordingly, our report should not be considered as final as it is developed from professional judgement and opinion.

The most effective means of dealing with unanticipated ground conditions is to engage us for construction support. We can only finalise our recommendations by observing actual subsurface conditions encountered during construction. We cannot accept liability for a report's recommendations if we cannot observe construction.

GDR26. ENVIRONMENTAL AND GEOTECHNICAL ISSUES

Unless specifically mentioned otherwise in our report, environmental considerations are not addressed in geotechnical reports. Similarly, geotechnical issues are not addressed in environmental reports. The investigation techniques used for geotechnical investigations can differ from those used for environmental investigations. It is the client's responsibility to satisfy themselves that geotechnical and environmental considerations have been taken into account for the site.

Geotechnical advice presented in a Galt Environmental report has been provided by Galt Geotechnics under a sub-contract agreement. Similarly, environmental advice presented in a Galt Geotechnics report has been provided by Galt Environmental under a sub-contract agreement.

Unless specifically noted otherwise, no parties shall draw any inferences about the applicability of the Western Australian state government landfill levy from the contents of this document.

Galt Geotechnics Pty Ltd

ABN: 64 625 054 729

www.galtgeo.com.au

50 Edward Street

OSBORNE PARK WA 6017

T: +61 (8) 6272-0200

MEMBER SCHEDULE

ITEM	MEMBER
P1	75 x 75 x 3.0 ALUMINIUM SHS (6060-T6)
J1	127 x 50 x 4 ALUMINIUM CHANNEL (6082-T5)
FB1	152 x 63 x 8 ALUMINIUM CHANNEL (6082-T5)
FB2	200 x 90 x 10 ALUMINIUM CHANNEL (6060-T5)
CFB1/2	CURVED FLOOR BEARER
SS1	152 x 63 x 8 ALUMINIUM CHANNEL (6082-T5)
TP1*	EXISTING 90 x 90 POST TO BE REPLACED

CONSTRUCTION METHODOLOGY:

- CUT BACK VEGETATION TO SLOPE IN ACCORDANCE WITH ENVIRONMENTAL CONSULTANTS REQUIREMENTS. ROOT SYSTEMS MUST REMAIN TO LIMIT MOVEMENT IN THE UPPER SURFACE OF THE SLOPE. SEEK DIRECTION FROM THE CONSULTANT TEAM IF THERE IS ANY CONCERN WITH THE SLOPE STABILITY.
- RE-SURVEY THE SLOPE AND SUBMIT TO THE CONSULTANT TEAM.
- DEMOLISH EXISTING PAVING AT THE TOP ACCESS AND ALONG EXISTING RETAINING WALLS. DO NOT DISTURB THE EXISTING RETAINING WALL TO THE MAIN RESIDENCE. AVOID PLACING CONSTRUCTION LOADS OR STORING EQUIPMENT AT THE TOP OF THE SLOPE. IF NECESSARY A 1.5kPa CONSTRUCTION SURCHARGE CAN BE ADOPTED FOR THE WORKS.
- LOCALLY CUT BACK AND EXCAVATE BASES FOR SUREFOOT PILE SYSTEM AND SMALL CONCRETE PADS ALONG THE TOP OF THE WALKWAY FROM PLATFORM RL 13.00 DOWN TO RL 9.05.
- SUREFOOT PILES ARE TO EXTEND A MINIMUM OF 3m BELOW GROUND LEVEL. CONTRACTOR TO NOTE THERE IS LIMESTONE ROCK AT VARYING DEPTHS DOWN THE SLOPE. WHERE PILES HIT ROCK, THEY ARE TO BE EMBEDDED A MINIMUM 500mm INTO THE ROCK IN ACCORDANCE WITH MANUFACTURER'S SPECIFICATION. THE CONTRACTOR MUST ARRANGE A REPRESENTATIVE FROM SUREFOOT TO ATTEND SITE TO PROVIDE ADVICE FOR INSTALLING THE FIRST PILES AND TO PROVIDE DIRECTION WHEN PILING INTO ROCK.
- THE WALKWAY STRUCTURE AND MESH FLOORING CAN BE INSTALLED ALONG THIS UPPER LENGTH TO ALLOW GREATER ACCESS TO THE LOWER SECTION OF THE PLATFORM. MAINTAIN THE 1.5 kPa CONSTRUCTION SURCHARGE LIMIT WHILE USING THE WALKWAY FOR ACCESS.
- PREPARE BASES FOR THE REMAINING SUREFOOT PILES FOR THE LOWER SECTION OF THE ACCESS WALKWAY. LOCALLY CUT INTO SLOPE TO ALLOW FOR TERRAFORCE RETAINING WALL FOOTING. INSTALL SUREFOOT PILES AS DETAILED AND ARRANGE ENGINEERS INSPECTION PRIOR TO POUR.
- ENSURE PROTECTION OF THE SLOPE DURING THE WORKS AND PROVIDE TEMPORARY SHORING AS NECESSARY. PREVENT SAND/DEBRIS FROM BACKFILLING OVER SUREFOOT BASES.
- INSTALL REMAINING ACCESS WALKWAY STRUCTURE THROUGH TO THE PLATFORM AT RL 7.40. MAINTAIN THE 1.5 kPa CONSTRUCTION SURCHARGE LIMIT WHILE USING THE WALKWAY FOR ACCESS.
- COORDINATE CONSTRUCTION AND ROCK PROTECTION OF THE LOWER LANDING PAD AT RL 1.70.
- INSTALL REMAINING SUREFOOT PILES AND ACCESS WALKWAY STRUCTURE AS DOCUMENTED.
- ARRANGE ENGINEER'S INSPECTION TO VERIFY WORKS.
- CONSULTANT TEAM TO ADVISE ON FUTURE PLANTING TO MAINTAIN THE STABILITY OF THE UPPER SURFACE OF THE SLOPE.

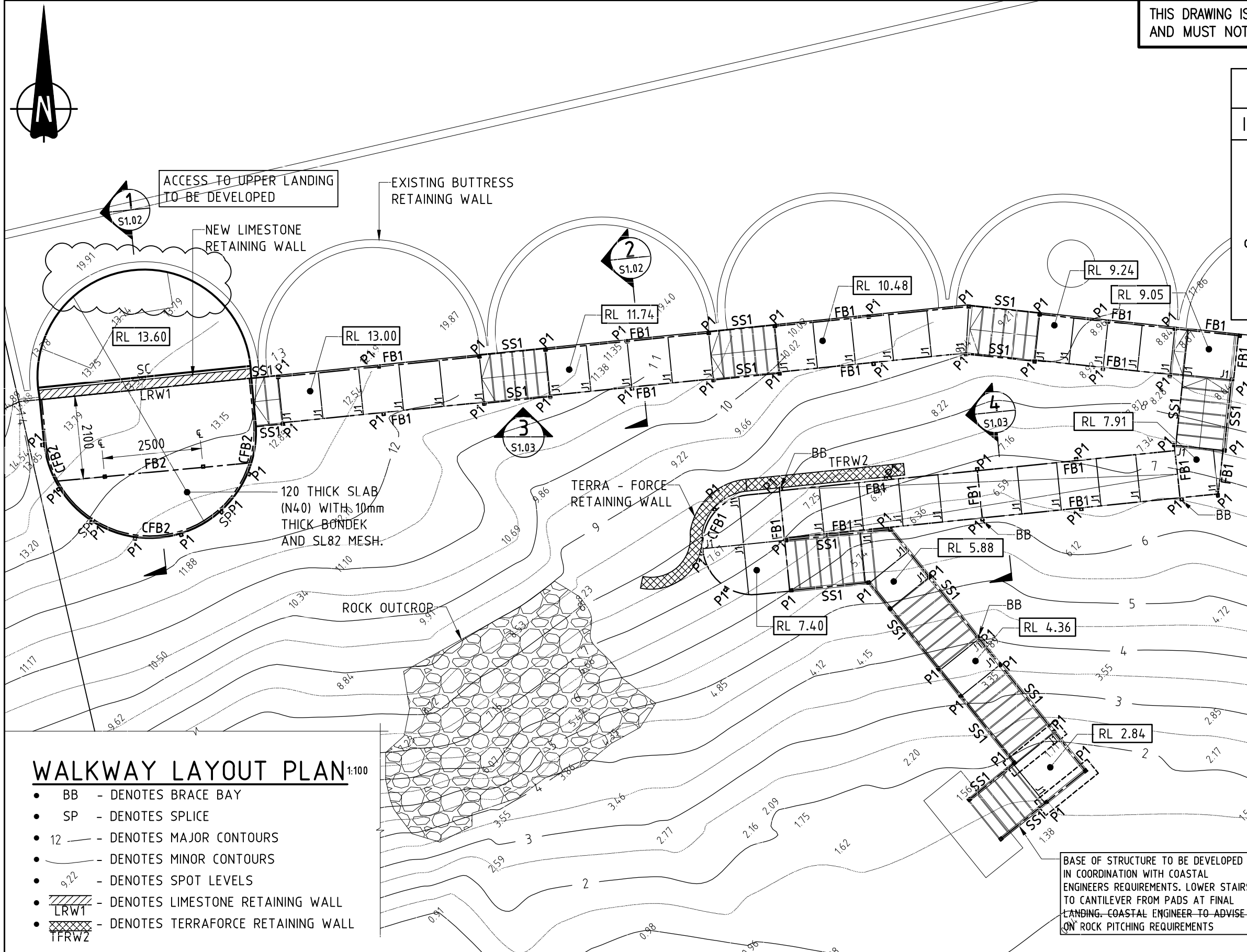

WALKWAY LAYOUT PLAN 1:100

- BB - DENOTES BRACE BAY
- SP - DENOTES SPLICE
- 12 --- DENOTES MAJOR CONTOURS
- DENOTES MINOR CONTOURS
- 9.22 - DENOTES SPOT LEVELS
- LRW1 - DENOTES LIMESTONE RETAINING WALL
- TFRW2 - DENOTES TERRAFORCE RETAINING WALL

BASE OF STRUCTURE TO BE DEVELOPED IN COORDINATION WITH COASTAL ENGINEERS REQUIREMENTS. LOWER STAIRS TO CANTILEVER FROM PADS AT FINAL LANDING. COASTAL ENGINEER TO ADVISE ON ROCK PITCHING REQUIREMENTS



ph. (08) 9389 7228 | f. (08) 9389 7221
 info@terpkos.com.au | www.terpkos.com.au
 Unit 10/18 Stirling HWY Nedlands Perth, WA 6009

REV No.	DATE	DESCRIPTION	BY	APPR.
3	26.02.24	ISSUED FOR INFORMATION	A.J.	A.J.
2	08.02.24	CONSTRUCTION METHODOLOGY ADDED	A.J.	A.J.
1	01.02.24	PRELIMINARY ISSUE	A.J.	A.J.

CLIENT:	JOSH BYRNE & ASSOCIATES
PROJECT:	FORESHORE ACCESS 26 JUTLAND PARADE, DALKEITH
TITLE:	FOOTINGS AND SLABS ON GROUND

DESIGNED:	A.J.	PROJECT No:	15069
DRAWN:	A.J.	DRAWING No:	S1.01
CHECKED:		REVISION No:	3
DATE:	JAN 2024	SCALE:	1:100
APPROVED:		CAD REF:	A.J. 15069S101.dwg 26/02/2024 11:43 AM

THIS DRAWING SHALL BE CONSIDERED FOR REFERENCE PURPOSES ONLY AND NOT FOR CONSTRUCTION UNLESS APPROVED.

THIS DRAWING IS THE PROPERTY OF TERPKOS ENGINEERING PTY LTD AND MUST NOT BE RETAINED OR COPIED WITHOUT PERMISSION.

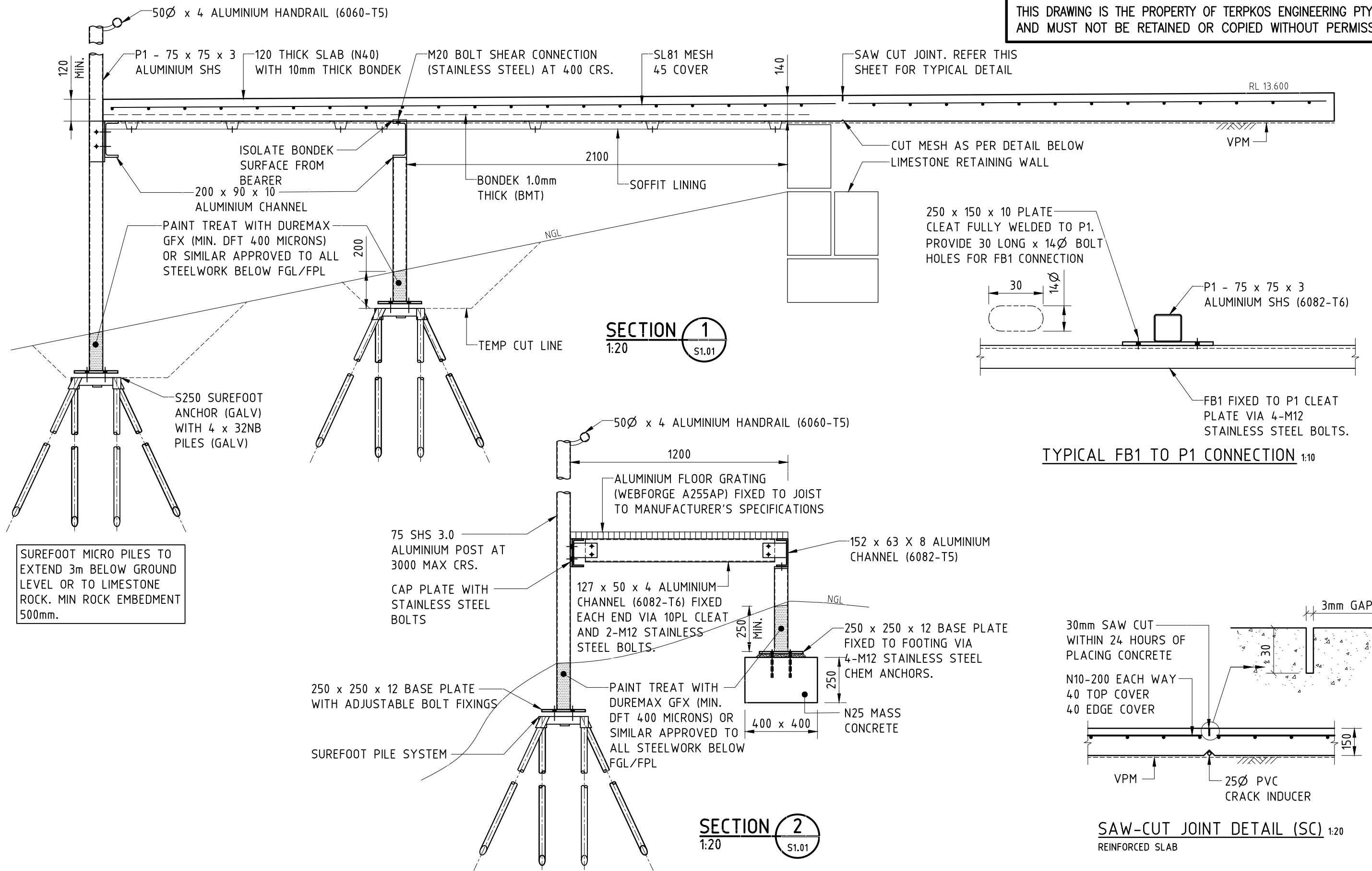

SUREFOOT MICRO PILES TO EXTEND 3m BELOW GROUND LEVEL OR TO LIMESTONE ROCK. MIN ROCK EMBEDMENT 500mm.



ph. (08) 9389 7228 | f. (08) 9389 7221
 info@terpkos.com.au | www.terpkos.com.au
 Unit 10/18 Stirling HWY Nedlands Perth, WA 6009

REV No.	DATE	DESCRIPTION	BY	APPR.
3	26.02.24	ISSUED FOR INFORMATION	A.J.	A.J.
2	08.02.24	CONSTRUCTION METHODOLOGY ADDED	A.J.	A.J.
1	01.02.24	PRELIMINARY ISSUE	A.J.	A.J.

CLIENT:	JOSH BYRNE & ASSOCIATES
PROJECT:	FORESHORE ACCESS 26 JUTLAND PARADE, DALKEITH
TITLE:	FOOTINGS AND SLABS ON GROUND

DESIGNED:	A.J.	PROJECT No:	15069
DRAWN:	A.J.	DRAWING No:	S1.02
CHECKED:		REVISION No:	3
DATE:	JAN 2024	SCALE:	1:100
APPROVED:		CAD REF:	A.J. 15069S101.dwg 26/02/2024 11:43 AM
THIS DRAWING SHALL BE CONSIDERED FOR REFERENCE PURPOSES ONLY AND NOT FOR CONSTRUCTION UNLESS APPROVED.			

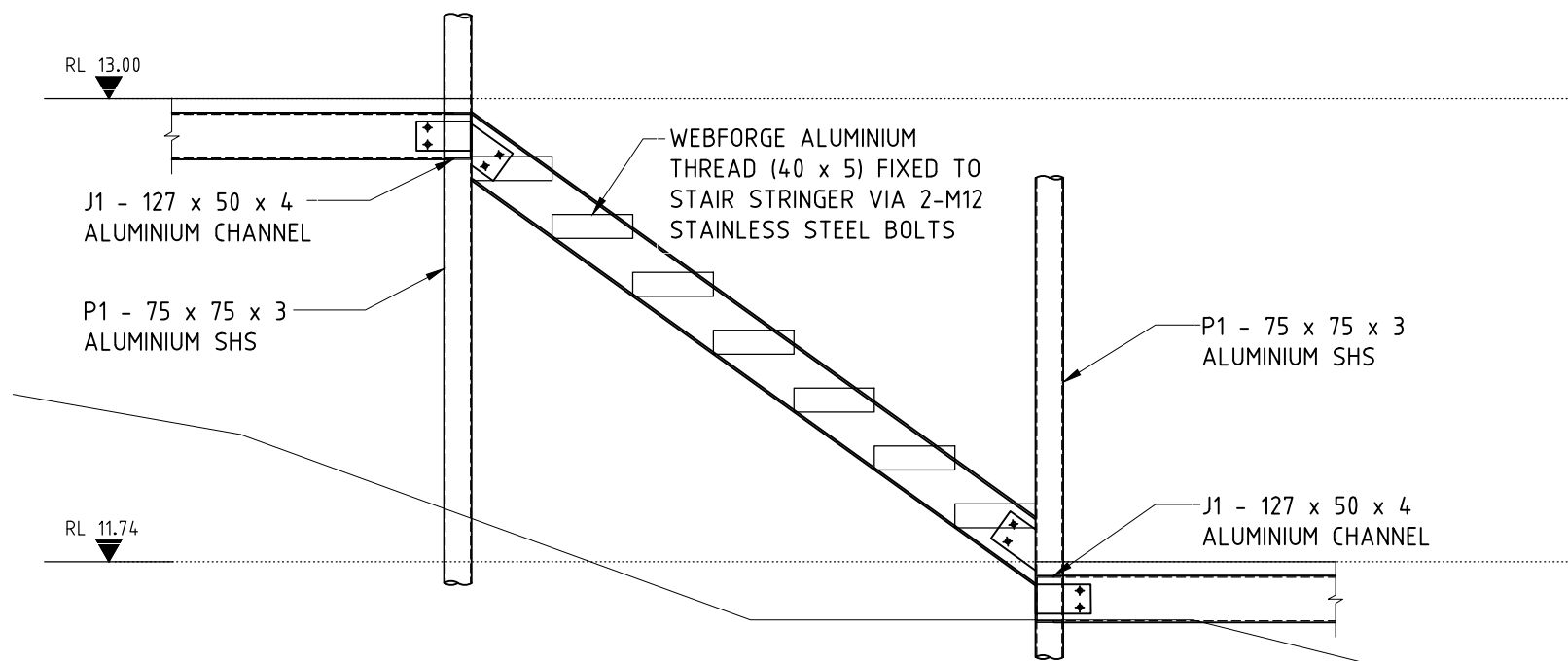

SECTION 3
1:20
S1.01

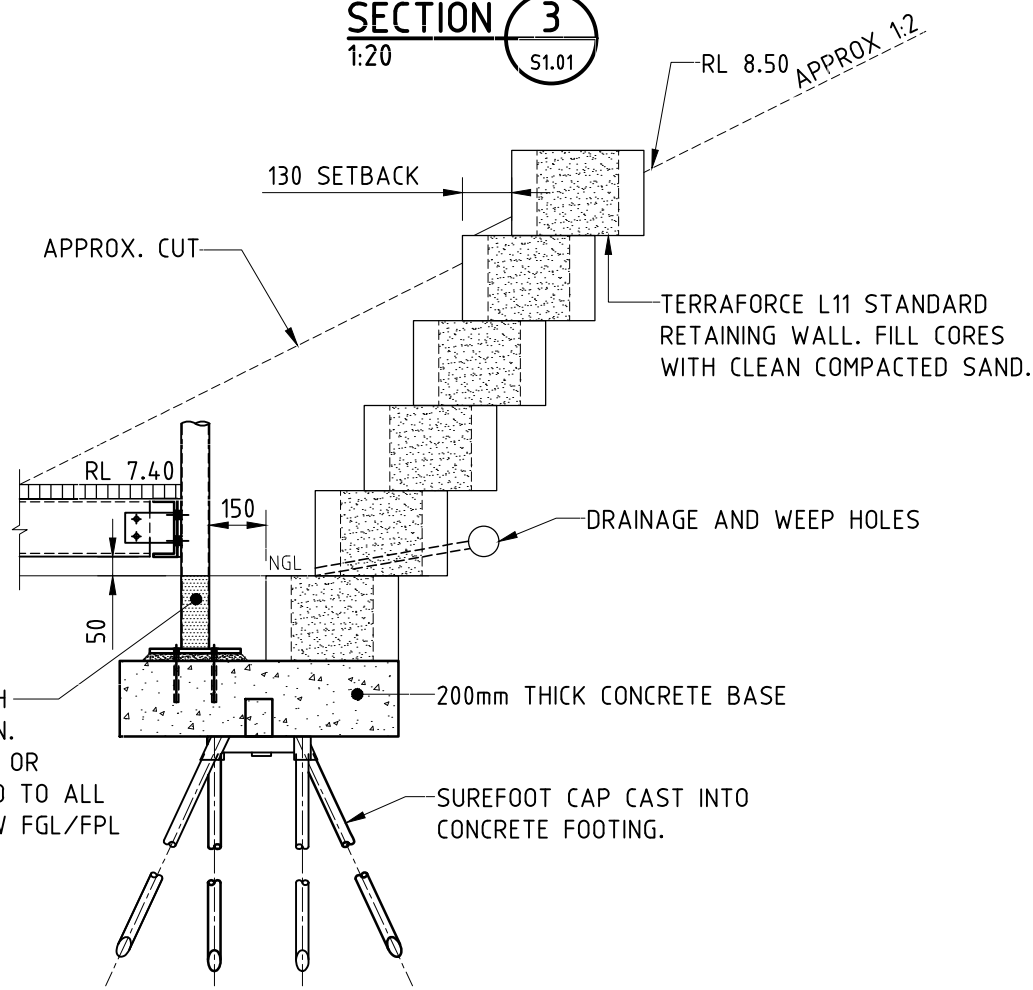

TYPICAL TERRAFORCE RETAINING WALL (TFRW2) 1:20

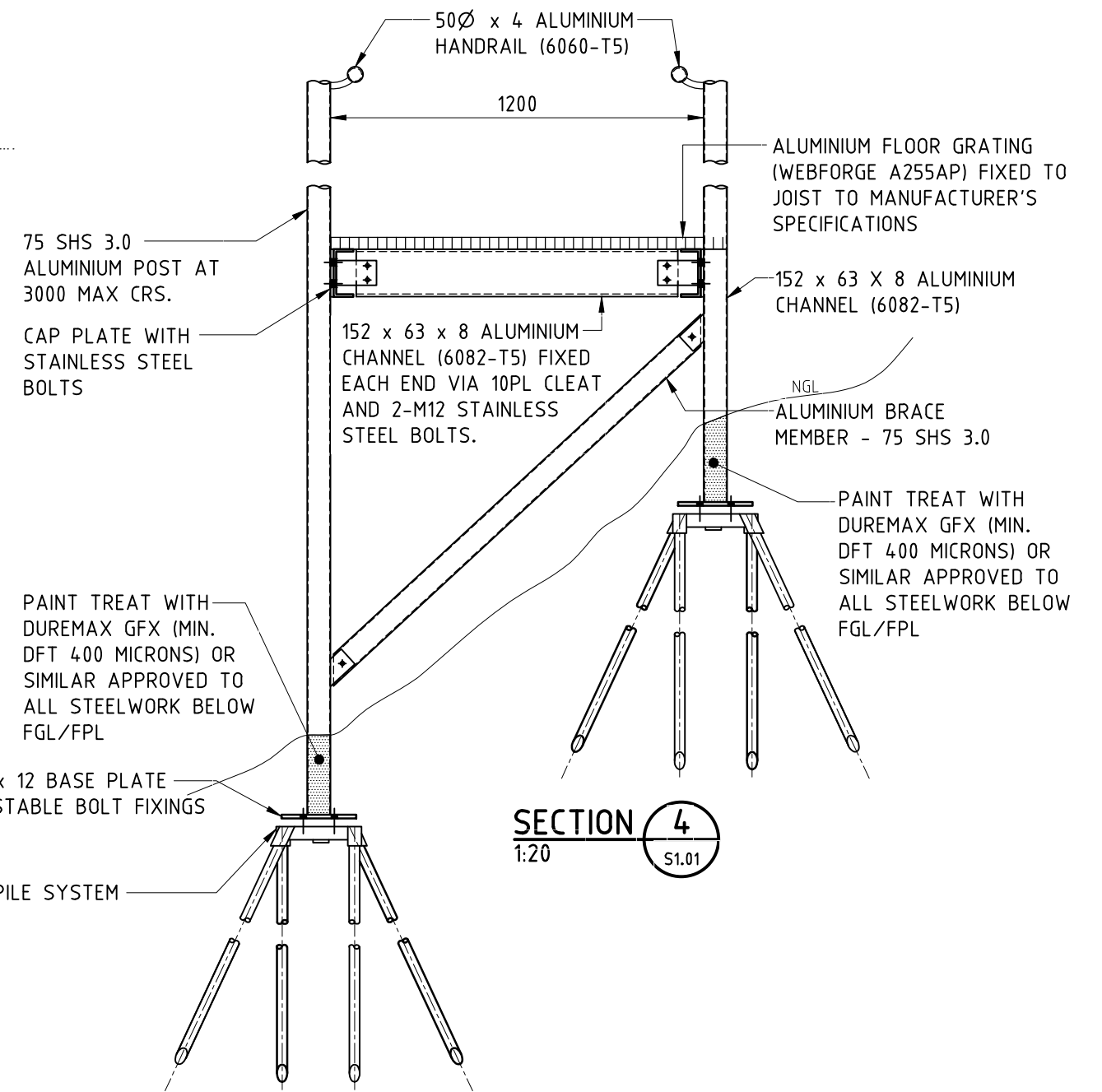

SECTION 4
1:20
S1.01



ph. (08) 9389 7228 | f. (08) 9389 7221
info@terpkos.com.au | www.terpkos.com.au
Unit 10/18 Stirling HWY Nedlands Perth, WA 6009

REV No.	DATE	DESCRIPTION	BY	APPR.
3	26.02.24	ISSUED FOR INFORMATION	A.J.	A.J.
2	08.02.24	CONSTRUCTION METHODOLOGY ADDED	A.J.	A.J.
1	01.02.24	PRELIMINARY ISSUE	A.J.	A.J.

CLIENT:	JOSH BYRNE & ASSOCIATES
PROJECT:	FORESHORE ACCESS 26 JUTLAND PARADE, DALKEITH
TITLE:	FOOTINGS AND SLABS ON GROUND

DESIGNED:	A.J.	PROJECT No:	15069
DRAWN:	A.J.	DRAWING No:	S1.03
CHECKED:		REVISION No:	3
DATE:	JAN 2024	SCALE:	1:100
APPROVED:		CAD REF:	A.J. 15069S101.dwg 26/02/2024 11:43 AM
THIS DRAWING SHALL BE CONSIDERED FOR REFERENCE PURPOSES ONLY AND NOT FOR CONSTRUCTION UNLESS APPROVED.			

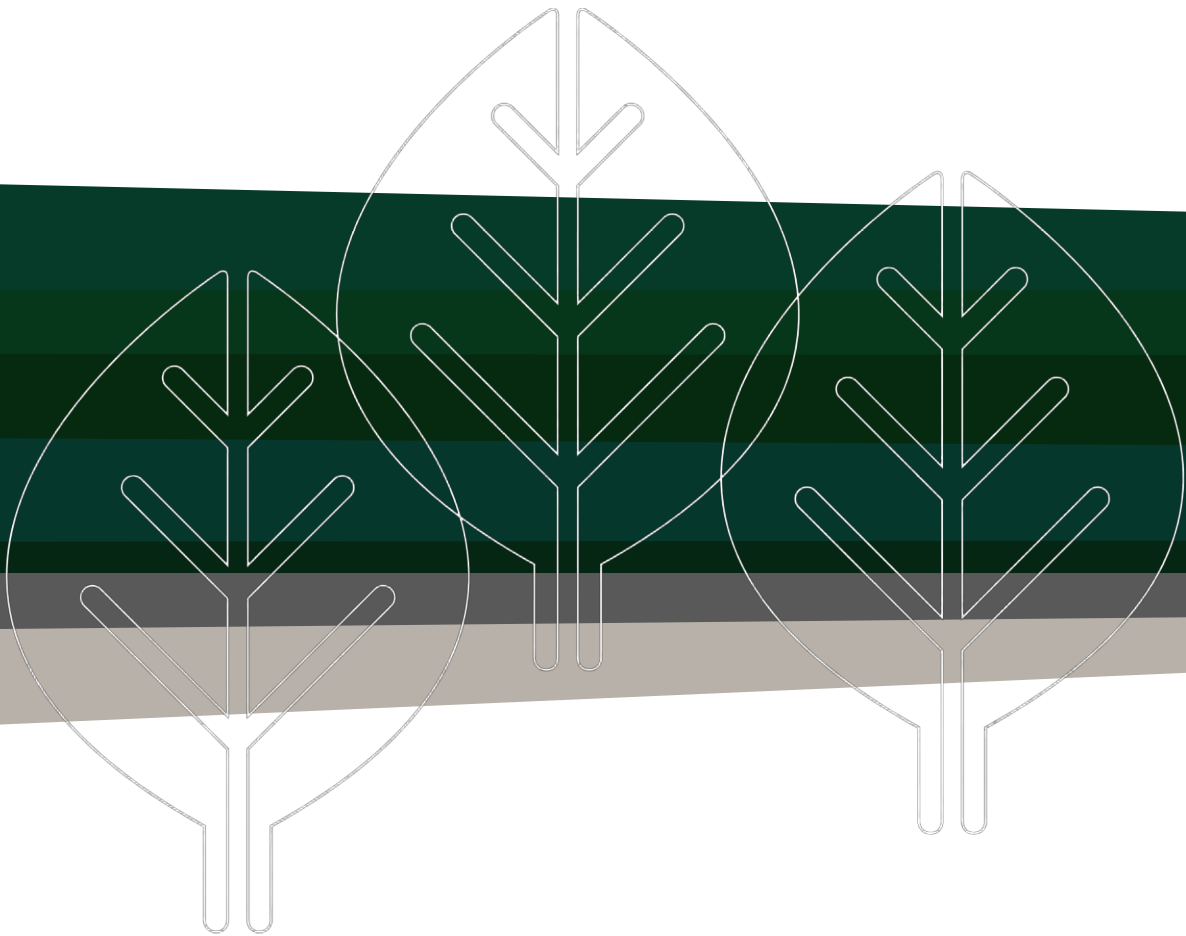

P1076A 26 Jutland Parade, Dalkeith
Revegetation Management Plan
Josh Byrne & Associates
P1076A-01-Rev0
February 2024

PERTH

11 Vincent Street
Bayswater WA 6053
p 9284 1399

SOUTHWEST

20 Possum Place
Vasse WA 6280
p 9754 2643

Disclaimer

This report has been prepared by Tranen Revegetation Systems solely for the benefit and use of the client.

Tranen Revegetation Systems shall assume no liability or responsibility to any third party arising out of use of or reliance upon this document by any third party.

This document may not be reproduced or copied in the whole or part without the express written consent of Tranen Revegetation Systems and the client.

Prepared for: Josh Byrne & Associates

Prepared by: Tranen Pty Ltd
 ABN 37 054 506 446
 11 Vincent St
 Bayswater WA 6053
 p: (08) 9284 1399
 email@tranen.com.au
 www.tranen.com.au

Document Control				
Rev	Date	Description	Author	Review
0	12/2/24	Initial report	ME	DG

Table of Contents

1	Introduction and Background	1
1.1	Background.....	1
1.2	Approvals and Conditions	1
1.3	Documentation	1
1.4	Objectives	1
2	Site Description	2
2.1	Site Location and Size.....	2
2.2	Land Tenure	2
2.3	Climate	2
2.4	Land Form and Soils	3
2.5	Site Stability	3
2.6	Vegetation Assessment	3
2.7	Existing Uses	3
3	Revegetation Strategy	5
3.1	General	5
3.1.1	Protection of Remnant Native Vegetation and Removal of Woody Weeds	5
3.1.2	Public Access and Amenities	5
3.1.3	Fencing and Site Protection	5
3.2	Slope Zone	6
3.3	Riverbank Zone.....	7
4	Implementation Methodology	8
4.1	Weed Management	8
4.2	Surface Preparation and Erosion Control.....	8
4.3	Species Selection and Plant Allocations	8
4.4	Seedling Propagation.....	9
4.5	Seedling Planting.....	9
5	Post-installation Management	10
5.1	Vegetation Monitoring and Performance Criteria.....	10
5.2	Site Maintenance	10
5.3	Completion Criteria and Success Targets	10
6	References	11
	APPENDIX 1 SITE LAYOUT	12
	APPENDIX 2 INDICATIVE SPECIES LIST	14

1 INTRODUCTION AND BACKGROUND

In February 2023 Tranen Revegetation Systems were commissioned by Josh Byrne & Associates (JBA) to prepare a Revegetation Plan for 26 Jutland Parade, Dalkeith. The property is to be redeveloped, which will require additional works on the adjoining Lot 8378 (hereby referred to as “the site”). The site is comprised of a steep, vegetated slope down to the Swan River and construction works for the project will require the removal of existing vegetation growing on the slope, followed by reinstatement of native species.

1.1 Background

The 26 Jutland Parade property is currently occupied by a large house built during the early 1970s, which included construction of the brick retaining wall along the southern boundary of the residential lot, and an access way, leading to a staircase that runs through the site down to the river foreshore. The property is to be redeveloped into a multi-storey house with two basement levels, which will require structural changes to the retaining wall, potentially impacting drainage. In addition, engineering controls are required for the slope on the site, directly below the retaining wall, to maintain structural integrity and control drainage runoff. Rebuilding of the staircase that runs from the base of the retaining wall down to the water’s edge is also planned as part of these works.

Construction works will require the removal of the vegetation currently growing on the slope, which is largely comprised of invasive species and a small number of previously planted non-native trees. Given the steep angle of the slope, this existing vegetation is likely contributing to the stability of surface soils and as such, control measures will need to be implemented during construction, followed by revegetation works to mitigate soil erosion.

1.2 Approvals and Conditions

Approval to proceed with development of the project is to be granted by the Department of Biodiversity, Conservation and Attractions (DBCA) and the City of Nedlands (the City). This plan has been prepared to fulfil a condition of the development approval.

1.3 Documentation

This report is based on the following information provided by client:

- 26 Jutland Parade, Dalkeith – Foreshore Design – Josh Byrne & Associates
- Geotechnical Study – Proposed Residential Development – 26 Jutland Parade, Dalkeith – Galt Geotechnics.

1.4 Objectives

At the time of writing the site has not yet been cleared and further studies are required once existing vegetation is removed before a detailed design of the stabilisation and revegetation measures can be provided. The objectives of this report are to create a general strategy for the successful revegetation of the site, to outline the process for installation of new vegetation, and provide details of ongoing monitoring and maintenance requirements for the life of the project.

2 SITE DESCRIPTION

2.1 Site Location and Size

The site is a rectangular lot, approximately 839 m², located along the southern boundary of 26 Jutland Parade, Dalkeith, and forms part of the Swan Canning Riverpark.



2.2 Land Tenure

The site is zoned as 'Parks and Recreation' and falls under the ownership of the City. It is also part of the Swan Canning Riverpark and is situated within the Swan River Trust's Development Control Area, the project therefore also being subject to approval by DBCA.

2.3 Climate

Climate for the area is described as Mediterranean, with warm, dry summers and cool wet winters. Summer occurs from December to February with mean maximum temperatures ranging from 30.4°C to 33.5°C. Winter occurs from June to August with mean maximum temperatures ranging from 17.9°C to 18.9°C and mean minimum temperature ranging from 8.2°C to 9.3°C. Mean annual rainfall in the area is 725.6 mm (Bureau of Meteorology, 2024).

2.4 Land Form and Soils

The site is very steep and grades from the river edge at 0 mAHD up to approximately 14.5 mAHD, with a flat section of beach at the base. The foundation of the retaining wall for the 26 Jutland Parade property starts at the top of the slope and rises to 8 m (~22.5 mAHD).

The nearby Point Resolution Reserve, Dalkeith is representative of the site's landform. The Swan and Canning Rivers Foreshore Assessment and Management Strategy's (Swan River Trust, 2008) description of the Reserve is "a short steep slope leads to coastal limestone pinnacles and emergent rocks within a beach area".

Geology series mapping contained in Fremantle Part Sheets 2033 I & 2033 IV, Perth Metropolitan Region, Environmental (Josh Byrne & Associates, 2023) indicates that the natural geology of the site comprises limestone. Visual observation also confirms indications of limestone outcropping in the setback area. The river interface of the adjacent lots also displays limestone outcroppings.

DPIRD (2019) Soil Landscape Mapping indicates the soil at the site is light yellowish brown in colour, fine to coarse-grained, and is comprised of weathered limestone, quartz, shell debris and traces of feldspar.

2.5 Site Stability

Assessment of the stability of the slope was completed by Galt Geotechnics (2023) and was considered to be "metastable", suggesting any instability would likely be a gradual creep of topsoils and limited to the top 1-2 m of the soil profile, whilst not ruling out the possibility for larger-scale slope failure occurring. A recommendation was made to dispose of stormwater towards Jutland Parade, and via soak wells situated at least 10 m away from the retaining wall. Assuming the recommendation is implemented, erosion of slope soils from offsite stormwater drainage should be minimal.

The lower ground along the southern boundary of the site is within the tidal zone and will therefore be impacted by rising water levels, along with the wave action from activity on the river.

2.6 Vegetation Assessment

The current vegetation is largely compromised of the invasive species and non-native trees which have populated, or were planted, along large sections of the riverbank. Several large Brazilian pepper trees (*Schinus terebinthifolius*) are dominating the slope, along with a variety of annual and perennial broad-leaf, grassy and other woody weeds.

The original vegetation at the site would have been part of the Karrakatta Complex – Central and South. Some large Tuart trees were observed, which are part of the Karrakatta complex and worth retaining.

2.7 Existing Uses

At present the site is mostly covered by unmaintained vegetation, predominantly comprised of non-native woody species. A degraded staircase provides access from 26 Jutland Parade

down to the water's edge. The generally poor condition of all natural and constructed features suggests usage of the areas has been minimal for a long period of time.

3 REVEGETATION STRATEGY

3.1 General

3.1.1 Protection of Remnant Native Vegetation and Removal of Woody Weeds

There is little native vegetation occurring on site with the exception of several planted eucalypts. Where possible, retention of any native species is recommended.

The large Brazilian pepper weed trees will be cut down and treated with herbicide, but the root systems may be retained initially to aid with soil stability. This will be dependent on the structural integrity of the slope and any potential damage that might be caused during removal.

Tranen can provide advice on the benefits of keeping or removing other mature trees onsite, but the final decision remains with the client.

3.1.2 Public Access and Amenities

A new floating staircase to replace the existing one will be installed from an access point in the retaining wall, down to the water, for use by the owner of 26 Jutland Parade. The site is zoned as 'Parks and Recreation' but forms part of the natural reserve of the Swan River and is not set up for public access and / or recreational use.

3.1.3 Fencing and Site Protection

Any security or safety fencing required will be arranged by the client. At this stage the only access point to this site is via the 26 Jutland Parade property.

3.2 Slope Zone



Figure 1 Looking East and Down the Slope from Access Point

The base of the slope sits at approximately 1.0 - 1.7 mAHD and rises to 13.6 mAHD at the highest point, over a distance of approximately 15 – 20 m. The western side of the top of the slope sits approximately 4 m higher than the eastern side. The slope is covered in a variety of non-native species and is divided by an old staircase down to the water.

Non-native vegetation will be strategically removed prior to planting, with root systems of some trees being left in place to help maintain slope integrity and to prevent the damage that removal would cause. Trees will be cut at the base and removed from the foreshore area by crane, as no other access options are practical. Bare areas requiring revegetation / stabilisation planting will be completed in the winter months, using native species from the list in Appendix 2. Additional erosion control measures will be implemented to assist with soil stabilisation, potentially including coir netting, coir logs, sediment fences, brush fencing, bioengineering, mulching, and retaining walls. Ongoing weed control will be required throughout the maintenance period to assist with meeting completion criteria, particularly throughout winter, spring, and summer.

The client is responsible for installing anchor points somewhere near the base of the retaining wall to allow for safe access down the slope while planting and maintaining the site. Surface preparation, specific erosion control measures and planting techniques will be devised once

the current vegetation is removed, and construction works for stabilisation are completed. Larger scale engineering controls for slope stabilisation will be designed and implemented by the client, with minor geotextile controls implemented as appropriate by Tranen, to support revegetation outcomes.

3.3 Riverbank Zone



Figure 2 Looking Up the Slope from South-east Corner

The Riverbank Zone runs from the edge of the water up to the base of the slope. Most of the vegetation is growing on the slope and overhanging this flat section of the site.

The client has engaged Seashore Engineering to assist with the design of the foreshore interface. Current designs under consideration include the installation of a rock revetment, which would be interplanted with salt-tolerant species and lined with a geotextile layer (coir netting/brush mattress or similar) to help reduce erosion. Revegetation planning will be based around the final approved civil design.

Larger-scale engineering controls for bank and shoreline stabilisation will be designed and implemented by the client, with minor geotextile controls put in place by Tranen, as appropriate, to support revegetation outcomes.

4 IMPLEMENTATION METHODOLOGY

4.1 Weed Management

The site will be maintained across a five-year post-installation completion maintenance period. Weed control events are typically completed in winter, spring, and summer each year to target the main weed species during their peak growth periods.

Herbicides will be selected for the target species, taking into account the surrounding environment and the constraints this may present. Where appropriate, selective herbicides (i.e. grass or broadleaf-specific) will be favoured over general knockdown herbicides to keep off-target damage to a minimum. In close proximity to the river, only herbicides considered safe for use in these environments will be applied (e.g. Roundup Biactive), and alternative control methods such as manual removal will be considered where appropriate.

Herbicides will only be applied by operators who:

- are appropriately qualified and licensed in herbicide application;
- have demonstrated experience in the ability to identify, and distinguish between, native and weed species; and
- are familiar with the most appropriate control measures, timing, herbicides, and application rates for the target species.

Herbicide application on this site will be constrained by access and the topography. It may not be possible to get a vehicle mounted spray unit close enough to the site. If not, backpack spraying and hand removal of weeds may be required. Weed control technicians would need to utilise the same harnesses/abseiling equipment set up for planting to navigate the slopes and will be burdened with the additional weight of either spray packs or bags containing the weeds removed by hand.

4.2 Surface Preparation and Erosion Control

Preparation may be required to assist with stabilisation of surface soils, to account for surface water runoff and to improve plant survival. The client will be arranging the installation of all rock-based stabilisation structures across the site, including the foreshore interface revetment and any additional support structures for the slope.

Supplementary stabilisation measures to support newly installed vegetation, in the form of brush mattress, coir netting and coir logs may be required. Provision will be made for adjustments or additions to these controls as necessary. Mulch is also an option to assist with surface soil stability and improve soil water retention and nutrient availability for plants.

These surface preparation measures, and any additional options, can be discussed once the vegetation has been removed and better understanding of the site stability is gained.

4.3 Species Selection and Plant Allocations

A nominal species list for this project, focusing on the Karrakatta Complex – Central and South as the main point of reference, has been devised by JBA and is provided in Appendix 2. Fast growing species that provide cover and soil stability will be preferred. Slopes create much

less favourable conditions for plant survival and as such the final species list and planting densities will be reflective of these conditions.

4.4 Seedling Propagation

Seedlings will be planted as tubestock, a broad term that relates to a variety of pot shapes, sizes, and types. In this instance tubestock will be supplied in either forestry tubes or deep cells. Although these are larger tubestock sizes, these pot types create hardier seedlings with well-developed root systems through the use of root trainers and air pruning.

Most native nurseries now operate on a forward order only basis and require plant orders to be placed before September of the year prior to the winter of installation. Seedlings should be ordered well in advance to ensure that suitable stock is available at the required time of planting.

4.5 Seedling Planting

Given the steep angle, planting will likely need to be completed by abseiling down the slope with a kidney bucket and hand trowel, and therefore anchor points will need to be installed by the client in / on sturdy structures, across the entire length of the slope. Further details of the requirements of the planting methods and anchor points can be determined once clearing has been completed and the site can be re-assessed.

It is expected that the planting will be undertaken over the naturally wet months of the year and provided the soil is moist no other watering is considered necessary. However, irrigation will be set up across the slope to optimise survival and establishment rates.

The organic matter that forms the upper most layer of the soil profile in many natural environments is often reduced or not present on slopes as organic materials often move down gradient, therefore not distributing evenly across the surface and not providing nutrients to all plants. Tranen therefore recommend the use of fertiliser tablets when planting on slopes to help compensate for some of the nutrient shortfall. Tablets are preferred over granules as they provide the nutrients directly to the target seedlings and are less accessible to nearby weeds.

5 POST-INSTALLATION MANAGEMENT

5.1 Vegetation Monitoring and Performance Criteria

Two informal monitoring events are recommended to be undertaken each year during the key growth periods of spring and autumn, for the duration of the management period, to provide data on the progress of revegetation works towards set targets. The results of the monitoring and general observations will determine whether remedial action such as weed control and infill planting are required to meet the completion criteria.

5.2 Site Maintenance

The Site will be maintained across a five-year post-installation maintenance period to ensure that a long-term self-sustaining vegetation community is established. Routine actions such as weeding, mulching, erosion control, and plant maintenance, etc. will be undertaken during this time.

Maintenance activities will generally be in response to the formal and informal monitoring. Actions such as weed control and infill planting will be in accordance with the installation plan, unless extenuating circumstances arise. For example, if certain species are not effectively establishing on site, or the erosion control measures are insufficient, then alternatives may be sought to remedy the issues.

5.3 Completion Criteria and Success Targets

Completion criteria are to be developed and presented to DBCA and the City as part of the detailed landscape planning which will take place once the existing vegetation is removed and the underlying site conditions are better understood. Targets will focus on species richness, stem densities, native cover, erosion potential and other measures as required.

6 REFERENCES

DPIRD (2019). Soil Landscape Mapping – Best Available (DPIRD-027).

Josh Byrne & Associates (2023). 26 Jutland Parade, Dalkeith: Foreshore Design Report.

Galt Geotechnics (2023). Geotechnical Study - Proposed Residential Development – 26 Jutland Parade, Dalkeith: WAG230419-01 001 R Rev0.

Swan River Trust (2008). Swan and Canning Rivers Foreshore Assessment and Management Strategy.

Appendix 1 Site Layout

08 DESIGN RESPONSE

GENERAL ARRANGEMENT

draft for review

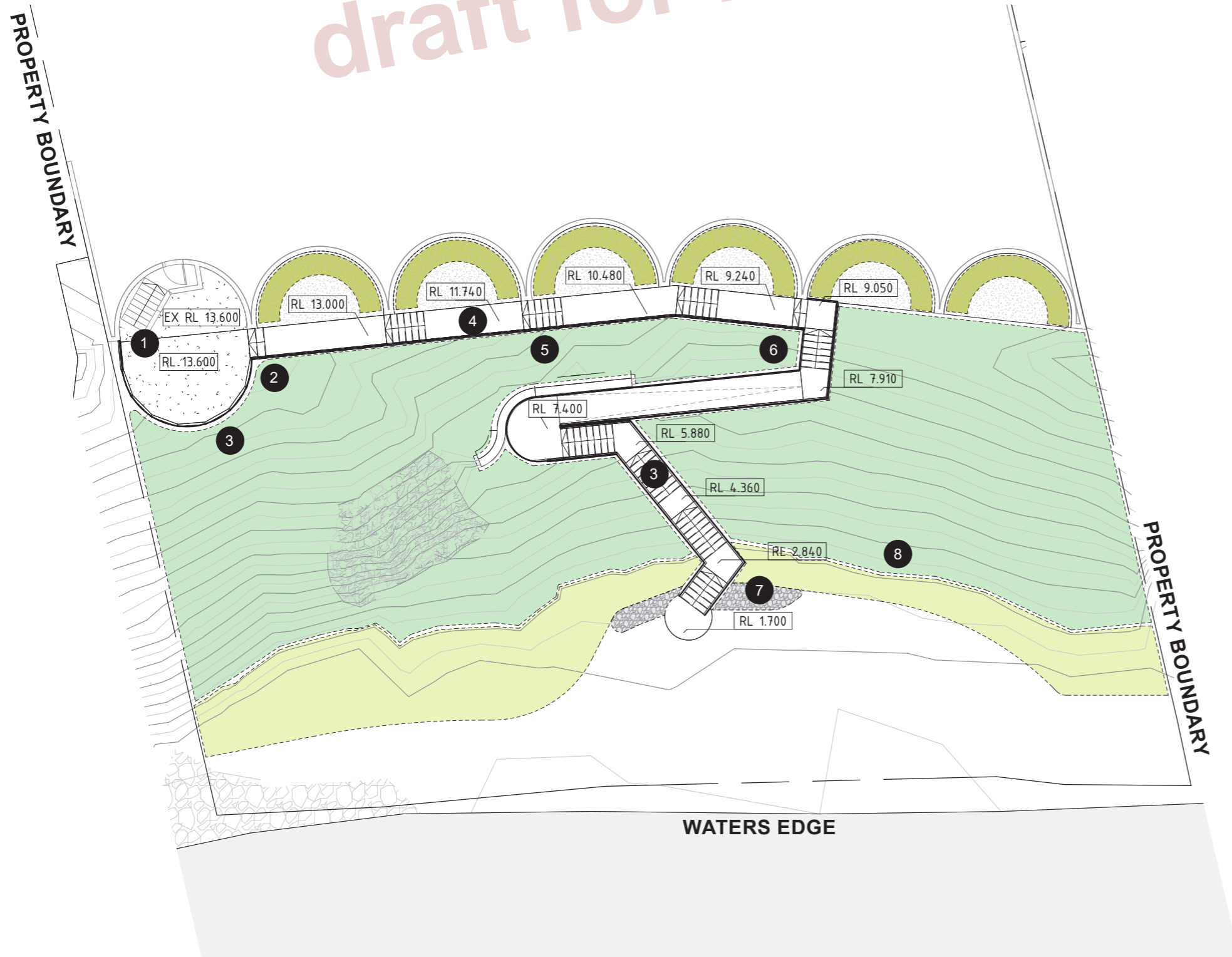

KEY

- 1 Bondek Landing to retained top landing.
- 2 "Light Touch" Aluminium Walkway Structure
- 3 Surefoot piling system.
- 4 Aluminium floor grate platform.
- 5 Stairs used to negotiate large level changes.
- 6 Balustrade.
- 7 Limestone rock revetment to back of shoreline to protect against erosion in high tides and storm surge events.

Approximate top of revetment is proposed to be between RL 1.60-1.80 AHD.

Final RL subject to coastal engineer design.

PLANTING ZONES

- Slope Revegetation
 - Native shrub and groundcover planting to embankment (Karrakatta complex species)
 - Planting mix throughout.
 - Strategic tree placements.
- Lower level planting to be salt tolerant
 - Sedges and Rushes between rocks to visually soften revetment.
 - Sedges and Rushes planted out of high water level
- Planting to rear of shoreline interface with rock revetment to improve erosion control. Appropriate bioengineering to be used to protect the planting.
- Planting zone to top of brick arches.
 - Consideration of south facing zone
 - Shade and minimal water
 - Gravel mulch

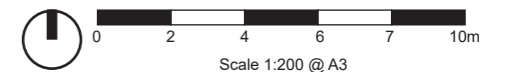

Appendix 2 Indicative Species List

12 DESIGN RESPONSE - PLANTING PALETTE

TREES

Agonis flexuosa



Image: Honkey nuts

Banksia prionotes



Image: lullfitz.com.au

Banksia menziesii



Image: Gardens online.com.au

Corymbia callophylla (Grafted)



Image: Ellenby Tree Farm

Eucalyptus gomphocephala



Image: Lucid Central

draft for review

SHRUBS AND STRAPPY PLANTS

Anigozanthos cultivars



Image: Benara Nurseries

Anigozanthos manglesii



Image: Dawsons Garden World

Alyxia buxifolia



Image: Ian Barker Gardens

Adenanthos cygnorum



Image: Honkeynuts

Banksia nivea



Image: Lullfitz

Calothamnus quadrifidus



Image: katanninglandcare.org.au

Calytrix fraseriana



Image: Pommepal.wordpress.com

Conostylis juncea



Image: nativ.com.au

Dampiera linearis



Image: nativ.com.au

Dianella revoluta



Image: gardeningwithangus.com.au

Eremophila glabra



Image: Brian Freeman

Gompholobium confertum



Image: Ita Goldberger

Hypocalymma robustum



Image: Fiona, davesgarden.com

Hibbertia hypericoides



Image: D Blumer, Botanic Parks and Gardens Authority

Orthrosanthus laxus



Image: nativ.com.au

Phyllanthus calycinus



Image: Mark Brundett

Rhagodia baccata



Image: cottesloecoastcare.org

Xanthorrhoea preissi



Image: Gary Thompson

GROUNDCOVERS

Acacia saligna (prostrate)



Image: Westgrow.com.au

Grevillea crithmifolia



Image: Plantrite

Kennedia Prostrata



Image: gardeningwithangus.com.au

RUSHES AND SEDGES

Ficinia nodosa



Image: Honkey nuts

Juncus kraussii



Image: Apace WA

Baumea juncea



Image: Benara

Species	Growth form	Optional	Recommended	Karrakatta Complex
<i>Clematis linearifolia</i>	Climber		1	
<i>Ficinia nodosa</i>	Sedge	1		
<i>Juncus krausii</i>	Sedge	1	1	
<i>Lepidosperma gladiatum</i>	Sedge		1	
<i>Acacia cochlearis</i>	Shrub		1	1
<i>Acacia cyclops</i>	Shrub		1	1
<i>Acacia pulchella</i>	Shrub		1	1
<i>Acacia rostellifera</i>	Shrub		1	1
<i>Acacia saligna (prostrate)</i>	Shrub	1		
<i>Adenanthos cygnorum</i>	Shrub	1		
<i>Allocasuarina humilis</i>	Shrub		1	1
<i>Alyxia buxifolia</i>	Shrub	1		
<i>Anigozanthos humilis</i>	Shrub			
<i>Anigozanthos manglesii</i>	Shrub	1		
<i>Bankisa nivea</i>	Shrub	1		
<i>Calothamnus quadrifidus</i>	Shrub	1	1	1
<i>Calytrix angulata</i>	Shrub	1		
<i>Calytrix fraseriana</i>	Shrub	1		
<i>Conostylis aculeata</i>	Shrub			1
<i>Conostylis juncea</i>	Shrub	1		
<i>Dampiera linearis</i>	Shrub	1		
<i>Dianella revoluta</i>	Shrub	1	1	1
<i>Eremophila glabra</i>	Shrub	1		1
<i>Grevillea crithmifolia (prostrate)</i>	Shrub	1	1	1
<i>Gompholobium confertum</i>	Shrub	1		1
<i>Hakea prostrata</i>	Shrub		1	
<i>Hardenbergia comptoniana</i>	Shrub		1	
<i>Hemiandra pungens</i>	Shrub		1	1
<i>Hypocalymma robustum</i>	Shrub	1		1
<i>Kennedia prostrata</i>	Shrub	1		1
<i>Lysiandra calycina</i>	Shrub	1		1
<i>Melaleuca huegelii</i>	Shrub		1	
<i>Melaleuca seriata</i>	Shrub		1	1
<i>Olearia axillaris</i>	Shrub		1	
<i>Orthrosanthus laxus</i>	Shrub	1		1
<i>Patersonia occidentalis</i>	Shrub		1	1
<i>Rhagodia baccata</i>	Shrub	1	1	1
<i>Scaevola crassifolia</i>	Shrub		1	
<i>Scaevola nitida</i>	Shrub		1	
<i>Spyridium globulosum</i>	Shrub		1	1
<i>Templetonia retusa</i>	Shrub		1	
<i>Agonis flexuosa</i>	Tree	1		
<i>Banksia menziesii</i>	Tree	1		1
<i>Banksia prionotes</i>	Tree	1		1
<i>Corymbia calophylla</i>	Tree		1	1
<i>Corymbia calophylla (grafted - red flowering?)</i>	Tree	1		
<i>Eucalyptus gomphocephala</i>	Tree	1	1	1
<i>Melaleuca cuticularis</i>	Tree		1	
TOTAL		26	26	24

Date: 6 March 2024

From: Matt Eliot, Seashore Engineering Pty Ltd

Introduction

This technical note provides information to support concept planning for foreshore access at 26 Jutland Parade, as part of extensive landscaping and construction of a new dwelling. Stair access has been proposed by Josh Byrne & Associates (JBA), to replace the existing dilapidated access. JBA has requested Seashore Engineering Pty Ltd to provide technical information to support the design process.

The key technical question addressed by this assessment is the potential need for stabilising works, to provide a stable base for the lowest flight of stairs.

Technical Support for DA Submission

Seashore Engineering Pty Ltd have provided technical support to JBA for the following aspects of design:

- Advice on appropriate levels for consideration of tidal inundation and wave runup.
- Review of information regarding foreshore dynamics on the site.
- Advice on appropriateness of access options.
- Advice on potential use of foreshore stabilisation works.

For further clarification of this technical note, please do not hesitate to contact me on matt.eliot@damarawa.com.

Kind regards,



Matt Eliot
Director, Seashore Engineering Pty Ltd
2/19 Wotan St Innaloo WA 6018

The existing building at 26 Jutland Parade is set back approximately 15m from the foreshore beach, with a ground level of 10-12m AHD at the building, which provides a steep descent from the building down to the shore (steeper than 1:1.5 V:H). To provide access, it has been proposed to upgrade the existing path, with a set of stairs proposed to be built.

The existing slope is heavily vegetated, with a small area of natural limestone exposed to the west of the existing path, and a scatter of small limestone spalls near the base of the existing path, possibly indicating a minor attempt to provide stabilisation. This material is spread out and could possibly have been ballast for geofabric, rather than remnants of a very small rock wall or revetment.

The bottom of the stairs has been nominated at 1.32m AHD. This is situated where the slope transitions to sand and has surface slope of approximately 1:8 V:H, down to the narrow beach 'flat' around +0.7m AHD. The landing level is above typical tide levels, but it is within the potential reach of present day severe storms, with increasing exposure from either erosion or projected sea level rise.

EXTRACTS FROM ARCHITECTUAL DRAWINGS

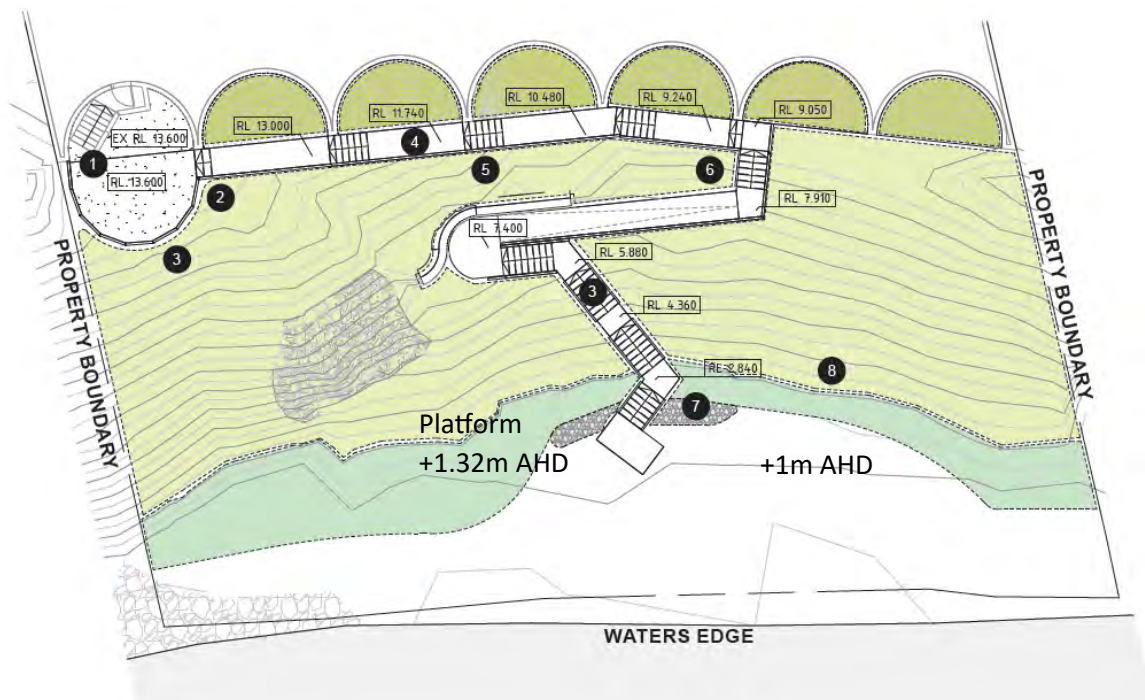

Figure 1: Extract from JBA Foreshore Design Concept

- Note: as drawn, the landing at the base of the stairs is at 1.32m AHD, with the landing extending southeast to approximately the 1.0m AHD contour. This indicates either the landing is sloped, or it will be ~0.3m above the ground, which is a large step.

Analysis of Water Levels

Water levels have been assessed through analysis of Barrack Street tide gauge data set (1988-2021). It is noted the use of tidal planes is limited in the Swan River region, as the micro-tidal conditions are dominated by non-tidal phenomena, creating strong seasonal variation, with high water levels almost exclusively within May-July and low water levels occurring from December-February. 1.65m CD (0.9m AHD) is typically reached about once per year. Please note that predicted tide is in Chart Datum (CD) which is approximately 0.76m below Australian Height Datum.

Table 1: Tidal Planes & Estimated Extreme Still Water Levels for Melville Water

Tidal Plane	Abbreviation	Level (mAHD)	Level (mCD)
Est. 100-yr Recurrence Level	100yARI	1.2 mAHD	1.95 mCD
Est. 10-yr ARI	10yARI	1.1 mAHD	1.79 mCD
Est. 1-yr ARI	1yARI	0.9 mAHD	1.65 mCD
Highest Astronomical Tide	HAT	0.5 mAHD	1.29 mCD
Mean Higher High Water	MHHW	0.3 mAHD	1.03 mCD
Mean Sea Level	MSL	0.0 mAHD	0.75 mCD
Mean Lower Low Water	MLLW	-0.3 mAHD	0.46 mCD
Lowest Astronomic Tide	LAT	-0.5 mAHD	0.30 mCD

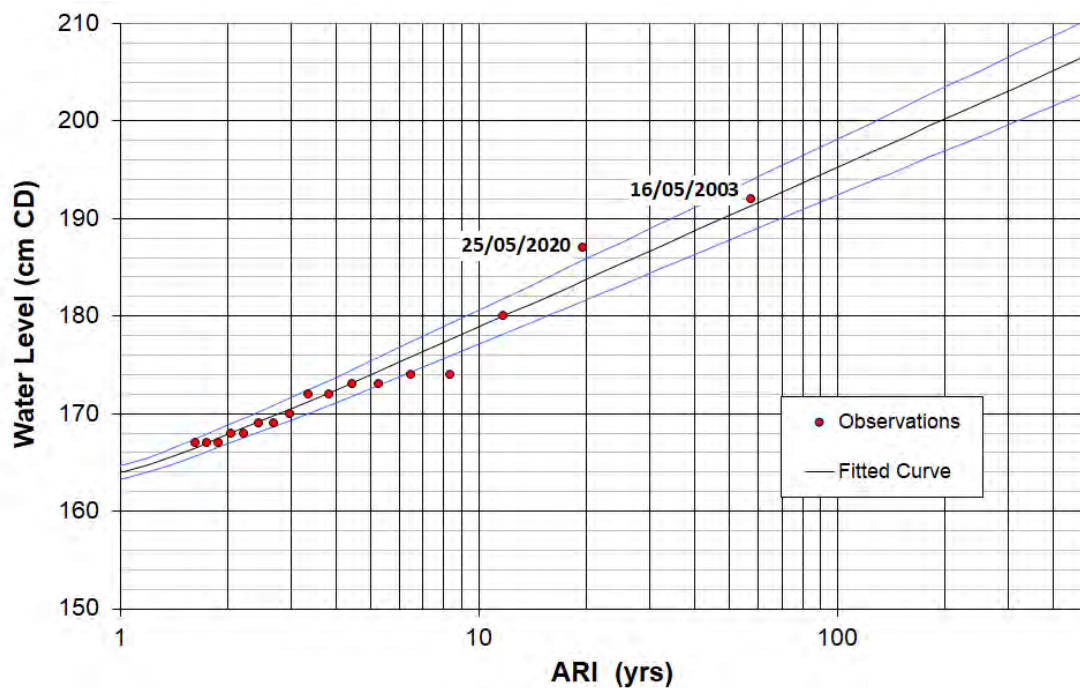

Figure 2: Barrack Street Extreme Water Levels

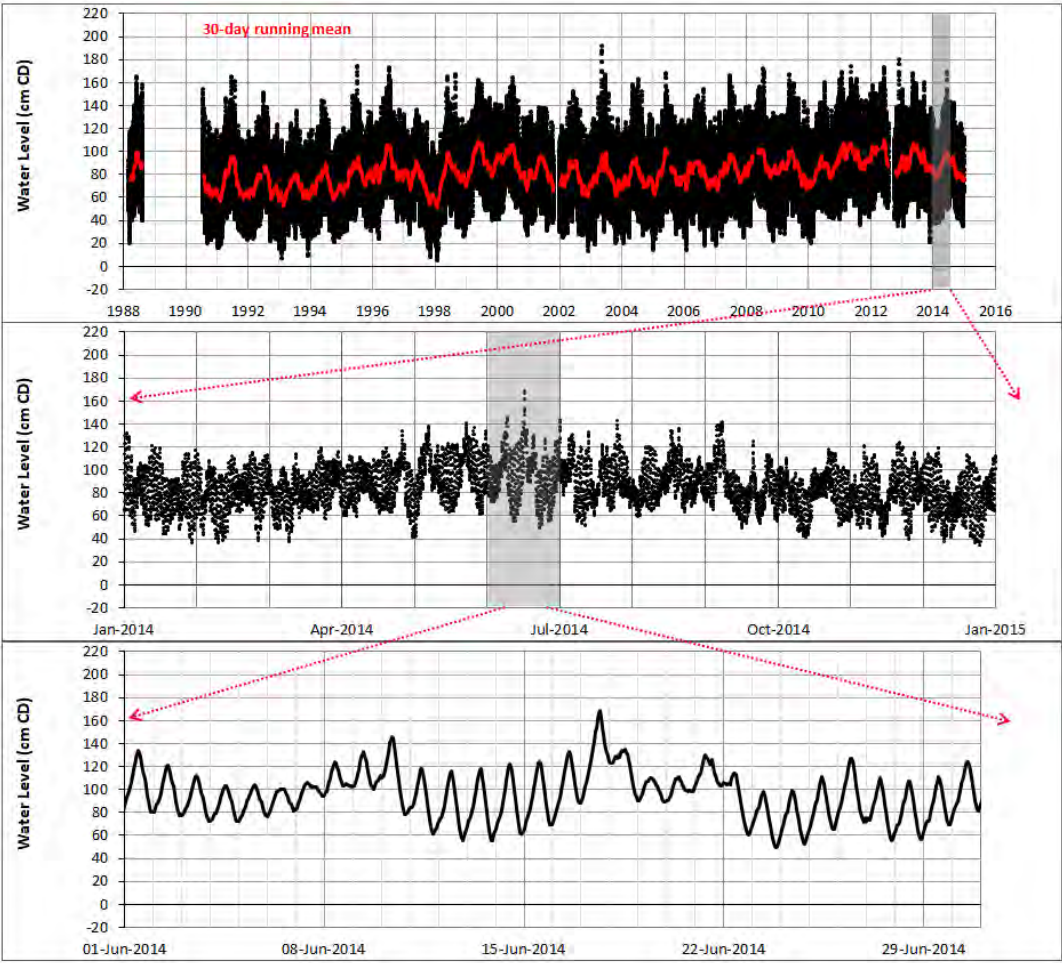

Figure 3: Barrack Street Tide Gauge Record & Illustration on Non-Tidal Dominance

Analysis of Waves

Wave conditions for the site have been estimated using the SMB wave hindcast equations, applying Swanbourne wind record (1994-2022) over available fetch lengths, identified at 10° intervals. A design wave of $H_s = 0.55m$ was selected, being 50% larger than the maximum hindcast wave. Stability of limestone armour units under wave attack was assessed using Hudson’s formula.

It is noted that due its position within Melville Water, that high waves and water levels do not typically occur simultaneously, as they are typically caused by strong winds from the east and west respectively.

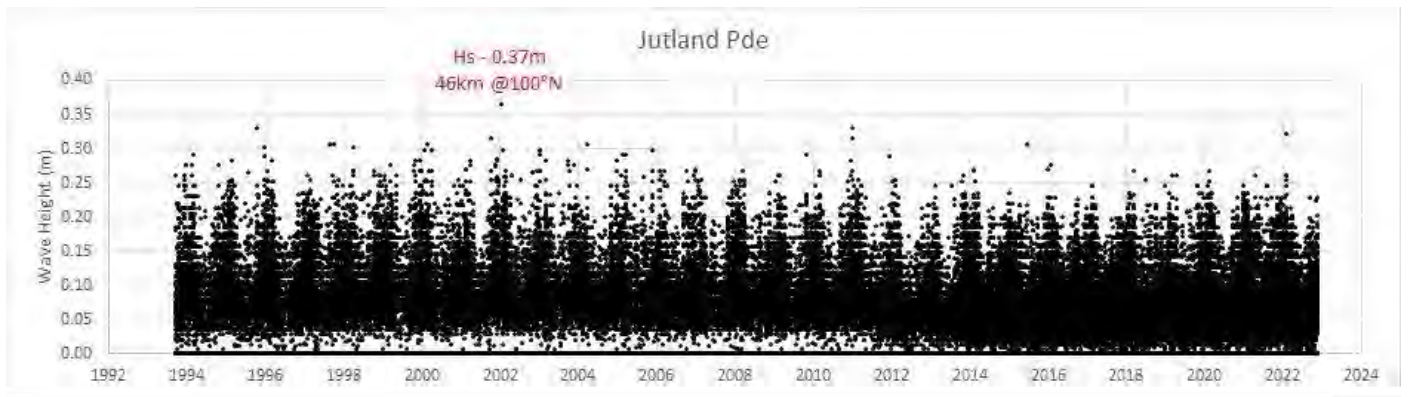

Figure 4: Wave Hindcast from Swanbourne Wind Record

Bathymetry

Estuarine basins of the lower Swan River have complex structures, resulting from interaction of river channels at lower sea levels with Tamala limestone formations, more recent dune sequences, low levels of modern (geomorphically) sedimentation, and anthropogenic modifications, including dredging, reclamation, and walling.

Jutland Parade foreshore is substantially influenced by presence of limestone, with a nearshore rock scarp extending along the whole length (Golder 2015), which has been previously subject to quarrying (Chalmers 1997). Offshore, the limestone provides a set of undular subtidal platforms, apparently a consequence of river channel meanders at lower sea level, with wider platforms near Adelma Street and at Armstrong Spit (near Tawarri). The limestone formation supports a steep underwater dropoff, with almost 50m water depth near Armstrong Spit. A veneer of sand deposits over the limestone platform has formed the modern shore, with some potential for material supply from the scarp to landward.



Figure 5: Extract from 2010 Bathymetry Image

Foreshore Change

Jutland Parade foreshore has been highly modified since European settlement, including quarrying operations. Reclamation and installation of foreshore walling occurred east of Iris Avenue in the 1970s. On the whole, aerial imagery since 1953 suggests the Jutland Parade foreshore has experienced progressive erosion (Figure 7). The narrow fringe of sand that was present along the entire shoreline in 1953 has substantially declined between 24 and 69 Jutland Parade, with loss of a thin veneer of sand exposing a largely rocky shore. Some accretion has occurred west of Iris Avenue, apparently as updrift capture due to the presence of walling pushing the shoreline riverwards further to the east.

The steep dropoff from the rock platform suggests that there is limited opportunity for sediment to be supplied from the deeper river bed, or adjacent subtidal sand masses. Consequently, potential sediment sources could include:

1. Relict sediment from quarry operations.
2. Supply from sediment resuspended by waves or currents from the wider river area. This would typically be characterised by finer sediment size (silt sized, rather than fine sand).
3. Alongshore supply from around Point Resolution.
4. Alongshore supply from the east, including Armstrong Spit or the riverbed in front of the walling. This is considered an unlikely source due to prevailing weather conditions and apparent direction of wave-driven sediment transport.

Of these potential sources, (1) is considered most likely, the presence of a 'ribbon' of sediment suggests (3) may have been historically active, and (2) is considered likely to contribute a small quantity of material.

In the immediate vicinity of 26 Jutland Parade, the beach position has retreated marginally (1-2m), with apparent partial retention of sandy material behind a rock outcrop at Adelma St, where stairs have been constructed.

Potential mechanisms for foreshore change include:

- Reduced sediment supply – likely a longer-term consequence of works stabilising the scarp (including housing & vegetation) after quarrying finished.
- Increased storage capacity at the eastern end progressively capturing the discrete volume of available sediment.
- Modified waves and water levels increasing mobility of the 'beach' sediments. This proposition is supported by the focal area of erosion extending where there is minimal width of rock platform.

Implications for future change are that the foreshore is likely to have limited recovery after disturbance events (e.g. storm erosion) and that response to projected sea level rise shall be redistribution of the existing sediment mass upward and alongshore, causing net recession.

Considering the existing beach flat as having an approximate width of 5m and an elevation of 0.7m AHD, above an approximate rock platform level around 0.0m AHD, then preservation of the same cross-sectional area would result in retreat of 2m with 0.5m sea level rise and 2.8m retreat with 0.9m sea level rise (Figure 6). In addition to this recession, erosion can also be caused by temporary beach flattening during severe wave conditions (estimated as 0.2m lowering for the 100-year wave conditions), or permanent loss due to alongshore sediment transport.

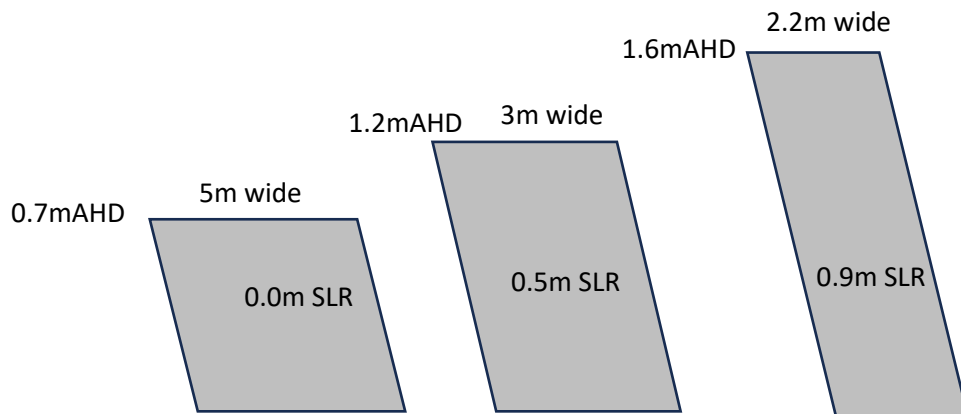

Figure 6: Notional Redistribution of Beach Wedge



Figure 7: Jutland Parade Historic Imagery 1953-2014



Figure 8: Aerial images showing local variation of erosion & accretion near 26 Jutland Parade

Scour at the Stair Base

The base landing of the stairs is proposed at 1.32m AHD. This is above direct inundation during typical annual storms but would be reached by wave action approximate 1 in 10 years, with potential for scour of approximately 0.2m vertical. The effect of scour would be enhanced if the landing causes wave reflection (e.g. a block, or walled landing). There is additional effective scour introduced by the recession caused by projected sea level rise.

Table 2: Estimate of Recession and Scour at the Landing

SLR (m)	0.0	0.1	0.2	0.3	0.4	0.5	0.6	0.7	0.8	0.9	1.0
Recession (m)	0.0	0.6	1.1	1.5	1.8	2.1	2.3	2.5	2.7	2.8	2.9
Scour * (m)	0.2	0.28	0.34	0.39	0.43	0.46	0.49	0.51	0.53	0.55	0.57

* Note that ~0.2m additional scour should be considered if there is walling.

Two significant figures are shown for clarity, but this does not indicate high certainty!

This suggests an 'easy' 0.3m step down from the landing may occur from a 0.12m sea level rise, plus a ~100 year ARI storm, or around 0.33m sea level rise with ~1 year ARI storm. Within this range, estimated horizontal recession is 0.7-1.6m, reaching to levels 1.6-1.8m AHD (i.e. not affecting the next landing up). This indicates that walling is not presently required for the landing if the lower section of stair is cantilevered.



Installing a revetment along the base of the landing would increase stability of the landing, but will also increase potential for scour. A 'severe' 0.6m step down from a walled landing could occur from 0.33m sea level rise with a ~100 year storm, or around 0.65m sea level rise with ~1 year storm. This suggests that walling or a revetment could provide functional 'intermediate' stability for the stairs for 20-50 years.

To provide a commensurate time scale for a revetment would require:

- A minimum crest elevation of +1.6m AHD.
- Stability of limestone armour units under wave attack, up to $H_s = 0.55\text{m}$. This is 50% larger than the largest hindcast wave over 1993-2022 (i.e. it approximates the $H_{1\%}$ wave condition).
- Requirement for a minimum of 3 units on the revetment crest.
- Hydraulic stability of core rock and geofabric underlayers.

Implications for Revetment Design

The maximum steepness recommended for rock slopes which are subject to wave and tidal action is 1 in 1.5 (V:H) as this represents a general practical limit, based on a balance of rock interlocking and unit mass. Steeper grades typically require grouting, providing greater effective interlocking.

The minimum rock size when using limestone armour with a minimum density of 1.9 t/m^3 is ~120kg average (50-250kg range, or 0.35-0.55m diameter). Where it is subject to tidal inundation, sizing of rock underlayer and filter cloth are crucial, as repeated tidal exchange allows sand to wash through rock armour. The recommended size for underlayer rock is 25-150mm (average 75mm) with a maximum of 15% fines.

It is recommended to construct the revetment as a multi-layer structure, with a layer of filter cloth, a 300mm thick rock underlayer, and robust non-woven filter cloth. The reliance on the filter cloth to retain sand, and range of potential loading depending on plant and rock installation determine that cloth sizing should be developed in conjunction with a work method statement.

The rock armour should extend downward to reach existing rock and be constructed with a horizontal toe of at least 2 units width. Preferably this should be constructed using rocks that are larger within the design armour ranging (typically around 250kg units) to maximise internal stability for the revetment.

The upper section of crest should be constructed with a horizontal width of 3 units (>1.0m). It may be considered by the owner of the property to construct the upper crest level of revetment to +1.8m AHD or above, which provides extreme water level (100-year recurrence) plus significant wave height runup plus 0.4m sea level rise:

$$1.2 + 0.6 * 0.37 + 0.4 = 1.8\text{m AHD}$$

Grading of the overall slope has not been designed so the revetment is a critical part of overall structural stability, which would require a higher standard of protection (100 year recurrence for a design life of 100 years). However, if required by the owner as part of overall site design (i.e. integration of revetment and building design), this could be achieved by raising the revetment crest level above +2.3m AHD.

Design of the revetment should also consider long-term potential for access to undertake maintenance. For typical excavator swing ranges of 6-8m, a lower elevation revetment may allow maintenance from the base of the revetment. This is an issue for the owner, as part of overall site design.

Material Specification

1. Levels & Slopes

Levels and slopes constructed with rock will be variable, due to rock irregularity and interlocking. These have different sensitivities for core and armour:

Core material can be measured using a 1+m straight edge, pole or plank lain on the core surface. Slopes should be within +/-5°.

Armour levels and slopes may alternately be measured from the points of contact between armour units, or an estimated level where a measurement across the rock is 80% of the rock width.

- Slopes should be within -5° to +0° (i.e. no steeper than design). The crest is designed as horizontal, but may slope upward.
- Crest levels should be -0 to +0.2m (i.e. not below the design level).

2. Rock Characteristics

Armour rock and core material shall be comprised of limestone. Armour shall have a minimum surface saturated dry density (SSDD) of individual stones of 1.9t/m³ and core shall have minimum SSDD of 1.6t/m³. A minimum of one sample rock shall be tested for SSDD and retained on site to display the appropriate rock quality providing suitable density. If material supplied displays signs of reduced density (e.g. pitting, crumbling or porosity) the Superintendent may direct additional density testing at the Contractor's expense. Material with insufficient density may be repurposed at the Superintendent's discretion or removed at the Contractor's expense.

All rock supplied by the Contractor is required to comprise of individual loads which consists of stones within the specified size range, with at least 50% of the mass of any delivered truckload being of stones greater than specified median size (i.e. >50%). No more than 5% of the material volume per truckload shall be smaller than the minimum specified size. Where visual inspection suggests inadequate rock sizing, the superintendent may direct assessment of material size to be undertaken, at the Contractor's expense.

All supplied stone shall consist of individual, hard, dense, angular, clean quarried material. Individual stones shall be sufficiently strong to maintain their integrity from the quarry to the Site and whilst being placed. Stones shall be of regular shape with the ratio of greatest to least dimension of 90% of individual stones not exceeding 3.0:1.0.

All stones shall be delivered free of adherent soil or organic matter. Delivery shall be accepted after the stones can be seen to be unbroken after delivery. Depending on the mass, shape and integrity of broken pieces of rock the Contractor may be permitted to include broken rock within a smaller rock class subject to the approval of the Superintendent.

Rock shall be supplied as armour or core classes, with each class being delivered in wholly separate loads. Each load shall be placed where agreed with or directed by the Superintendent. The Superintendent may inspect rock stockpiles at the quarry source prior to commencement of transfer of material to Site, to ensure it meets the required specification.

Structure Application	Min. Density	Mass	Median	Sizing	Median
Armour	1.9 t/m ³	50-250kg	120kg	350-550mm	450mm
Core Material	1.6 t/m ³	n/a	n/a	25 – 150mm	75mm

3. Filter Cloth Characteristics

Filter cloth required for the Works is a non-woven geotextile suitable to retain in situ soil and survive installation of core material and working to interlock rock armour. It is envisaged that typical mid-strength filter cloth can be used, such as BIDIM A34, Geofabrics Australia Texcel 600R, or Global Synthetics Profab AS600X, or alternative products demonstrating equivalent tear resistance / burst strength. However, as stresses for filter cloth will vary depending on installation processes, plant used and operator handling, an alternative filter cloth may be proposed for the Superintendent's approval, supported by a Work Method Statement developed by the Contractor.

Filter cloth sheets shall have a minimum overlap of 0.75m, and do not require stitching together.

Rock armour should not be placed directly on filter cloth, with a bedding layer installed before rock placement. The thickness of the bedding layer depends on installation and placement, with a 100mm core rock bedding layer considered adequate for robust filter cloth, if placement is undertaken to near zero drop height and limited reorientation of the base layer of armour rock.

4. Construction Sequence

Construction of the revetment adjacent to the existing foreshore walling, including shallow excavation, requires careful handling, to ensure that works do not destabilise the walling.

The proposed works are to be conducted in an intertidal area, requiring selection of appropriate plant and may correspondingly require works to be conducted during constrained tidal windows.